

扁平型電動滑台

軌道內嵌

Low Profile Electric Actuator GLTH/GLTHD/GLTHM/GLMH/GLTB/GLCH/GLCHD/GLCB Series

Height reduction, convenient for assembly.

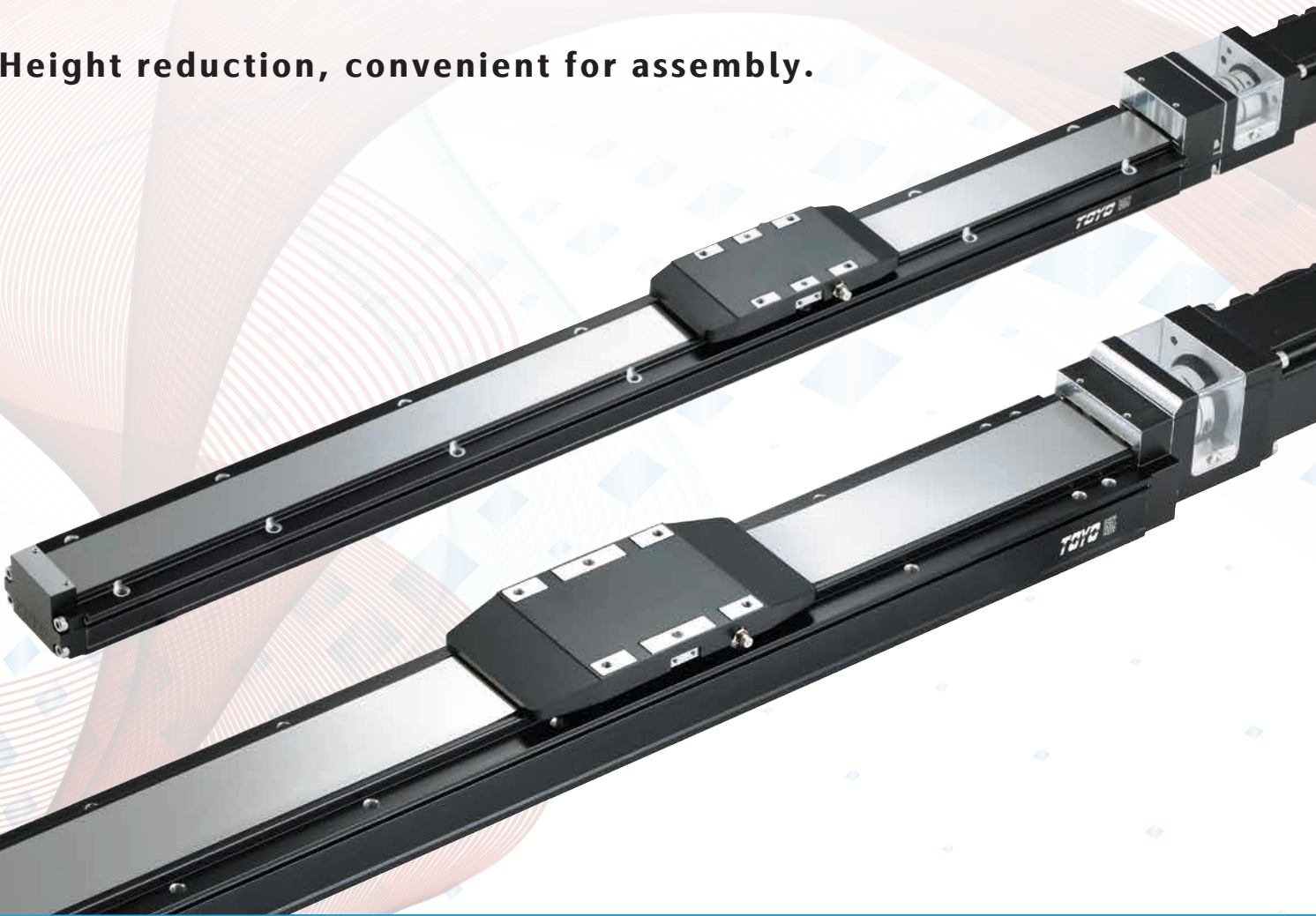

[GL系列特點]



升級再進化，揮別舊體驗！ 全新扁平型軌道內嵌式電動滑台系列



成本降低約5%~20%

本體兩側內嵌鐵芯滑軌後研磨加工，降低體積，相較市售滑軌，力矩大幅提升。

組裝高度降低，但與舊款GTH特性功能不變，本體鋁材使用量減少，降低產品重量，除低組裝優點外，更輕量、更方便，對環境也更環保節能、降低碳排。

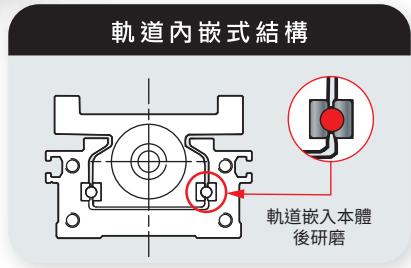

價格優勢



5~20%

GL系列相比GTH系列有顯著的成本下降優勢。採先進製造技術與材料改良，成功降低了生產成本，更具競爭力。

上、下皆可鎖

不需拆卸鋼帶，即可由上往下固定或由下往上固定。本體底部有定位PIN孔。

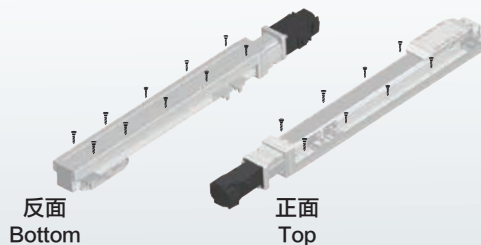

聯軸器可視化



現場設備工程師可在滑台不停機的狀況下，直接由透明外蓋觀看聯軸器有無斷裂或異常動作或聲音。節省人員拆蓋檢修時間。

扁平型

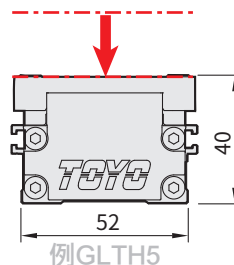

高度降低、低組裝設計
不論單軸或疊加XYZ組合皆可降低設備總體高度，實現機構小型化，客戶端廠房空間使用更寬裕。

安裝基準面

本體側面增加安裝基準面承靠，提高安裝精度。減少裝配時間。

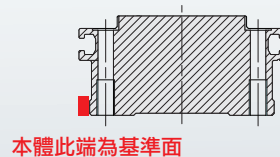

與市售相比，相同表現性能，業界高度最低。❗

重心降低，節省空間

單位:mm

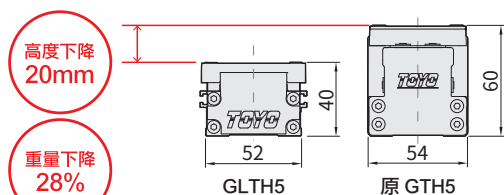

軌道內嵌設計，剛性大幅提升

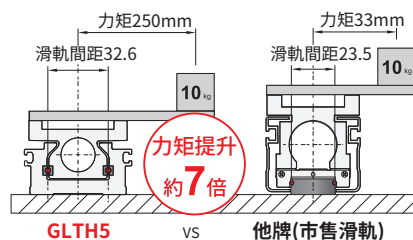

仕樣齊全

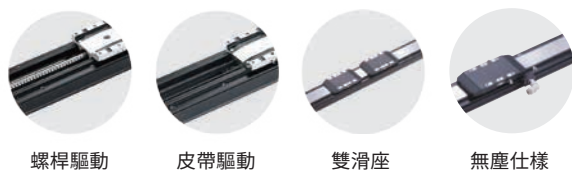

超長行程M款系列

GLTH8M
螺桿
最長行程 **2500** mm

GLTB8
皮帶
最長行程 **3000** mm



專利螺桿輔助抱持座，防止因長行程而變形下垂

馬達安裝位置

多方向馬達安裝位置可供選擇，讓機台設計更有彈性。



低發塵對應

開放款設計，標配防塵鋼帶，輕薄短小不需追加外觀包覆，即可防止異物入侵。

全密閉款設計，密閉式防塵鋼帶防塵效果佳。

無塵款設計，追加抽氣接頭，可適用於無塵環境CLASS10。



鏈帶型滾珠結構•降低噪音•增加壽命

無滾珠間碰撞與摩擦，可大幅度降低移動噪音，增長使用壽命，減少保養次數。

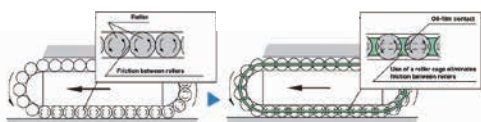

一般滾珠結構會摩擦

鏈帶滾珠結構減少摩擦

*限定GLTH8/GLTH12/GLMH8/GLMH12/GLTB8

外部集中注油保養容易

滑座2側皆有外拉注油嘴，螺桿、軌道可同時給油，方便保養。

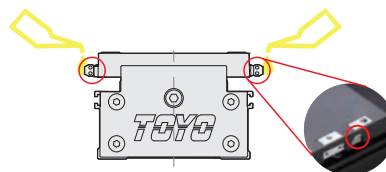

高精度

GLTH5/8

位置重複精度 | ± 0.005 mm

行走直線度/等高度 | ± 0.02 mm/800mm

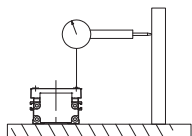

選配C5等級螺桿

可選配C5等級螺桿定位精度可達

$\pm 3\mu$ m

選配螺桿
等級
C5

染黑本體、螺桿可選配冷電鍍

本體鋁陽極黑處理，提升美觀、提高表面耐腐蝕性、耐磨性和熱穩定性，延長滑台的使用壽命。

可防止舊產品GTH系列鋁原色反光問題，適用於低光反射需求之光學檢測設備、影像判讀精密設備等應用。

螺桿可選配冷電鍍。



[GL與鐵本體滑台比較]



市面上滑台那麼多，我要選擇鐵滑台還是GL鋁滑台的呢？

鋁本體 GL Series



鐵本體



同寬幅行程選項

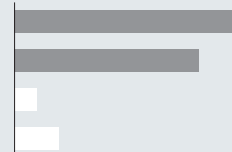

皮帶最長 3000mm
螺桿最長 2500mm



他牌①螺桿最長 300mm
他牌②螺桿最長 600mm

同尺寸本體重量



GLTH5 行程300mm 1.5 kg
減輕整體機台設備重量



他牌①行程300mm 2.4 kg
機台設備重量重

驅動方式



螺桿驅動 皮帶驅動



螺桿驅動

保養便利性

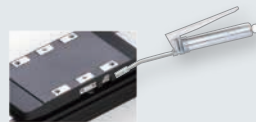

外部專利油嘴設計
螺桿軌道同時保養

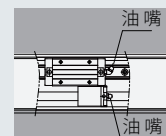

油嘴位於滑塊處
須拆上蓋才能保養

交期



< 14天
全部零件自廠生產，無需等待



> 14天
滑座、上蓋等加工件需等待

客制化彈性



可客製XYZ、龍門等連結方式



無法客製，單軸出貨



相信經過本篇的分析，大家應該知道怎麼選擇了！
總之，鐵滑台的保養、組裝都相對複雜且耗時！
GL設計圖面簡單，套入即可，組裝人員也很方便使用！



	鋁本體 GL Series	鐵本體
<p>結構</p> 	 <p>組裝調教完成 </p>	 <p>上圖藍色所示零件需自行購買組裝</p>
<p>導入快速性</p> 	 <p>上鎖/下鎖/PIN孔 </p>	 <p>只有通孔/無PIN孔</p>
<p>各種環境使用的專用規格</p> 	 <p><input checked="" type="checkbox"/> 開放型 <input checked="" type="checkbox"/> 防塵密閉 <input checked="" type="checkbox"/> 無塵室 </p>	 <p><input checked="" type="checkbox"/> 開放型 <input checked="" type="checkbox"/> 防塵密閉須加裝上蓋或防塵套</p>
<p>組裝可靠性</p> 	 <p>滑座、滑塊一體化</p>  <p>馬達固定座一體化 大幅減少組裝誤差 </p>	 <p>滑座、滑塊分開</p>  <p>馬達固定座需自行組裝法蘭 組裝精度誤差大</p>
<p>一站式購足</p> 	 <p>ALL-IN-ONE</p> <p>一次性採購 窗口單一，聯繫方便 </p>	 <p>零件眾多，多家廠商採購 窗口複雜、手續繁多</p>
<p>價格</p> 	 <p>相同性能行程價格 只要鐵本體 50%~70% </p>	 <p>相同性能行程成本較高</p>
<p>減少工時</p> 	 <p>設計/組裝/採購工時可減少為 1/2 </p>	 <p>設計耗時、組裝與調教耗時 採購詢價交貨也耗時</p>

內部結構圖-軌道內嵌式螺桿

Inner structure

Built-in linear motion guide ball screw actuator

滑座剛性強化 Improving Carriage Rigidity

鋁滑座內嵌滑軌，降低滑座重量。

The aluminum carriage incorporates embedded rails, reducing the weight of the carriage.

體積小型化、高度降低 Lower profile body

因為採用鋁本體結構，本體強度大幅增加。

結構更新後，高度更降低，寬度縮小，實現機構小型化。

Due to the adoption of an aluminum main body structure, the overall strength has significantly increased. With the structural updates, the height has been reduced, and the width has been narrowed, achieving a more compact design.

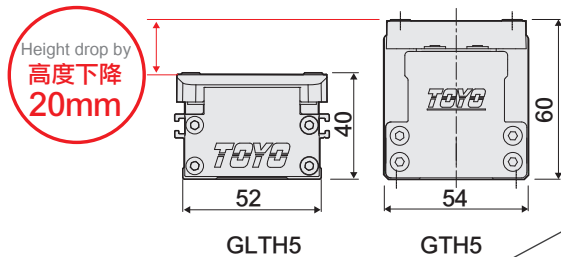

聯軸器外蓋可視化 See-through coupling window

現場設備工程師可在滑台不停機的情況下，直接由透明外蓋觀看聯軸器有無斷裂或異常動作或聲音。節省人員拆蓋子的檢修時間。

On-site equipment engineers can, without stopping the carriage, directly inspect the coupling for breakage, abnormal movements, or unusual sounds through the transparent cover. This saves time on removing the cover for maintenance.

超長行程M款系列 Ultra long stroke

GLTH8M

螺桿
最長行程 **2500** mm

GLTB8

皮帶
最長行程 **3000** mm



專利螺桿輔助抱持座，防止因長行程而變形下垂

超長行程：最長行程對應到2500mm(市售同型比，行程高3倍以上)。螺桿加長行程，專利設計抱持座，抑制螺桿高速甩動產生共振。

Ultra-long Stroke: The maximum stroke reaches up to 2500mm (over 3 times the stroke compared to similar models on the market). The lengthened ball screw stroke, combined with a patented design for the supporting, suppresses high-rpm oscillations, preventing resonance.

組裝省時、方便 Easy assembly

① 不需拆卸鋼帶，即可由上往下固定或由下往上固定。

No need to disassemble the steel strip; it can be fixed from top to bottom or from bottom to top.

② 本體側面增加安裝基準面承靠。

Mounting datum plane designed on the side of the body.

③ 本體底部有定位PIN孔。

Built in Pin holes (Options).

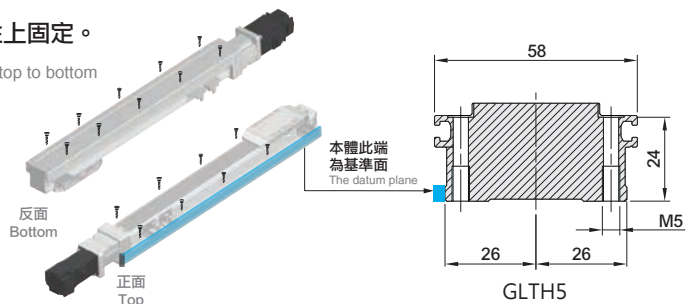

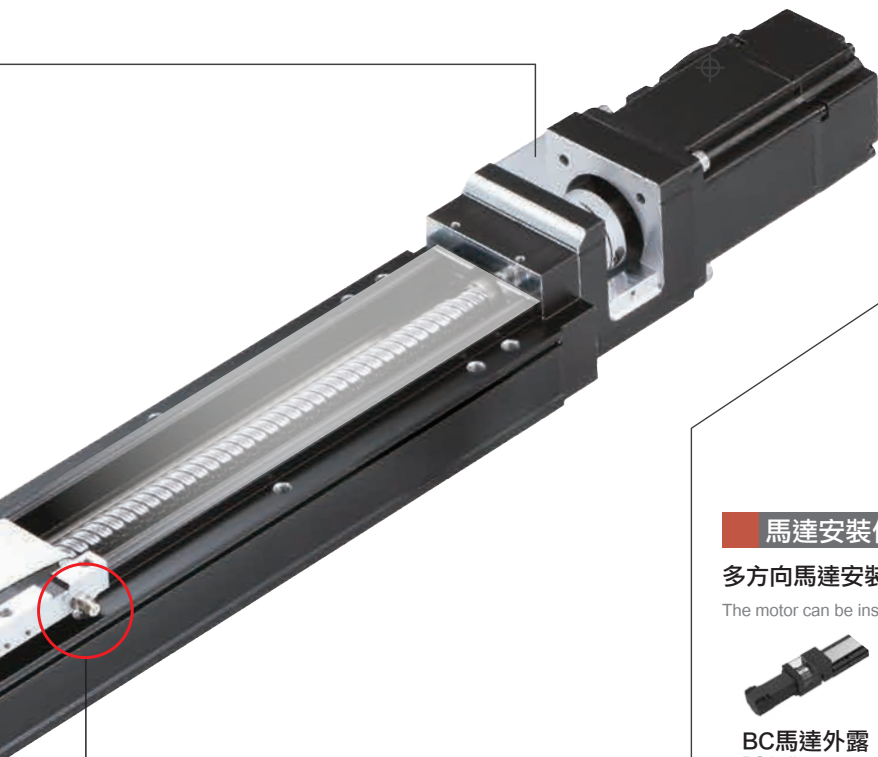

馬達廠牌 Motor brand

可搭配各廠牌的伺服馬達。

Compatible with servo motors from various brands.

馬達廠牌
Motor brand

三菱 Mitsubishi	國際 Panasonic	安川 Yaskawa	台達 Delta
------------------	-----------------	---------------	-------------

◎其他馬達廠牌規格，請聯絡業務人員。
◎ Please consult with our sales personnel for other motor specifications.

馬達安裝位置 Motor mount direction

多方向馬達安裝位置可供選擇，讓機台設計更有彈性。

The motor can be installed in multiple directions, providing flexibility in machine design.



BC馬達外露
BC in-line mount



BL馬達左折
BL Parallel mount (Left)



BR馬達右折
BL Parallel mount (Right)



BM馬達下折
BL Parallel mount (Downward)

保養簡單 Easy to maintain

全系列皆可外部注油，不須拆蓋。

External greasing design, easy maintenance without removing the cover.

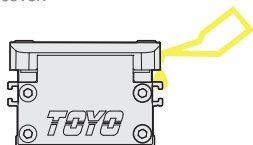

不易發塵 Reduce dust

標配防塵鋼帶：輕薄短小亦不用另外追加外觀包覆，即可防止異物入侵。

Special steel strip cover sealing design can prevent dirt and foreign objects from penetrating inside. Can be used in clean room environment.

等高直線度 Flatness and Straightness

軌道嵌入於本體後研磨，行走等高直線度可達 $\pm 0.02\text{mm}$ 。

Built in linear rail design, straightness and flatness reach up to $\pm 0.02\text{mm}$.

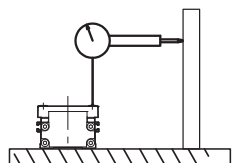

GLTH5直線度 $\pm 0.02\text{mm}$
*行走800mm時。
Straightness of GTH5 is $\pm 0.02\text{mm}$.
*Measure length is 800mm.

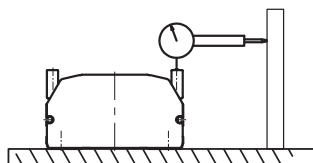

ETH10直線度 $\pm 0.05\text{mm}$
*行走1000mm時。
Straightness of ETH10 is $\pm 0.05\text{mm}$.
*Measure length is 1000mm.

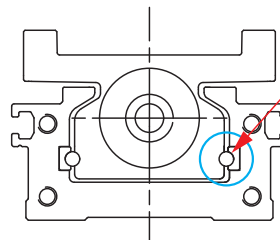

軌道內嵌
Embedded rail

滑台模組規格索引

Spec Index of Electric Actuator

GLTH/GLCH 扁平型軌道內嵌式螺桿滑台系列

GLTH/GLCH Built-in Linear Motion Guide Ball Screw Actuator-Slider Type

使用環境 Environment	傳動方式 Driven Mode	仕様 Specification	馬達容量 Motor Output (w)	本體寬幅 Width(mm)	位置重複精度 Repeatability(mm)	螺桿規格 (C7 級) Ball Screw Spec		最大可搬重量 Maximum Payload(kg)		最高速度 Maximum Speed (mm/s)
						外徑 Outer Diameter(mm)	導程 Lead(mm)	水平使用 Horizontal	垂直使用 Vertical	
一般環境 Standard	滾珠螺桿 Ball screw	GLTH3	30W	30	±0.005	6	2	13	5	120
							8	10	2	480
		GLTH5 GLCH5	100W	52	±0.005	10	2	30	10	120
					6		25	6	360	
					12		22	4	720	
					20	10	3	1200		
		GLTH8 GLCH8	200W	80	±0.005	14	6	80	15	360
							12	60	8	720
							24	40	5	1440
			400W				6	105	30	360
							12	85	20	720
							24	40	10	1440
		GLTH12 GLCH12	400W	120	±0.005	14	6	110	30	360
							12	88	20	720
							24	40	10	1440
		GLTH5D GLCH5D 雙滑座 Dual Carriage	100W	52	±0.005	10	2	30	10	120
					6		25	6	360	
					12		22	4	720	
							20	10	3	1200
		GLTH8D GLCH8D 雙滑座 Dual Carriage	200W	80	±0.005	14	6	80	15	360
		12	60				8	720		
		24	40				5	1440		
	400W	6	105				30	360		
					12	85	20	720		
					24	40	10	1440		
GLMH5	100W	52	±0.005	10	2	30	10	120		
			6		25	6	360			
			12		22	4	720			
					20	10	3	1200		
GLMH8	200W	80	±0.005	14	6	80	15	360		
					12	60	8	720		
					24	40	5	1440		
	400W				6	105	30	360		
					12	85	20	720		
					24	40	10	1440		
GLTH5M 長行程 Long Stroke	100W	52	±0.005	10	2	30	10	120		
			6		25	6	360			
			12		22	4	720			
					20	10	3	1200		
GLTH8M 長行程 Long Stroke	200W	80	±0.005	14	6	80	15	360		
					12	60	8	720		
					24	40	5	1440		
	400W				6	105	30	360		
					12	85	20	720		
					24	40	10	1440		

*1: 標準行程內的黑色數字，代表該行程內可使用的最高安全速度。若超過此速度，滑台可能會有嚴重共振產生。
Written here is the standard stroke's maximum safe speed. If over this speed, it may casue serious vibration.

*2: GLCH 無塵等級可達 class 10。
GLCH achieves a cleanroom level of up to class 10.

GLTB/GLCB 扁平型軌道內嵌式皮帶驅動系列

GLTB/GLCB Built-in Linear Motion Guide Belt Drive Actuator-Slider Type

使用環境 Environment	傳動方式 Driven Mode	仕様 Specification	馬達容量 Motor Output (w)	本體寬幅 Width(mm)	位置重複精度 Repeatability(mm)	皮帶規格 Belt Spec		最大可搬重量 Maximum Payload(kg)		最高速度 ^{*1} Maximum Speed (mm/s)
						寬度 Belt Width(mm)	導程 Lead(mm)	水平使用 Horizontal	垂直使用 Vertical	
一般環境 Standard	皮帶 Belt	GLTB5 GLCB5	100W	52	±0.06	9	32	5	-	1067
		GLTB8 GLCB8	400W	80	±0.06	8	60	8	-	2000

*1: GLTB 馬達最高轉速以 2000RPM 為計算基準。
3000RPM for motor as standard for GLTB.

*2: 標準行程內的黑色數字，代表該行程內可使用的最高安全速度。若超過此速度，滑台可能會有嚴重共振產生。
Written here is the standard stroke's maximum safe speed. If over this speed, it may casue serious vibration.

*3: GLCB5 無塵等級可達 class 10，GLCB8 的無塵等級僅能達 class 100。
GLCB5 achieves a cleanroom level of up to class 10, while GLCB8 only achieves a cleanroom level of up to class 100.

標準行程及最高使用速度^{*1}
Stroke(mm) & Maximum Speed(mm/s)

代表速度 Speed

頁數
Page

行程 Stroke	50	100	150	200	250	300	350	400	450	500	550	600	650	700	750	800	850	900	950	1000	1050	1100	1150	1200	1250	1300	1350			
120				107	90	80	70	60	50	40																			10	
480				427	360	320	280	240	200	160																				
		120									110	90	80	70	63	53	50	43	40	36										14
		360									330	270	240	210	190	160	150	130	120	110									74	
		720									660	540	480	420	380	320	300	260	240	220										
		1200									1100	900	800	700	630	533	500	430	400	367										
		360									350	310	270	240	210	190	170	160	140	130	120	110	100	90					18	
		720									700	620	540	480	420	380	340	320	280	260	240	220	200	180					78	
		1440									1400	1240	1080	960	840	760	680	640	560	520	480	440	400	360						
		360									350	310	270	240	210	190	170	160	140	130	120	110	100	90						
		720									700	620	540	480	420	380	340	320	280	260	240	220	200	180						
		1440									1400	1240	1080	960	840	760	680	640	560	520	480	440	400	360						
		360									350	310	270	240	210	190	170	160	140	130	120	110	100	90					26	
		720									700	620	540	480	420	380	340	320	280	260	240	220	200	180					86	
		1440									1400	1240	1080	960	840	760	680	640	560	520	480	440	400	360						
	120										110	90	80	70	63	53	50	43	40	36									30	
	360										330	270	240	210	190	160	150	130	120	110									90	
	720										660	540	480	420	380	320	300	260	240	220										
	1200										1100	900	800	700	633	533	500	433	400	367										
	360										350	310	270	240	210	190	170	160	140	130	120	110	100	90						
	720										700	620	540	480	420	380	340	320	280	260	240	220	200	180						
	1440										1400	1240	1080	960	840	760	680	640	560	520	480	440	400	360						
	360										350	310	270	240	210	190	170	160	140	130	120	110	100	90						
	720										700	620	540	480	420	380	340	320	280	260	240	220	200	180						
	1440										1400	1240	1080	960	840	760	680	640	560	520	480	440	400	360						
行程 Stroke	50	100	150	200	250	300	350	400	450	500	550	600	650	700	750	800	850	900	950	1000	1050	1100	1150	1200	1250	1300	1350			
120											110	90	80	70	63	53	50	43	40	36									42	
360											330	270	240	210	190	160	150	130	120	110										
720											660	540	480	420	380	320	300	260	240	220										
1200											1100	900	800	700	633	533	500	433	400	367										
360											350	310	270	240	210	190	170	160	140	130	120	110	100	90						
720											700	620	540	480	420	380	340	320	280	260	240	220	200	180						
1440											1400	1240	1080	960	840	760	680	640	560	520	480	440	400	360						
650	700	950	1000	1050	1100	1150	1200	1250	1300	1350	1400	1450	1500	1550	1600	1650	1700	1750	1800	1850	1900	1950	2000	2100	2200	2300	2350	2400	2450	2500
120			110	100	93	86	80	76	70	66	63	60	56	53	50	46	43	40	33	30	26	23								
360			330	300	280	260	240	230	210	200	190	180	170	160	150	140	130	120	100	90	80	70								
720			660	600	560	520	480	460	420	400	380	360	340	320	300	280	260	240	200	180	160	140								
1200			1100	1000	933	867	800	767	700	667	633	600	567	533	500	467	433	400	333	300	267	233								
360			320	300	280	260	250	230	220	210	200	190	180	170	160	150	140	130	120	110	100	90	80	70	60					
720			640	600	560	520	500	460	440	420	400	380	360	340	320	300	280	260	240	220	200	180	160	140	120					
1440			1280	1200	1120	1040	1000	920	880	840	800	760	720	680	640	600	560	520	480	440	400	360	320	280	240					
360			320	300	280	260	250	230	220	210	200	190	180	170	160	150	140	130	120	110	100	90	80	70	60					
720			640	600	560	520	500	460	440	420	400	380	360	340	320	300	280	260	240	220	200	180	160	140	120					
1440			1280	1200	1120	1040	1000	920	880	840	800	760	720	680	640	600	560	520	480	440	400	360	320	280	240					

標準行程及最高使用速度^{*2}
Stroke(mm) & Maximum Speed(mm/s)

代表速度 Speed

頁數
Page

行程 Stroke	50	100	200	300	400	500	600	700	800	900	1000	1100	1200	1300	1400	1500	1600	1700	1800	1900	2000	2200	2400	2600	2800	3000	3200		
																													66
																													102
																													70
																													106

GLTH3 單軸 /1-axis

▶ 軌道內嵌
Integrated Linear Bearing

▶ 螺桿驅動
Ball Screw Drive

精度
±0.005 mm

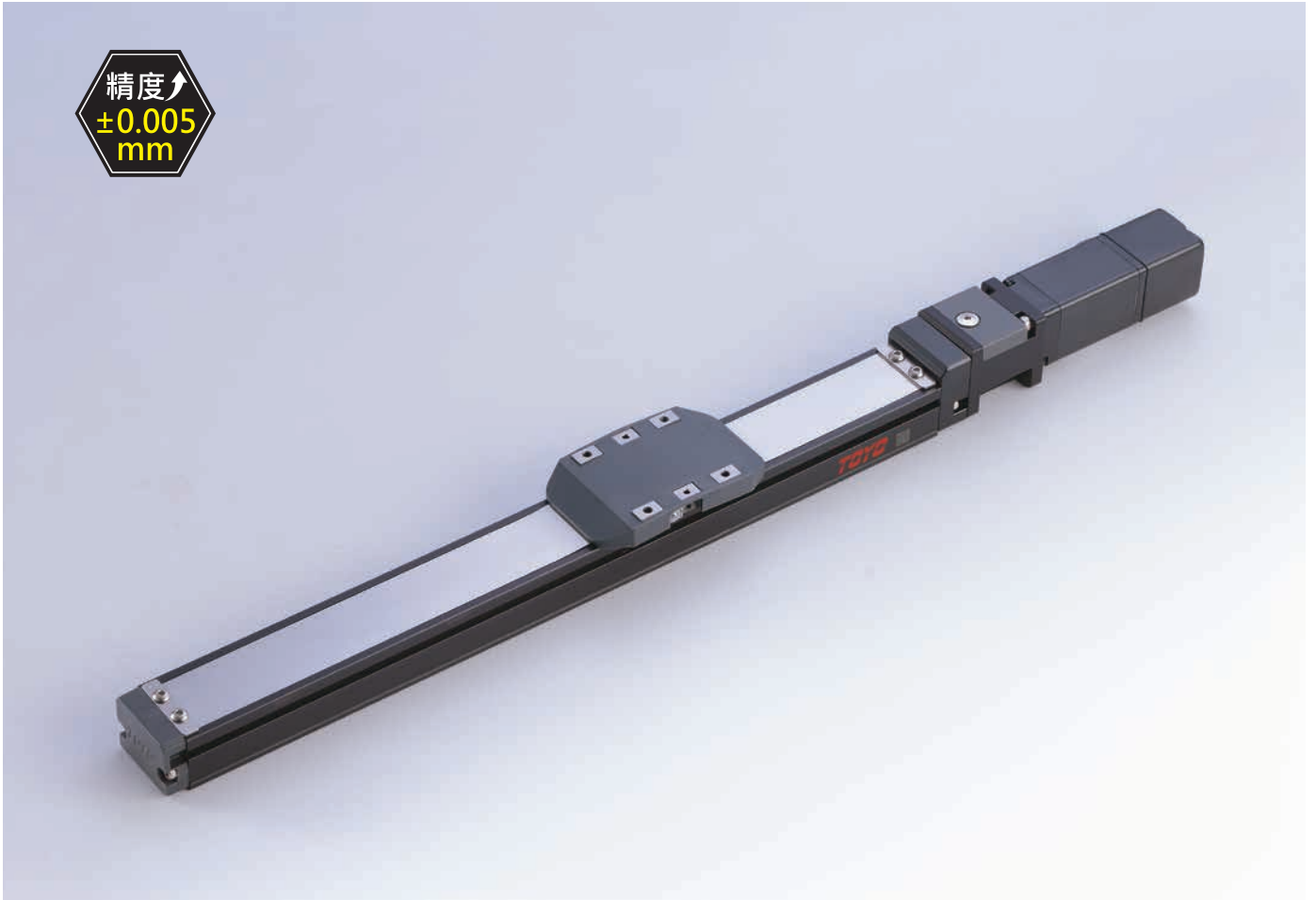

最大行程
Maximum Stroke 500mm

最高速度
Maximum Speed 480mm/s

馬達容量
Motor Output 30W

最大可搬重量
Max Payload 13kg

型號表示方式 Ordering Method

GLTH3 - L2 - 100 - BC - M03B - C4N5 - 參照右頁
Refer to the right page - 0001

本體型號
Model

行程^{*1}
Stroke

50-500mm
50間隔 50 mm Pitch

選配
Options

特注式樣
Customization Order No.

馬達位置
Motor Position

BC	馬達外露 Motor Exposed
BM	馬達下折 Motor Bottom Side
BL	馬達左折 Motor Left Side
BR	馬達右折 Motor Right Side

馬達廠牌、功率
Motor Brand · Power Output

M	三菱 Mitsubishi	03	30W	B ^{*2}
P	松下 Panasonic	10	-	
Y	安川 Yaskawa	20	-	
T	台達 Delta	40	-	

原點感應器
Home Sensor

外掛型 Out Side	
C	馬達側 Motor Side
D	反馬達側 Opposite Motor Side
無 SENSOR No Sensor	
E	無 SENSOR No Sensor

端點極限感應器
Limit Sensor

外掛型 Out Side	
3	1只 1 Pc
4	2只 2 Pcs
6	3只 3 Pcs
7	4只 4 Pcs
8	5只 5 Pcs
9	6只 6 Pcs
無 SENSOR No Sensor	
5	無 SENSOR No Sensor

輸出方式&線長
Output type & Cable length

N5	NPN+5米線 NPN+5M Cable
P2	PNP+2米線 PNP+2M Cable
P5	PNP+5米線 PNP+5M Cable
-	NPN+2米線 NPN+2M Cable

螺桿導程
Ball Screw Lead

2	2mm
8	8mm

^{*1} 選擇行程50時, 光電使用有以下限制: When the stroke is 50mm, the sensor installation has the following restrictions:

馬達方向 BC/BM: 1.原點與極限需放置於不同側。2.滑座左右兩側皆需安裝感應片。Motor Direction BC/BM 1.Home sensor and limit sensor has to be installed on the different side of body. 2.Both sides of slider need to install the sensor trigger device.
馬達方向 BL/BR: 1.原點+極限感應器最數量最多2只(僅能選用C3/D3/E3/E4/E5)。Motor Direction BL/BR 1.Home + limit sensors is 2 maximum (only C3/D3/E3/E4/E5 can be selected)

^{*2} 馬達若無煞車則不表示。If Motor No Brake, No Description.

基本仕様 Specification

性能	位置重複精度 Repeatability	mm	±0.005		
	螺桿導程 Lead	mm	2	8	
	最高轉速 Maximum Rotating speed	rpm	3600	3600	
	最高速度 Maximum linear speed ^{**1}	mm/s	120	480	
	最大可搬重量 Maximum Payload	水平使用 Horizontal	kg	13	10
		垂直使用 Vertical	kg	5	2
	定格推力 Rated Thrust	N	352	88	
	標準行程 Stroke (increments)	mm	50-500mm / 50 間隔 (50 increments)		
	最大加速度 Maximum acceleration	G	0.3	0.3	
	滾珠螺桿 Ball screw	基本動額定負荷 Basic dynamic load rating Ca	N	1811	862
基本靜額定負荷 Basic static load rating Coa		N	2774	1099	
直線滑軌 Linear Guide	動態水平負載 Dynamic horizontal (100km)	N	3144		
	靜態水平負載 Static Horizontal	N	6707		
固定側軸承 Fixed bearing	基本動額定負荷 Basic dynamic load rating Cr	N	2819		
	靜態容許負荷 Static load rating Cor	N	1342		
部品	AC 伺服馬達容量 AC Servo Motor Output	W	30		
	滾珠螺桿外徑 Ball Screw Ø	mm	C7Ø6		
	連軸器 Coupling	mm	4X5		
	原點感應器 Home Sensor	外掛 Outside	T64N2 (NPN+2 米線) (NPN+2M Cable)		

^{**1}長行程時，會產生螺桿偏擺，需將速度調降 (線速度請參閱尺寸圖下方表格)
During in a long stroke, it causes ballscrew deflection, the speed must reduce. (Please refer to the linear velocity from the data sheet below the dimension graph.)

容許負載力距表 Allowable Overhang

(單位 Unit: mm)				(單位 Unit: mm)				(單位 Unit: mm)					
水平安裝 Horizontal Installation				壁掛安裝 Wall Installation				垂直安裝 Vertical Installation					
導程 2 Lead	10kg	364	13	15	10kg	15	13	364	導程 2 Lead	3kg	55	55	
	12kg	260	10	11	12kg	11	10	260		導程 8 Lead	5kg	33	33
	13kg	266	9	10	13kg	10	9	266			-	-	-
導程 8 Lead	6kg	117	17	18	6kg	18	17	117	導程 8 Lead	1kg	120	120	
	8kg	84	12	12	8kg	12	12	84		2kg	60	60	
	10kg	64	9	9	10kg	9	9	64		-	-	-	

靜額定扭矩 Static Loading Moment

(單位 Unit: N.m)		
MY		39
MP		39
MR		44

*力矩表所表示的數據，代表荷重的重心位置於單一方向容許懸出的長度。
The data represented by the moment table is the center of gravity of the load. The length of the overhang is allowed in a single direction.
*符合型錄規範的正常使用下，保證壽命為 10000 公里。
Operation life is 10,000km when the product is using under the specified conditions.
*倒吊使用無法套用標準規範，如有需求請諮詢我司業務。
Data information is not for ceiling-mount inverse use. Contact us for the details if you want to apply ceiling-mount inverse usage.
*壽命及力矩是以馬達加減速設定 0.2 秒計算。
The life and torque are calculated by setting the motor acceleration and deceleration for 0.2 seconds.

選配 Options

MM

指定馬達出線方向 Selectable Cable Leading Direction		
代號 Code	說明 Instructions	需參照 Refer to
MW	朝上 Upper side	P.111 ~ P.112
MM	朝下 Bottom side	
ML	朝左 Left side	
MR	朝右 Right side	

CMK

馬達傳動配件追加鍵槽 Additional keyway for motor drive parts				
代號 Code	說明 Instructions			需參照 Refer to
	追加鍵槽 Keyway Groove	馬達位置 Motor Position	出貨型式 Shipment Type	
CMK	單邊 (限定馬達側) Single (Limited to the motor side)	BC	鍵槽式聯軸器 Keyway Coupling	P.113 ~ P.115
		BL/BR/BM	鍵槽式皮帶輪 Keyway Belt Pulley	
SKY	雙邊 Double	BC	鍵槽式聯軸器 Keyway Coupling	
		BL/BR/BM	鍵槽式皮帶輪 Keyway Belt Pulley	
SKN	雙邊 Double	BC	無聯軸器 (請自行購買安裝) Without Coupling (Please purchase and install by yourself)	
		BL/BR/BM	無馬達端皮帶輪 (請自行購買安裝) Without Belt Pulley (Please purchase and install by yourself)	

GLTH Series

- GLTH3
- GLTH5
- GLTH8
- GLTH12
- GLTH5D
- GLTH8D
- GLMH5
- GLMH8
- GLTH5M
- GLTH8M



Download at www.toyorobot.com

BC 馬達外露 Motor Exposed

單位 Unit : mm

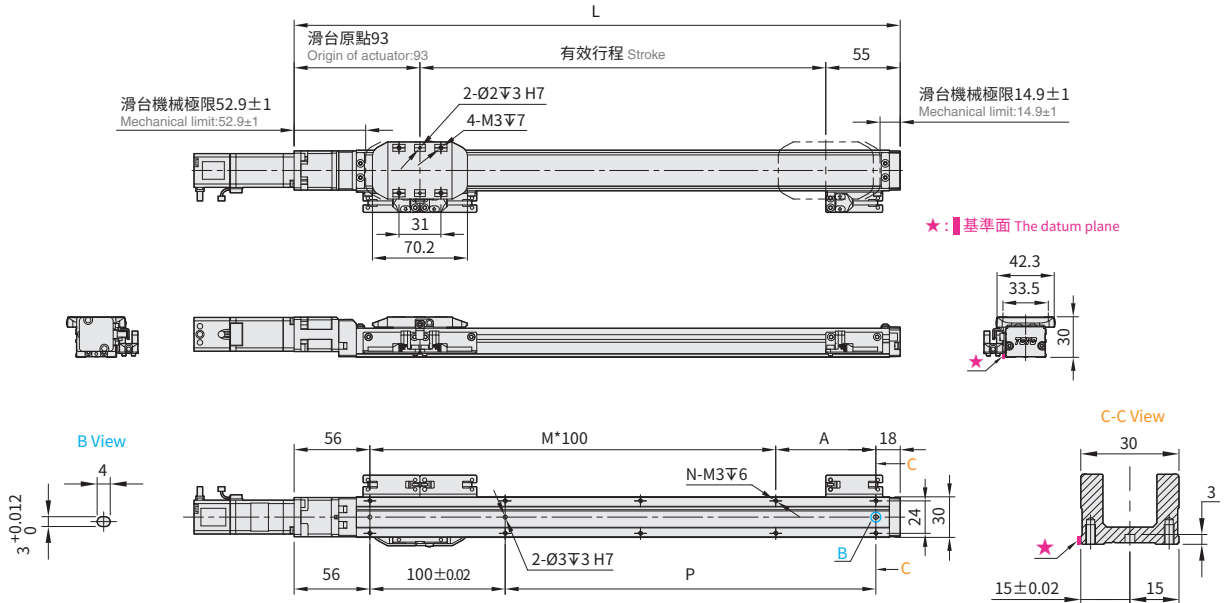

BM 馬達下折 Motor Bottom Side

單位 Unit : mm

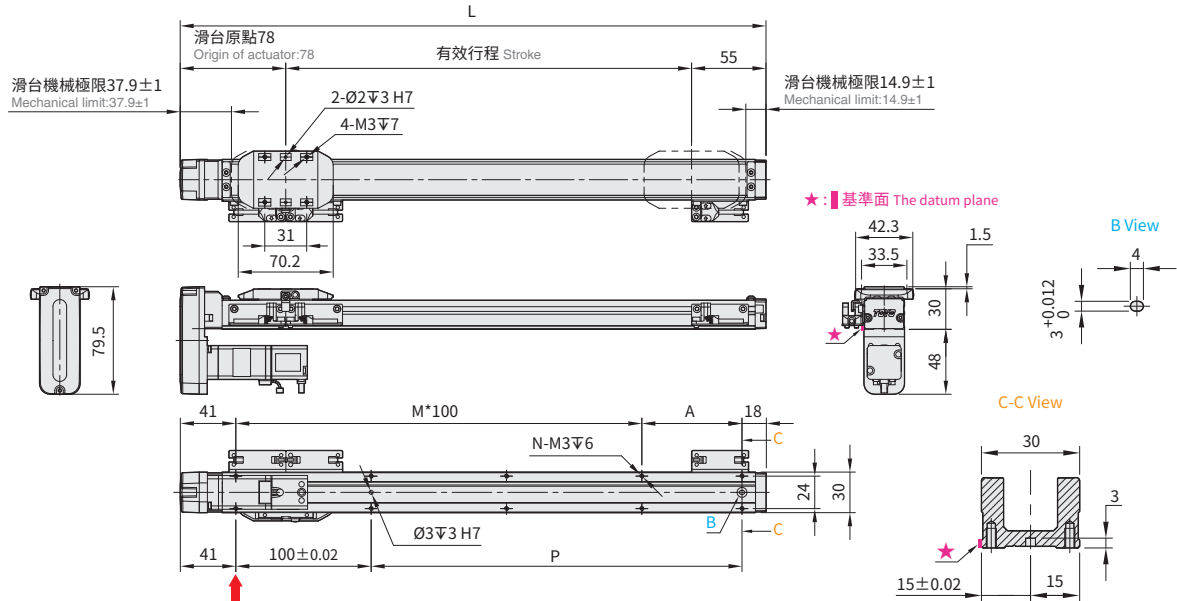

* 此處固定孔會被馬達遮住，規劃時請注意。
Please note that this thread hole will be covered by motor.

有效行程 Stroke		50	100	150	200	250	300	350	400	450	500
極限行程 Limit Stroke (±1)		60	110	160	210	260	310	360	410	460	510
L	BC	198	248	298	348	398	448	498	548	598	648
	BM	183	233	283	333	383	433	483	533	583	633
A		24	74	124	174	224	274	324	374	424	474
M		1	1	2	2	3	3	4	4	5	5
N		6	6	8	8	10	10	12	12	14	14
P		24	74	124	174	224	274	324	374	424	474
KG	BC	0.29	0.34	0.4	0.44	0.49	0.55	0.61	0.67	0.73	0.79
	BM	0.38	0.48	0.57	0.66	0.76	0.85	0.94	1.03	1.12	1.21
線速度 Linear Speed mm/s	導程 Lead 2	120		107	90	80	70	60	50	40	
	導程 Lead 8	480		427	360	320	280	240	200	160	



Download at www.toyorobot.com

BL 馬達左折 Motor Left Side

單位 Unit : mm

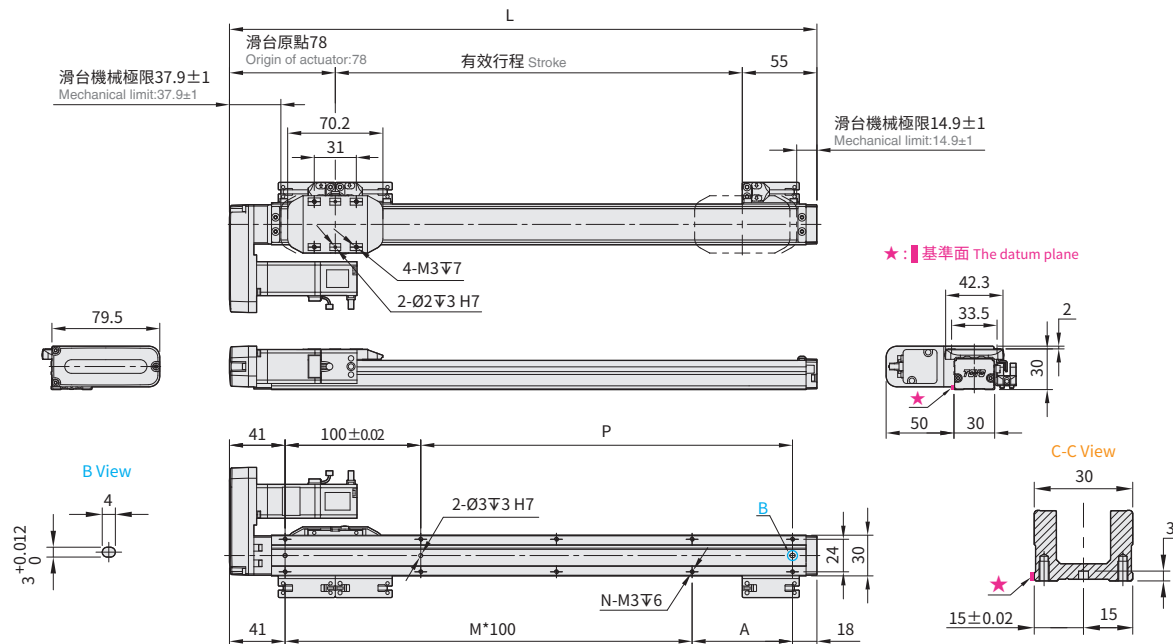

BR 馬達右折 Motor Right Side

單位 Unit : mm

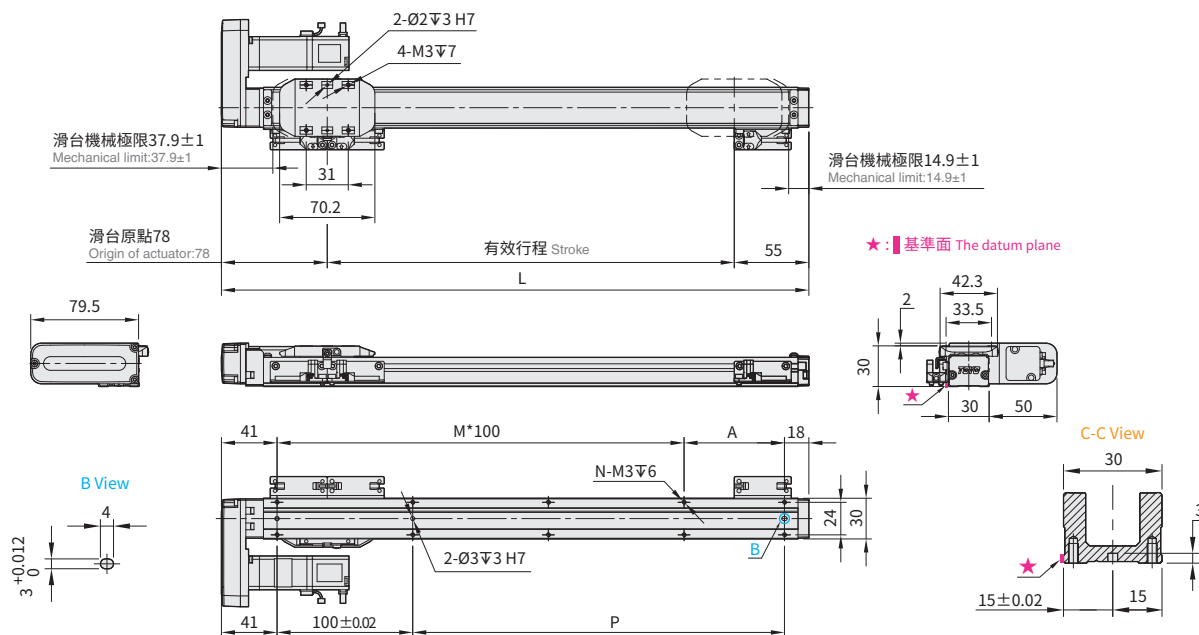

有效行程 Stroke	50	100	150	200	250	300	350	400	450	500
極限行程 Limit Stroke (±1)	60	110	160	210	260	310	360	410	460	510
L	183	233	283	333	383	433	483	533	583	633
A	24	74	24	74	24	74	24	74	24	74
M	1	1	2	2	3	3	4	4	5	5
N	6	6	8	8	10	10	12	12	14	14
P	24	74	124	174	224	274	324	374	424	474
KG	0.38	0.48	0.57	0.66	0.76	0.85	0.94	1.03	1.12	1.21
線速度 Linear Speedmm/s	導程 Lead 2	120								
	導程 Lead 8	480								
				107	90	80	70	60	50	40
				427	360	320	280	240	200	160

應用例
Application

一般 / 螺桿仕様
GLTH

一般 / 皮帶仕様
ETB / M

無塵 / 螺桿仕様
GCH / ECH

無塵 / 皮帶仕様
ECB

直交連結
XYGT / XTH / XYTB

參考資料
Reference

GLTH Series

GLTH3

GLTH5

GLTH8

GLTH12

GLTH5D

GLTH8D

GLMH5

GLMH8

GLTH5M

GLTH8M

精度
±0.005 mm



最大行程
Maximum Stroke 1000mm

最高速度
Maximum Speed 1200mm/s

馬達容量
Motor Output 100W

最大可搬重量
Max Payload 30kg

型號表示方式 Ordering Method

GLTH5 - L2 - 100 - BC - M10B - C4N5 - 參照右頁
Refer to the right page - 0001

本體型號
Model

行程^{*1}
Stroke

50-1000mm
50間隔 50 mm Pitch

選配
Options

特注式樣
Customization Order No.

螺桿導程
Ball Screw Lead

2	2mm
6	6mm
12	12mm
20	20mm

馬達位置
Motor Position

BC	馬達外露 Motor Exposed
BM	馬達下折 Motor Bottom Side
BL	馬達左折 Motor Left Side
BR	馬達右折 Motor Right Side

馬達廠牌、功率
Motor Brand · Power Output

M	三菱 Mitsubishi	05	-	B ^{*2}
P	松下 Panasonic	10	100W	
Y	安川 Yaskawa	20	-	
T	台達 Delta	40	-	

原點感應器
Home Sensor

外掛型 Out Side	
C	馬達側 Motor Side
D	反馬達側 Opposite Motor Side
無 SENSOR No Sensor	
E	無 SENSOR No Sensor

端點極限感應器
Limit Sensor

外掛型 Out Side	
3	1只 1 Pc
4	2只 2 Pcs
6	3只 3 Pcs
7	4只 4 Pcs
8	5只 5 Pcs
9	6只 6 Pcs
無 SENSOR No Sensor	
5	無 SENSOR No Sensor

輸出方式&線長
Output type & Cable length

N5	NPN+5米線 NPN+5M Cable
P2	PNP+2米線 PNP+2M Cable
P5	PNP+5米線 PNP+5M Cable
-	NPN+2米線 NPN+2M Cable

^{*1} 選擇行程50時，光電使用有以下限制：When the stroke is 50mm, the sensor installation has the following restrictions:

馬達方向 BC/BM：1.原點與極限需放置於不同側。2.滑座左右兩側皆需安裝感應片。Motor Direction BC/BM 1.Home sensor and limit sensor has to be installed on the different side of body. 2.Both sides of slider need to install the sensor trigger device.

馬達方向 BL/BR：1.原點+極限感應器最數量最多2只 (僅能選用C3/D3/E3/E4/E5)。Motor Direction BL/BR 1.Home + limit sensors is 2 maximum (only C3/D3/E3/E4/E5 can be selected)

^{*2} 馬達若無煞車則不表示。If Motor No Brake, No Description.

基本仕様 Specification

性能	位置重複精度 Repeatability	mm	±0.005				
	螺桿導程 Lead	mm	2	6	12	20	
	最高轉速 Maximum Rotating speed	rpm	3600	3600	3600	3600	
	最高速度 Maximum linear speed ^{※1}	mm/s	120	300	720	1200	
	最大可搬重量 ^{※2} Maximum Payload	水平使用 Horizontal	kg	30	25	22	10
		垂直使用 Vertical	kg	10	6	4	3
	定格推力 Rated Thrust	N	854	285	142	85	
	標準行程 Stroke (increments)	mm	50-1000mm /50 間隔 (50 increments)				
	最大加速度 Maximum acceleration	G	0.12	0.37	0.73	1.22	
	滾珠螺桿 Ball screw	基本動額定負荷 Basic dynamic load rating Ca	N	2270	2243	1436	1384
基本靜額定負荷 Basic static load rating Coa		N	4836	3959	2441	2535	
直線滑軌 Linear Guide	動態水平負載 Dynamic horizontal (100km)	N	6563				
	靜態水平負載 Static Horizontal	N	13587				
固定側軸承 Fixed bearing	基本動額定負荷 Basic dynamic load rating Cr	N	5361				
	靜態容許負荷 Static load rating Cor	N	2880				
部品	AC 伺服馬達容量 AC Servo Motor Output	W	100				
	滾珠螺桿外徑 Ball Screw Ø	mm	C7Ø10				
	連軸器 Coupling	mm	7X8				
	原點感應器 Home Sensor	外掛 Outside	T64N2 (NPN+2 米線) (NPN+2M Cable)				

※1 長行程時，會產生螺桿偏擺，需將速度調降 (線速度請參閱尺寸圖下方表格)

During in a long stroke, it causes ballscrew deflection, the speed must reduce. (Please refer to the linear velocity from the data sheet below the dimension graph.)

※2 由於各廠牌的馬達性能不同，需適度搭配回升電阻以達到此荷重條件。

Since the motor performance of each brand is different, a regenerative resistor needs to be appropriately matched to achieve this load condition.

容許負載力距表 Allowable Overhang

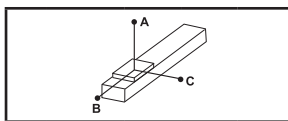

(單位 Unit: mm)

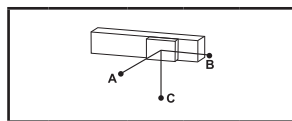

(單位 Unit: mm)

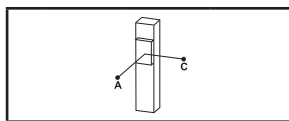

(單位 Unit: mm)

水平安裝 Horizontal Installation		A	B	C
導程 2 Lead	10kg	2500	157	250
	20kg	1120	70	112
	30kg	650	41	65
導程 6 Lead	10kg	1400	122	184
	20kg	650	52	79
	25kg	490	38	57
導程 12 Lead	8kg	590	132	175
	10kg	460	103	135
	22kg	185	37	49
導程 20 Lead	3kg	656	300	303
	6kg	314	141	144
	10kg	177	78	79

壁掛安裝 Wall Installation		A	B	C
導程 2 Lead	10kg	250	157	2500
	20kg	112	70	1120
	30kg	65	41	650
導程 6 Lead	10kg	184	122	1400
	20kg	79	52	650
	25kg	57	38	490
導程 12 Lead	8kg	175	132	590
	10kg	135	103	460
	22kg	49	37	185
導程 20 Lead	3kg	303	300	656
	6kg	144	141	314
	10kg	79	78	177

垂直安裝 Vertical Installation		A	C
導程 2 Lead	5kg	346	346
	10kg	173	173
	-	-	-
導程 6 Lead	3kg	463	463
	6kg	231	231
	-	-	-
導程 12 Lead	2.5kg	465	465
	4kg	292	292
	-	-	-
導程 20 Lead	1.5kg	555	555
	3g	278	278
	-	-	-

靜額定扭矩 Static Loading Moment

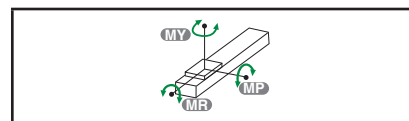

(單位 Unit: N.m)

MY	73
MP	73
MR	115

* 力矩表所表示的數據，代表荷重的重心位置於單一方向容許懸出的長度。
The data represented by the moment table is the center of gravity of the load. The length of the overhang is allowed in a single direction.

* 符合型錄規範的正常使用下，保證壽命為 10000 公里。

Operation life is 10,000km when the product is using under the specified conditions.

* 倒吊使用無法套用標準規範，如有需求請洽詢我司業務。

Data information is not for ceiling-mount inverse use. Contact us for the details if you want to apply ceiling-mount inverse usage.

* 壽命及力矩是以馬達加減速設定 0.2 秒計算。

The life and torque are calculated by setting the motor acceleration and deceleration for 0.2 seconds.

選配 Options

MM

指定馬達出線方向 Selectable Cable Leading Direction		
代號 Code	說明 Instructions	需參照 Refer to
MW	朝上 Upper side	P.111 ~ P.112
MM	朝下 Bottom side	
ML	朝左 Left side	
MR	朝右 Right side	

CMK

馬達傳動配件追加鍵槽 Additional keyway for motor drive parts				
代號 Code	說明 Instructions			需參照 Refer to
	追加鍵槽 Keyway Groove	馬達位置 Motor Position	出貨型式 Shipment Type	
CMK	單邊 (限定馬達側) Single (Limited to the motor side)	BC	鍵槽式聯軸器 Keyway Coupling	P.113 ~ P.115
		BL/BR/BM	鍵槽式皮帶輪 Keyway Belt Pulley	
SKY	雙邊 Double	BC	鍵槽式聯軸器 Keyway Coupling	
		BL/BR/BM	鍵槽式皮帶輪 Keyway Belt Pulley	
SKN	雙邊 Double	BC	無聯軸器 (請自行購買安裝) Without Coupling (Please purchase and install by yourself)	
		BL/BR/BM	無馬達端皮帶輪 (請自行購買安裝) Without Belt Pulley (Please purchase and install by yourself)	

GLCH Series

GLTH3

GLTH5

GLTH8

GLTH12

GLTH5D

GLTH8D

GLMH5

GLMH8

GLTH5M

GLTH8M



• Download at www.toyorobot.com •

BC 馬達外露 Motor Exposed

單位 Unit : mm

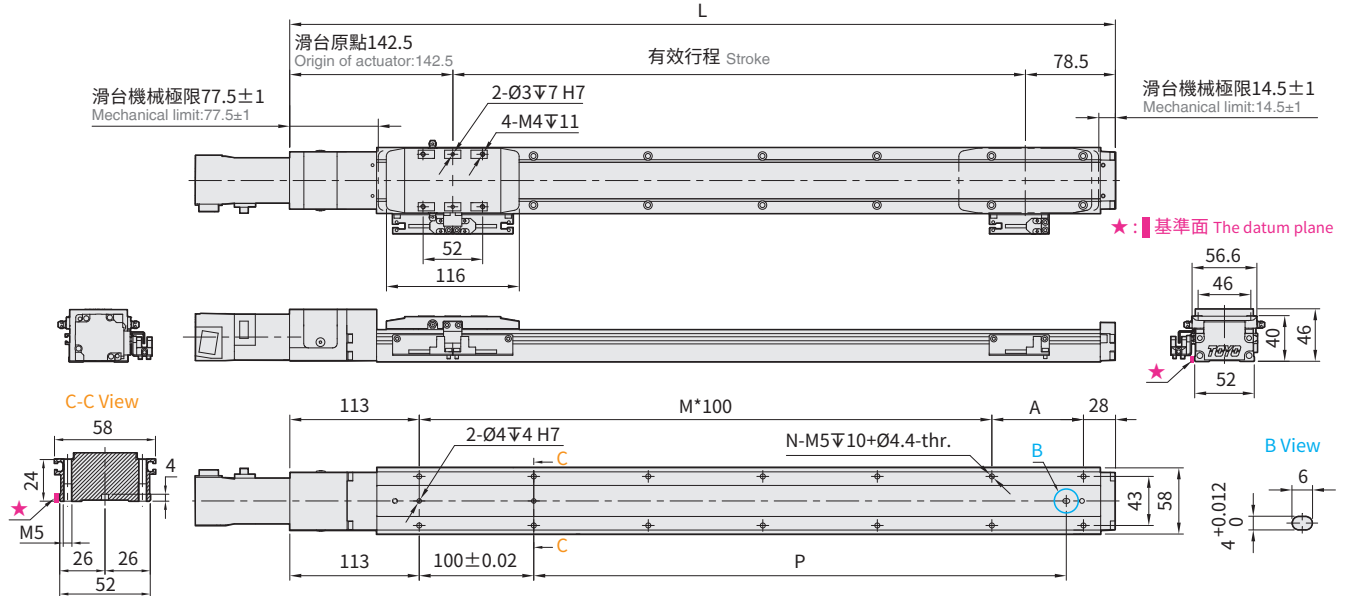

BM 馬達下折 Motor Bottom Side

單位 Unit : mm

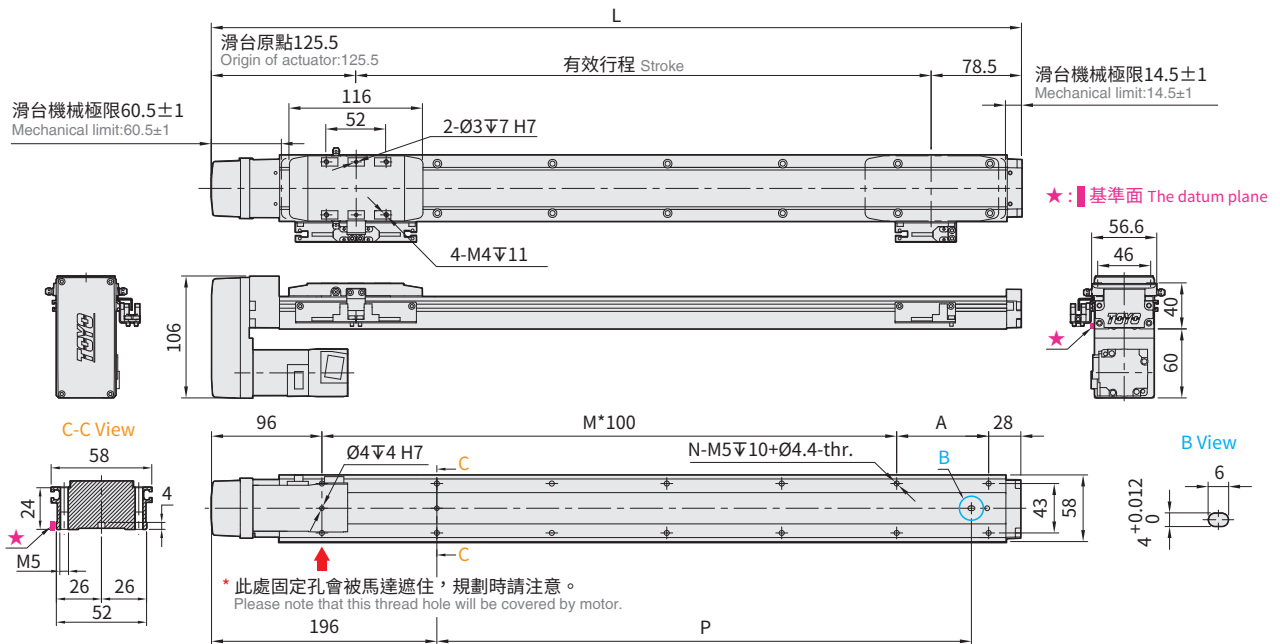

有效行程 Stroke	50 ⁻¹	100	150	200	250	300	350	400	450	500	550	600	650	700	750	800	850	900	950	1000			
極限行程 Limit Stroke (±1)	63	113	163	213	263	313	363	413	463	513	563	613	663	713	763	813	863	913	963	1013			
L	BC	271	321	371	421	471	521	571	621	671	721	771	821	871	921	971	1021	1071	1121	1171	1221		
	BM	254	304	354	404	454	504	554	604	654	704	754	804	854	904	954	1004	1054	1104	1154	1204		
A	30	80	30	80	30	80	30	80	30	80	30	80	30	80	30	80	30	80	30	80	30	80	
M	1	1	2	2	3	3	4	4	5	5	6	6	7	7	8	8	9	9	10	10	10	10	
N	6	6	8	8	10	10	12	12	14	14	16	16	18	18	20	20	22	22	24	24	24	24	
P	15	65	115	165	215	265	315	365	415	465	515	565	615	665	715	765	815	865	915	965	965	965	
KG	MC	1.06	1.19	1.32	1.44	1.57	1.69	1.82	1.95	2.07	2.2	2.33	2.45	2.58	2.71	2.83	2.96	3.08	3.21	3.34	3.46	3.46	
	BM	1.16	1.29	1.42	1.54	1.67	1.79	1.92	2.05	2.17	2.3	2.43	2.55	2.68	2.81	2.93	3.06	3.18	3.31	3.44	3.56	3.56	
線速度 Linear Speed mm/s	導程 Lead 2	120										110	90	80	70	63	53	50	43	40	36	36	
	導程 Lead 6	360										330	270	240	210	190	160	150	130	120	110	110	110
	導程 Lead 12	720										660	540	480	420	380	320	300	260	240	220	220	220
	導程 Lead 20	1200										1100	900	800	700	630	533	500	430	400	367	367	367

※1行程50時，因本體上鎖式固定孔會被滑座遮住，僅能使用4支螺絲固定，建議客戶本體使用下鎖式固定孔鎖附。When the stroke is 50mm, if fixing the body from the top to the bottom, the fixing hole will be blocked by slider and only can be uses 4 screws to fix; as a result, suggest that fixing actuator body from the bottom to the top.



Download at www.toyorobot.com

BL 馬達左折 Motor Left Side

單位 Unit : mm

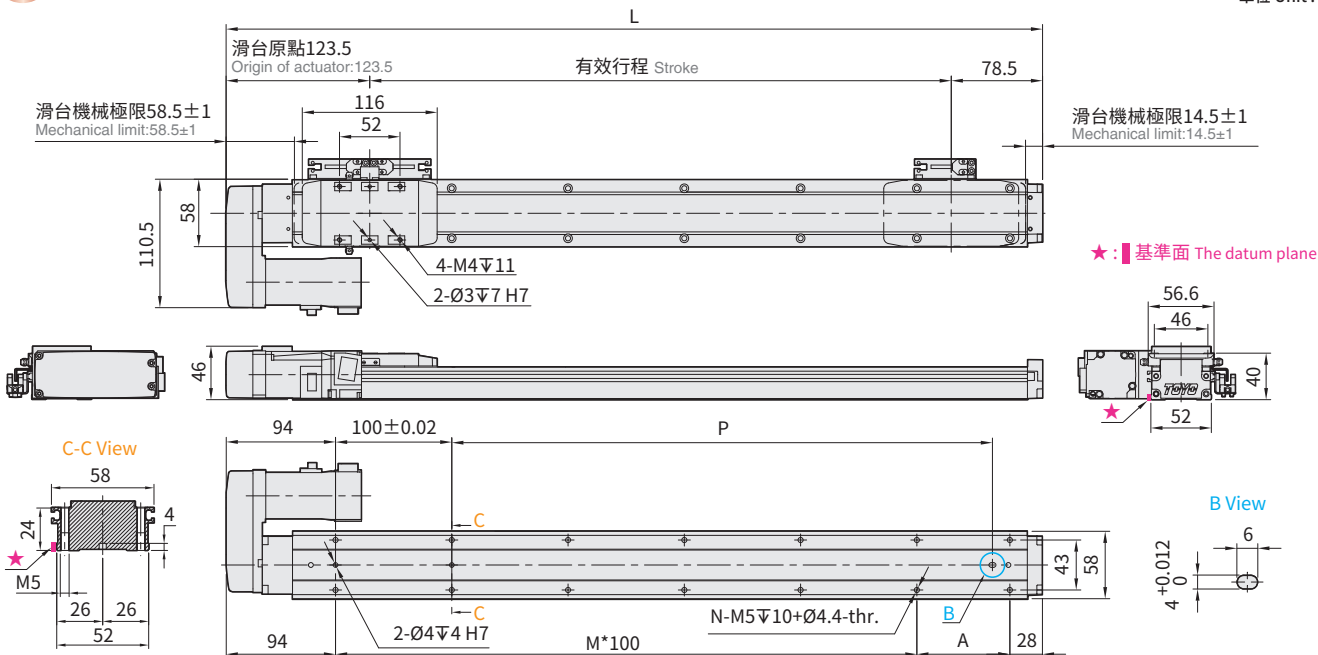

BR 馬達右折 Motor Right Side

單位 Unit : mm

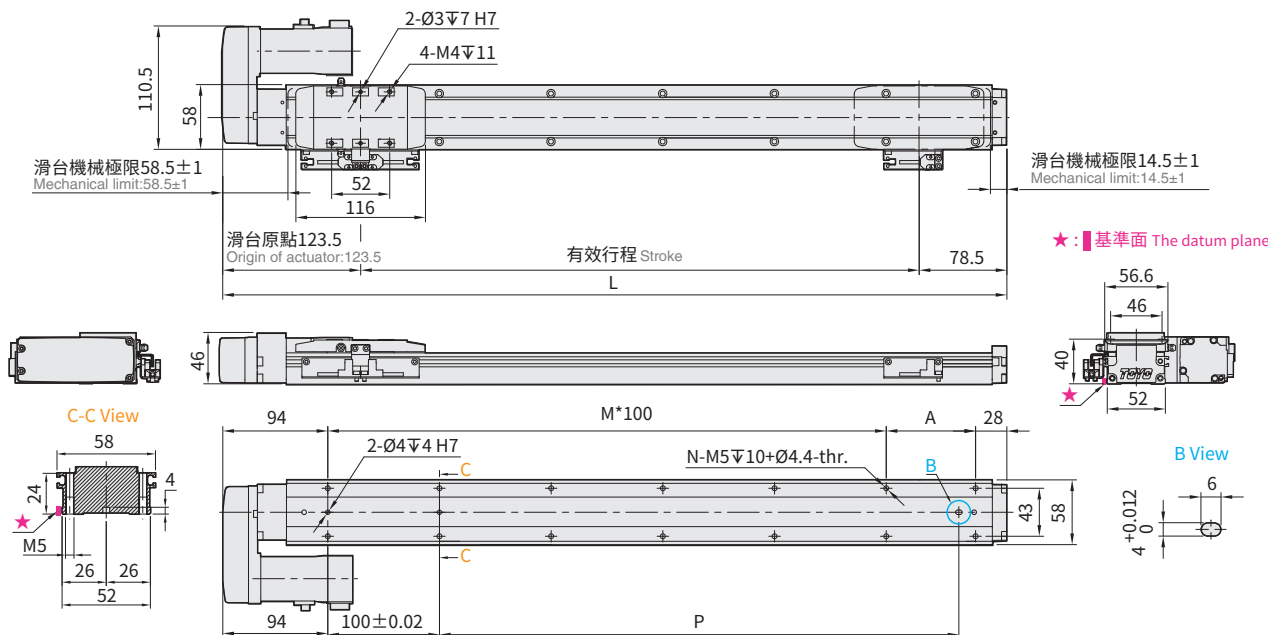

有效行程 Stroke	50 ^{※1}	100	150	200	250	300	350	400	450	500	550	600	650	700	750	800	850	900	950	1000	
極限行程 Limit Stroke (±1)	63	113	163	213	263	313	363	413	463	513	563	613	663	713	763	813	863	913	963	1013	
L	252	302	352	402	452	502	552	602	652	702	752	802	852	902	952	1002	1052	1102	1152	1202	
A	30	80	30	80	30	80	30	80	30	80	30	80	30	80	30	80	30	80	30	80	
M	1	1	2	2	3	3	4	4	5	5	6	6	7	7	8	8	9	9	10	10	
N	6	6	8	8	10	10	12	12	14	14	16	16	18	18	20	20	22	22	24	24	
P	15	65	115	165	215	265	315	365	415	465	515	565	615	665	715	765	815	865	915	965	
KG	1.16	1.29	1.42	1.54	1.67	1.79	1.92	2.05	2.17	2.3	2.43	2.55	2.68	2.81	2.93	3.06	3.18	3.31	3.44	3.56	
線速度 Linear Speed mm/s	導程 Lead 2										120	110	90	80	70	63	53	50	43	40	36
	導程 Lead 6										360	330	270	240	210	190	160	150	130	120	110
	導程 Lead 12										720	630	540	480	420	380	320	300	260	240	240
	導程 Lead 20										1200	1100	900	800	700	630	533	500	430	400	367

※1 行程 50 時，因本體上鎖式固定孔會被滑座遮住，僅能使用 4 支螺絲固定，建議客戶本體使用下鎖式固定孔鎖附。When the stroke is 50mm, if fixing the body from the top to the bottom, the fixing hole will be blocked by slider and only can be uses 4 screws to fix, as a result, suggest that fixing actuator body from the bottom to the top.

應用例
Application

一般 / 螺桿仕様
GLTH

一般 / 皮帶仕様
ETB / M

無塵 / 螺桿仕様
GCH / ECH

無塵 / 皮帶仕様
ECB

直交連結
XYGT / XTH / XYTB

參考資料
Reference

GLCH Series

GLTH3

GLTH5

GLTH8

GLTH12

GLTH5D

GLTH8D

GLMH5

GLMH8

GLTH5M

GLTH8M

精度
±0.005 mm



最大行程
Maximum Stroke 1250mm

最高速度
Maximum Speed 1440mm/s

馬達容量
Motor Output 200W

最大可搬重量
Max Payload 80kg

型號表示方式 Ordering Method

GLTH8 - L6 - 100 - BC - M20B - C4N5 - 參照右頁
Refer to the right page - 0001

本體型號
Model

行程^{*1}
Stroke

50-1250mm
50間隔 50 mm Pitch

選配
Options

特注式樣
Customization Order No.

馬達位置
Motor Position

BC	馬達外露 Motor Exposed
BM	馬達下折 Motor Bottom Side
BL	馬達左折 Motor Left Side
BR	馬達右折 Motor Right Side

馬達廠牌、功率
Motor Brand、Power Output

M	三菱 Mitsubishi	05	-	B ^{*2}
P	松下 Panasonic	10	-	
Y	安川 Yaskawa	20	200W	
T	台達 Delta	40	-	

原點感應器
Home Sensor

外掛型 Out Side	
C	馬達側 Motor Side
D	反馬達側 Opposite Motor Side
無 SENSOR No Sensor	
E	無 SENSOR No Sensor

端點極限感應器
Limit Sensor

外掛型 Out Side	
3	1只 1 Pc
4	2只 2 Pcs
6	3只 3 Pcs
7	4只 4 Pcs
8	5只 5 Pcs
9	6只 6 Pcs
無 SENSOR No Sensor	
5	無 SENSOR No Sensor

輸出方式&線長
Output type & Cable length

N5	NPN+5米線 NPN+5M Cable
P2	PNP+2米線 PNP+2M Cable
P5	PNP+5米線 PNP+5M Cable
-	NPN+2米線 NPN+2M Cable

*1 選擇行程50時，光電使用有以下限制：When the stroke is 50mm, the sensor installation has the following restrictions:

馬達方向 BC/BM：1.原點與極限需放置於不同側。2.滑座左右兩側皆需安裝感應片。Motor Direction BC/BM 1.Home sensor and limit sensor has to be installed on the different side of body. 2.Both sides of slider need to install the sensor trigger device.

馬達方向 BL/BR：1.原點+極限感應器最數量最多2只(僅能選用C3/D3/E3/E4/E5)。Motor Direction BL/BR 1.Home + limit sensors is 2 maximum (only C3/D3/E3/E4/E5 can be selected)

*2 馬達若無煞車則不表示。If Motor No Brake, No Description.

基本仕様 Specification

性能	位置重複精度 Repeatability	mm	±0.005			
	螺桿導程 Lead	mm	6	12	24	
	最高轉速 Maximum Rotating speed	rpm	3600	3600	3600	
	最高速度 Maximum linear speed ^{※1}	mm/s	360	720	1440	
	最大可搬重量 ^{※2} Maximum Payload	水平使用 Horizontal	kg	80	60	40
		垂直使用 Vertical	kg	15	8	5
	定格推力 Rated Thrust	N	569	284	142	
	標準行程 Stroke (increments)	mm	50-1250mm / 50 間隔 (50 increments)			
	最大加速度 Maximum acceleration	G	0.37	0.73	1.47	
	滾珠螺桿 Ball screw	基本動額定負荷 Basic dynamic load rating Ca	N	7733	5855	3007
基本靜額定負荷 Basic static load rating Coa		N	14200	10401	5414	
直線滑軌 Linear Guide	動態水平負載 Dynamic horizontal (100km)	N	18601			
	靜態水平負載 Static Horizontal	N	34189			
固定側軸承 Fixed bearing	基本動額定負荷 Basic dynamic load rating Cr	N	8447			
	靜態容許負荷 Static load rating Cor	N	5060			
部品	AC 伺服馬達容量 AC Servo Motor Output	W	200			
	滾珠螺桿外徑 Ball Screw Ø	mm	C7Ø14			
	連軸器 Coupling	mm	10X14 /11 ^{※3}			
	原點感應器 Home Sensor	外掛 Outside	T64N2 (NPN+2 米線) (NPN+2M Cable)			

※1 長行程時，會產生螺桿偏擺，需將速度調降 (線速度請參閱尺寸圖下方表格)

During in a long stroke, it causes ballscrew deflection, the speed must reduce. (Please refer to the linear velocity from the data sheet below the dimension graph.)

※2 由於各廠牌的馬達性能不同，需適度搭配回升電阻以達到此荷重條件。

Since the motor performance of each brand is different, a regenerative resistor needs to be appropriately matched to achieve this load condition.

※3 使用 Panasonic 200W 馬達時，馬達軸心為 Ø11；其他廠牌，馬達軸心為 Ø14。Motor (200W) Shaft Diameter: Panasonic: 11mm; Other: 14mm.

容許負載力距表 Allowable Overhang

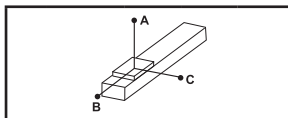

(單位 Unit: mm)

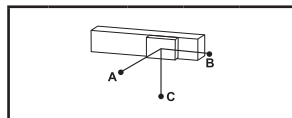

(單位 Unit: mm)

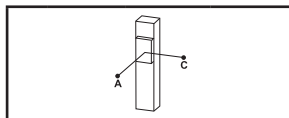

(單位 Unit: mm)

水平安裝 Horizontal Installation		A	B	C
導程 6 Lead	35kg	1600	139	220
	45kg	1210	102	160
	80kg	620	46	74
導程 12 Lead	10kg	2040	470	645
	30kg	638	141	193
	60kg	283	58	80
導程 24 Lead	20kg	253	145	133
	40kg	109	60	55
	-	-	-	-

壁掛安裝 Wall Installation		A	B	C
導程 6 Lead	35kg	220	139	1600
	45kg	160	102	1210
	80kg	74	46	620
導程 12 Lead	10kg	645	470	2040
	30kg	193	141	638
	60kg	80	58	283
導程 24 Lead	20kg	133	145	253
	40kg	55	60	109
	-	-	-	-

垂直安裝 Vertical Installation		A	C
導程 6 Lead	10kg	535	535
	15kg	360	360
	-	-	-
導程 12 Lead	3.5kg	1380	1380
	8kg	605	605
	-	-	-
導程 24 Lead	2kg	1380	1380
	5kg	556	556
	-	-	-

靜額定扭矩 Static Loading Moment

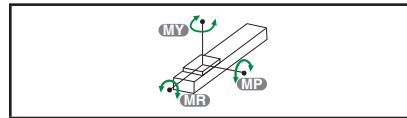

(單位 Unit: N.m)

MY	137
MP	137
MR	227

* 力矩表所表示的數據，代表荷重的重心位置於單一向容許懸出的長度。
The data represented by the moment table is the center of gravity of the load. The length of the overhang is allowed in a single direction.
* 符合型錄規範的正常使用下，保證壽命為 10000 公里。
Operation life is 10,000km when the product is using under the specified conditions.
* 倒吊使用無法套用標準規範，如有需求請洽詢我司業務。
Data information is not for ceiling-mount inverse use. Contact us for the details if you want to apply ceiling-mount inverse usage.
* 壽命及力矩是以馬達加減速設定 0.2 秒計算。
The life and torque are calculated by setting the motor acceleration and deceleration for 0.2 seconds.

選配 Options

MM

指定馬達出線方向 Selectable Cable Leading Direction		
代號 Code	說明 Instructions	需參照 Refer to
MW	朝上 Upper side	P.111 ~ P.112
MM	朝下 Bottom side	
ML	朝左 Left side	
MR	朝右 Right side	

CMK

馬達傳動配件追加鍵槽 Additional keyway for motor drive parts				
代號 Code	說明 Instructions			需參照 Refer to
	追加鍵槽 Keyway Groove	馬達位置 Motor Position	出貨型式 Shipment Type	
CMK	單邊 (限定馬達側) Single (Limited to the motor side)	BC	鍵槽式聯軸器 Keyway Coupling	P.113 ~ P.115
		BL/BR/BM	鍵槽式皮帶輪 Keyway Belt Pulley	
SKY	雙邊 Double	BC	鍵槽式聯軸器 Keyway Coupling	
		BL/BR/BM	鍵槽式皮帶輪 Keyway Belt Pulley	
SKN	雙邊 Double	BC	無聯軸器 (請自行購買安裝) Without Coupling (Please purchase and install by yourself)	
		BL/BR/BM	無馬達端皮帶輪 (請自行購買安裝) Without Belt Pulley (Please purchase and install by yourself)	

GLTH Series

- GLTH3
- GLTH5
- GLTH8
- GLTH12
- GLTH5D
- GLTH8D
- GLMH5
- GLMH8
- GLTH5M
- GLTH8M



Download at www.toyorobot.com

BC 馬達外露 Motor Exposed

單位 Unit : mm

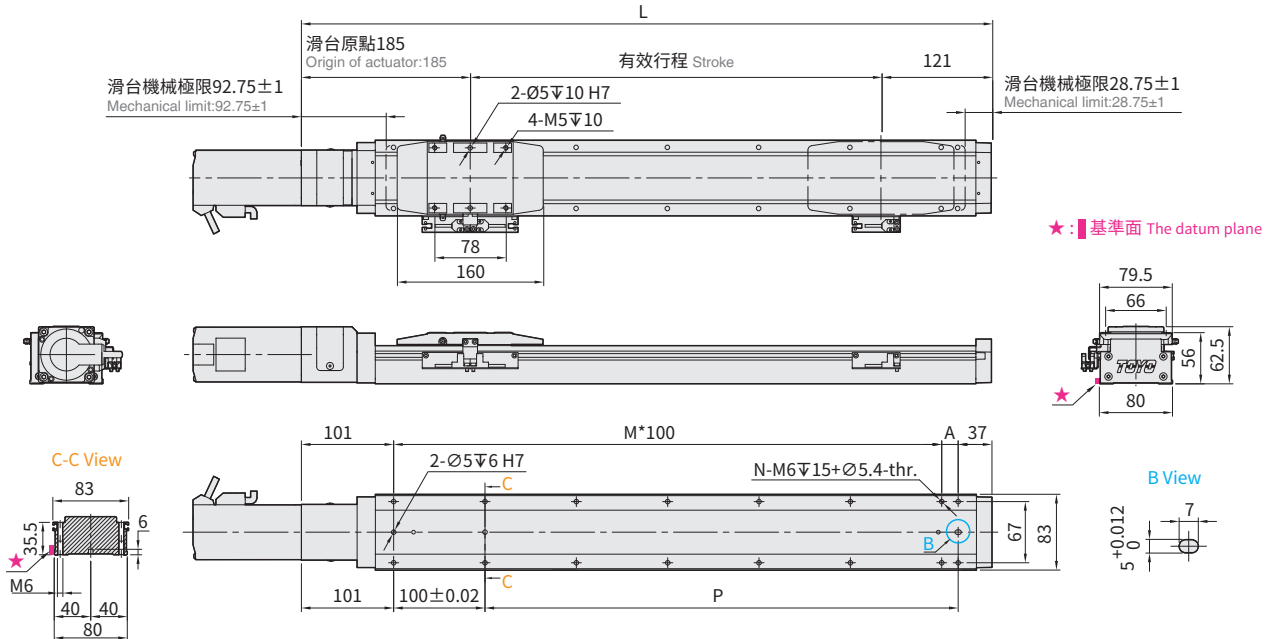

BM 馬達下折 Motor Bottom Side

單位 Unit : mm

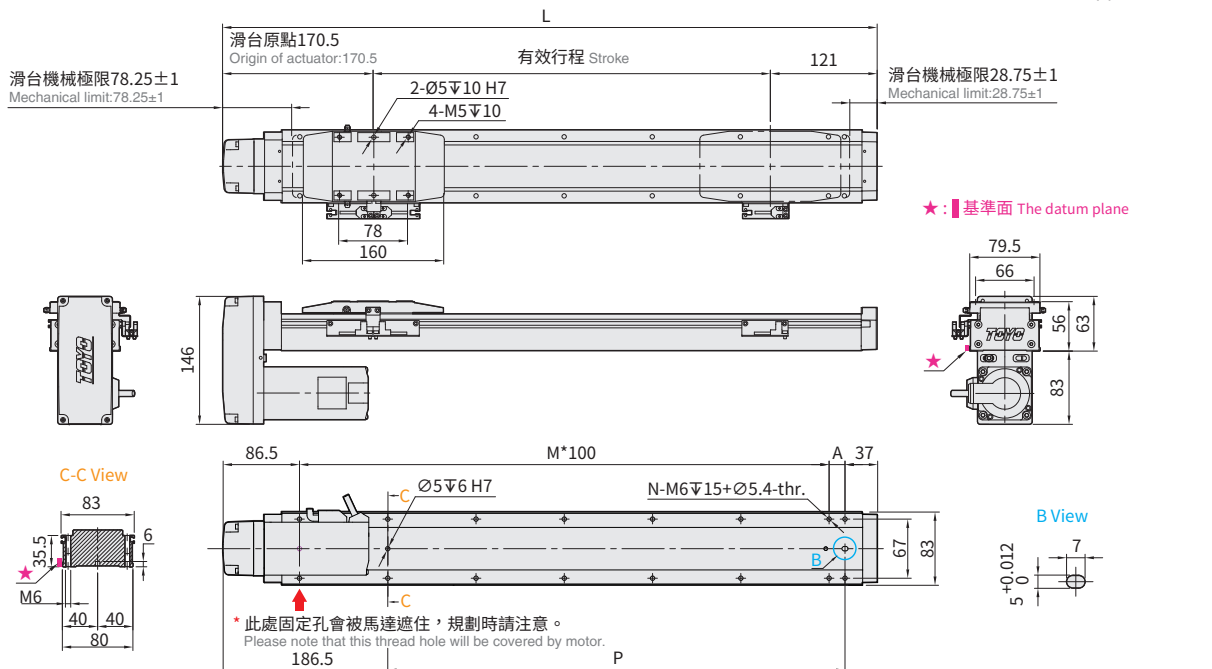

有效行程 Stroke	50 ⁻¹	100	150	200	250	300	350	400	450	500	550	600	650	700	750	800	850	900	950	1000	1050	1100	1150	1200	1250	
極限行程 Limit Stroke (±1)	74.5	124.5	174.5	224.5	274.5	324.5	374.5	424.5	474.5	524.5	574.5	624.5	674.5	724.5	774.5	824.5	874.5	924.5	974.5	1024.5	1074.5	1124.5	1174.5	1224.5	1274.5	
L	BC	356	406	456	506	556	606	656	706	756	806	856	906	956	1006	1056	1106	1156	1206	1256	1306	1356	1406	1456	1506	1556
	BM	341.5	391.5	441.5	491.5	541.5	591.5	641.5	691.5	741.5	791.5	841.5	891.5	941.5	991.5	1041.5	1091.5	1141.5	1191.5	1241.5	1291.5	1341.5	1391.5	1441.5	1491.5	1541.5
A	18	68	18	68	18	68	18	68	18	68	18	68	18	68	18	68	18	68	18	68	18	68	18	68	18	68
M	2	2	3	3	4	4	5	5	6	6	7	7	8	8	9	9	10	10	11	11	12	12	13	13	14	14
N	8	8	10	10	12	12	14	14	16	16	18	18	20	20	22	22	24	24	26	26	28	28	30	30	32	32
P	118	168	218	268	318	368	418	468	518	568	618	668	718	768	818	868	918	968	1018	1068	1118	1168	1218	1268	1318	1318
KG	BC	2.31	2.61	2.9	3.2	3.49	3.79	4.09	4.38	4.68	4.97	5.27	5.57	5.87	6.16	6.46	6.75	7.05	7.35	7.64	7.94	8.24	8.53	8.83	9.13	9.42
	BM	2.68	2.98	3.27	3.57	3.87	4.16	4.46	4.75	5.05	5.35	5.64	5.94	6.24	6.53	6.83	7.13	7.42	7.72	8.01	8.31	8.61	8.9	9.2	9.5	9.79
線速度 Linear Speed mm/s	導程 Lead 6	360										350	310	270	240	210	190	170	160	140	130	120	110	100	90	
	導程 Lead 12	720										700	620	540	480	420	380	340	320	280	260	240	220	200	180	
	導程 Lead 24	1440										1400	1240	1080	960	840	760	680	640	560	520	480	440	400	360	

* 1 行程 50 時，因本體上鎖式固定孔會被滑座遮住，僅能使用 4 支螺絲固定，建議客戶本體使用下鎖式固定孔鎖附。 When the stroke is 50mm, if fixing the body from the top to the bottom, the fixing hole will be blocked by slider and only can be uses 4 screws to fix; as a result, suggest that fixing actuator body from the bottom to the top.



Download at www.toyorobot.com

BL 馬達左折 Motor Left Side

單位 Unit : mm

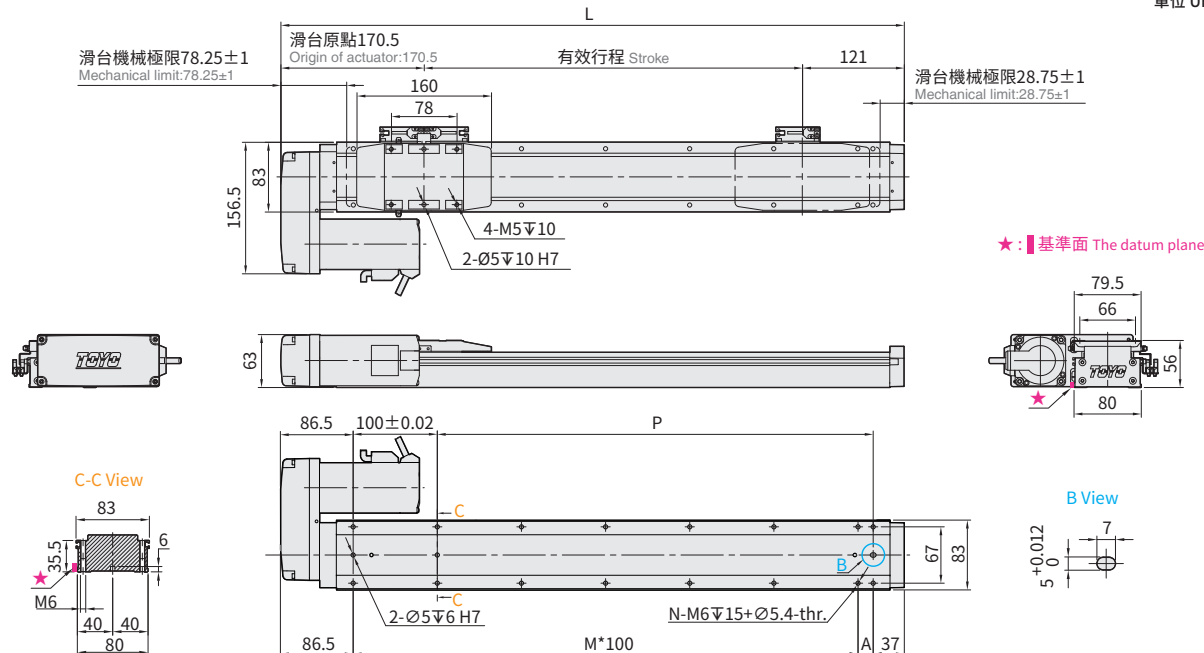

BR 馬達右折 Motor Right Side

單位 Unit : mm

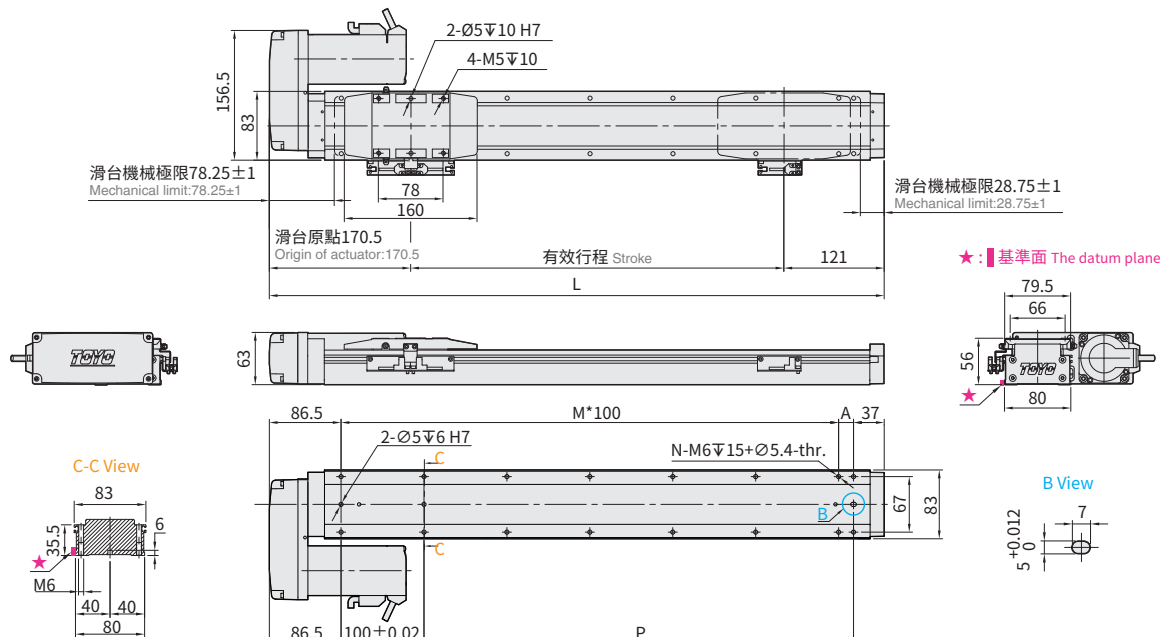

有效行程 Stroke	50 ⁻¹	100	150	200	250	300	350	400	450	500	550	600	650	700	750	800	850	900	950	1000	1050	1100	1150	1200	1250	
極限行程 Limit Stroke (±1)	74.5	124.5	174.5	224.5	274.5	324.5	374.5	424.5	474.5	524.5	574.5	624.5	674.5	724.5	774.5	824.5	874.5	924.5	974.5	1024.5	1074.5	1124.5	1174.5	1224.5	1274.5	
L	341.5	391.5	441.5	491.5	541.5	591.5	641.5	691.5	741.5	791.5	841.5	891.5	941.5	991.5	1041.5	1091.5	1141.5	1191.5	1241.5	1291.5	1341.5	1391.5	1441.5	1491.5	1541.5	
A	18	68	18	68	18	68	18	68	18	68	18	68	18	68	18	68	18	68	18	68	18	68	18	68	18	
M	2	2	3	3	4	4	5	5	6	6	7	7	8	8	9	9	10	10	11	11	12	12	13	13	14	
N	8	8	10	10	12	12	14	14	16	16	18	18	20	20	22	22	24	24	26	26	28	28	30	30	32	
P	118	168	218	268	318	368	418	468	518	568	618	668	718	768	818	868	918	968	1018	1068	1118	1168	1218	1268	1318	
KG	2.68	2.98	3.27	3.57	3.87	4.16	4.46	4.75	5.05	5.35	5.64	5.94	6.24	6.53	6.83	7.13	7.42	7.72	8.01	8.31	8.61	8.9	9.2	9.5	9.79	
線速度 Linear Speed mm/s	導程 Lead 6	360											350	310	270	240	210	190	170	160	140	130	120	110	100	90
	導程 Lead 12	720											700	620	540	480	420	380	340	320	280	260	240	220	200	180
	導程 Lead 24	1440											1400	1240	1080	960	840	760	680	640	560	520	480	440	400	360

*1 行程 50 時，因本體上鎖式固定孔會被滑座遮住，僅能使用 4 支螺絲固定，建議客戶本體使用下鎖式固定孔鎖附。When the stroke is 50mm, if fixing the body from the top to the bottom, the fixing hole will be blocked by slider and only can be uses 4 screws to fix; as a result, suggest that fixing actuator body from the bottom to the top.

應用例
Application

一般 / 螺桿仕様
GLTH

一般 / 皮帶仕様
ETB / M

無塵 / 螺桿仕様
GCH / ECH

無塵 / 皮帶仕様
ECB

直交連結
XYGT / XYTH / XYTB

參考資料
Reference

GLTH Series

GLTH3

GLTH5

GLTH8

GLTH12

GLTH5D

GLTH8D

GLMH5

GLMH8

GLTH5M

GLTH8M

精度
±0.005 mm



最大行程
Maximum Stroke 1250mm

最高速度
Maximum Speed 1440mm/s

馬達容量
Motor Output 400W

最大可搬重量
Max Payload 105kg

型號表示方式 Ordering Method

GLTH8 - L6 - 100 - BC - M40B - C4N5 - 參照右頁
Refer to the right page - 0001

本體型號
Model

行程^{*1}
Stroke

50-1250mm
50間隔 50 mm Pitch

選配
Options

特注式樣
Customization Order No.

馬達位置
Motor Position

BC	馬達外露 Motor Exposed
BM	馬達下折 Motor Bottom Side
BL	馬達左折 Motor Left Side
BR	馬達右折 Motor Right Side

馬達廠牌、功率
Motor Brand · Power Output

M	三菱 Mitsubishi	05	-	B ^{*2}
P	松下 Panasonic	10	-	
Y	安川 Yaskawa	20	-	
T	台達 Delta	40	400W	

原點感應器
Home Sensor

外掛型 Out Side	
C	馬達側 Motor Side
D	反馬達側 Opposite Motor Side
無 SENSOR No Sensor	
E	無 SENSOR No Sensor

端點極限感應器
Limit Sensor

外掛型 Out Side	
3	1只 1 Pc
4	2只 2 Pcs
6	3只 3 Pcs
7	4只 4 Pcs
8	5只 5 Pcs
9	6只 6 Pcs
無 SENSOR No Sensor	
5	無 SENSOR No Sensor

輸出方式&線長
Output type & Cable length

N5	NPN+5米線 NPN+5M Cable
P2	PNP+2米線 PNP+2M Cable
P5	PNP+5米線 PNP+5M Cable
-	NPN+2米線 NPN+2M Cable

螺桿導程
Ball Screw Lead

6	6mm
12	12mm
24	24mm

*1 選擇行程50時，光電使用有以下限制：When the stroke is 50mm, the sensor installation has the following restrictions:

馬達方向 BC/BM：1.原點與極限需放置於不同側。2.滑座左右兩側皆需安裝感應片。Motor Direction BC/BM 1.Home sensor and limit sensor has to be installed on the different side of body. 2.Both sides of slider need to install the sensor trigger device.

馬達方向 BL/BR：1.原點+極限感應器最數量最多2只 (僅能選用C3/D3/E3/E4/E5)。Motor Direction BL/BR 1.Home + limit sensors is 2 maximum (only C3/D3/E3/E4/E5 can be selected)

*2 馬達若無煞車則不表示。If Motor No Brake, No Description.

基本仕様 Specification

性能	位置重複精度 Repeatability	mm	±0.005			
	螺桿導程 Lead	mm	6	12	24	
	最高轉速 Maximum Rotating speed	rpm	3600	3600	3600	
	最高速度 Maximum linear speed ※1	mm/s	360	720	1440	
	最大可搬重量 Maximum Payload	水平使用 Horizontal	kg	105	85	40
		垂直使用 Vertical	kg	30	20	10
	定格推力 Rated Thrust	N	1156	578	289	
	標準行程 Stroke (increments)	mm	50-1250mm / 50 間隔 (50 increments)			
	最大加速度 Maximum acceleration	G	0.37	0.73	1.47	
	滾珠螺桿 Ball screw	基本動額定負荷 Basic dynamic load rating Ca	N	7733	5855	3007
基本靜額定負荷 Basic static load rating Coa		N	14200	10401	5414	
直線滑軌 Linear Guide	動態水平負載 Dynamic horizontal (100km)	N	18601			
	靜態水平負載 Static Horizontal	N	34189			
固定側軸承 Fixed bearing	基本動額定負荷 Basic dynamic load rating Cr	N	8447			
	靜態容許負荷 Static load rating Cor	N	5060			
部品	AC 伺服馬達容量 AC Servo Motor Output	W	400			
	滾珠螺桿外徑 Ball Screw Ø	mm	C7Ø14			
	連軸器 Coupling	mm	10X14			
	原點感應器 Home Sensor	外掛 Outside	T64N2 (NPN+2 米線) (NPN+2M Cable)			

※1 長行程時，會產生螺桿偏擺，需將速度調降 (線速度請參閱尺寸圖下方表格)
During in a long stroke, it causes ballscrew deflection, the speed must reduce. (Please refer to the linear velocity from the data sheet below the dimension graph.)

容許負載力距表 Allowable Overhang

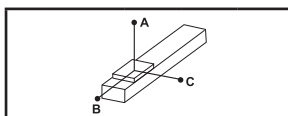

(單位 Unit : mm)

水平安裝 Horizontal Installation	A	B	C
導程 6 Lead	30kg	1900	261
	50kg	1080	88
	105kg	434	29
導程 12 Lead	25kg	780	175
	35kg	530	117
	85kg	175	33
導程 24 Lead	4kg	1400	820
	12kg	440	257
	40kg	109	60

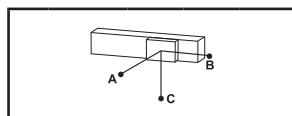

(單位 Unit : mm)

壁掛安裝 Wall Installation	A	B	C
導程 6 Lead	30kg	261	165
	50kg	140	88
	105kg	47	29
導程 12 Lead	25kg	240	175
	35kg	160	117
	85kg	46	33
導程 24 Lead	4kg	750	820
	12kg	235	257
	40kg	55	109

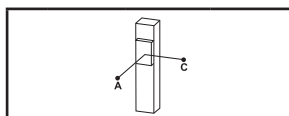

(單位 Unit : mm)

垂直安裝 Vertical Installation	A	C
導程 6 Lead	16kg	335
	30kg	180
	-	-
導程 12 Lead	12kg	400
	20kg	240
	-	-
導程 24 Lead	6kg	460
	10kg	275
	-	-

靜額定扭矩 Static Loading Moment

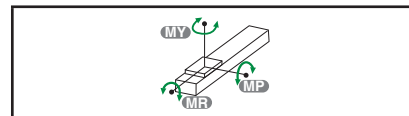

(單位 Unit : N.m)

MY	137
MP	137
MR	227

* 力矩表所表示的數據，代表荷重的重心位置於單一方向容許懸出的長度。
The data represented by the moment table is the center of gravity of the load. The length of the overhang is allowed in a single direction.
* 符合型錄規範的正常使用下，保證壽命為 10000 公里。
Operation life is 10,000km when the product is using under the specified conditions.
* 倒吊使用無法套用標準規範，如有需求請洽詢我司業務。
Data information is not for ceiling-mount inverse use. Contact us for the details if you want to apply ceiling-mount inverse usage.
* 壽命及力矩是以馬達加減速設定 0.2 秒計算。
The life and torque are calculated by setting the motor acceleration and deceleration for 0.2 seconds.

選配 Options

MM

指定馬達出線方向 Selectable Cable Leading Direction		
代號 Code	說明 Instructions	需參照 Refer to
MW	朝上 Upper side	P.111 ~ P.112
MM	朝下 Bottom side	
ML	朝左 Left side	
MR	朝右 Right side	

CMK

馬達傳動配件追加鍵槽 Additional keyway for motor drive parts				
代號 Code	說明 Instructions			需參照 Refer to
	追加鍵槽 Keyway Groove	馬達位置 Motor Position	出貨型式 Shipment Type	
CMK	單邊 (限定馬達側) Single (Limited to the motor side)	BC	鍵槽式聯軸器 Keyway Coupling	P.113 ~ P.115
		BL/BR/BM	鍵槽式皮帶輪 Keyway Belt Pulley	
SKY	雙邊 Double	BC	鍵槽式聯軸器 Keyway Coupling	
		BL/BR/BM	鍵槽式皮帶輪 Keyway Belt Pulley	
SKN	雙邊 Double	BC	無聯軸器 (請自行購買安裝) Without Coupling (Please purchase and install by yourself)	
		BL/BR/BM	無馬達端皮帶輪 (請自行購買安裝) Without Belt Pulley (Please purchase and install by yourself)	

GLTH Series

- GLTH3
- GLTH5
- GLTH8
- GLTH12
- GLTH5D
- GLTH8D
- GLMH5
- GLMH8
- GLTH5M
- GLTH8M

GLTH8 單軸 /1-axis

▶ 軌道內嵌
Integrated Linear Bearing

▶ 螺桿驅動
Ball Screw Drive



• Download at www.toyorobot.com •

BC 馬達外露 Motor Exposed

單位 Unit : mm

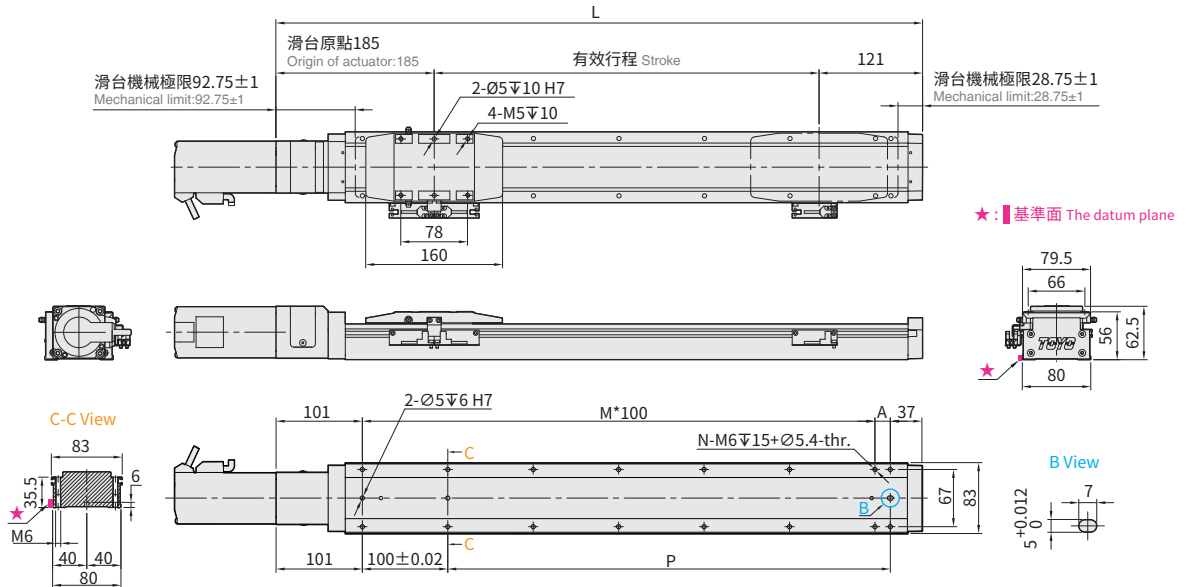

BM 馬達下折 Motor Bottom Side

單位 Unit : mm

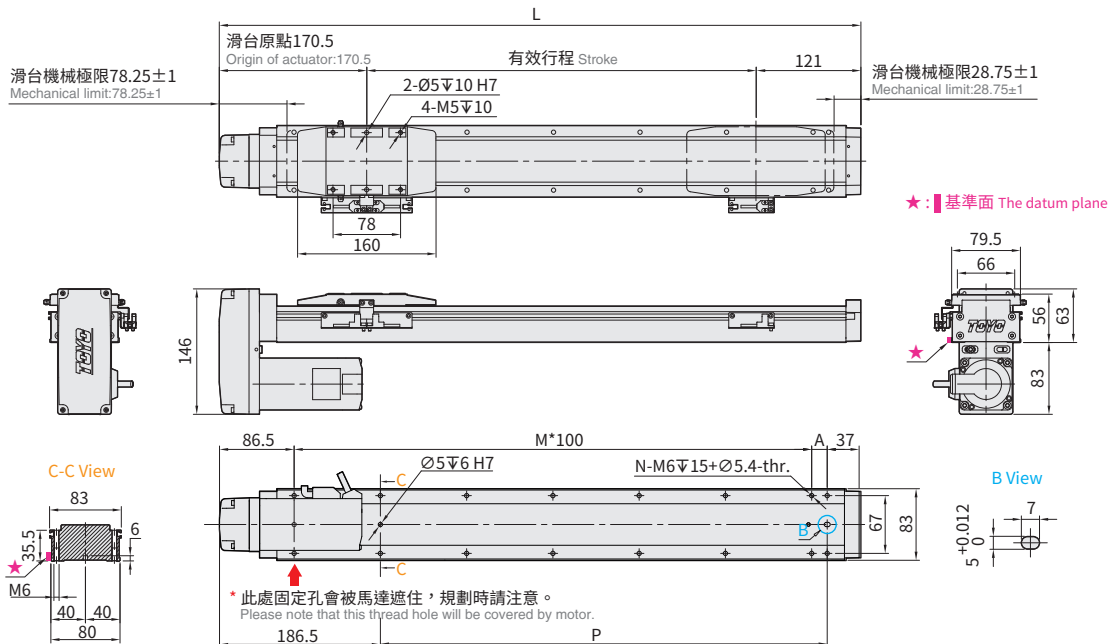

有效行程 Stroke	50 ⁻¹	100	150	200	250	300	350	400	450	500	550	600	650	700	750	800	850	900	950	1000	1050	1100	1150	1200	1250	
極限行程 Limit Stroke (±1)	74.5	124.5	174.5	224.5	274.5	324.5	374.5	424.5	474.5	524.5	574.5	624.5	674.5	724.5	774.5	824.5	874.5	924.5	974.5	1024.5	1074.5	1124.5	1174.5	1224.5	1274.5	
L	BC	356	406	456	506	556	606	656	706	756	806	856	906	956	1006	1056	1106	1156	1206	1256	1306	1356	1406	1456	1506	1556
	BM	341.5	391.5	441.5	491.5	541.5	591.5	641.5	691.5	741.5	791.5	841.5	891.5	941.5	991.5	1041.5	1091.5	1141.5	1191.5	1241.5	1291.5	1341.5	1391.5	1441.5	1491.5	1541.5
A	18	68	18	68	18	68	18	68	18	68	18	68	18	68	18	68	18	68	18	68	18	68	18	68	18	68
M	2	2	3	3	4	4	5	5	6	6	7	7	8	8	9	9	10	10	11	11	12	12	13	13	14	
N	8	8	10	10	12	12	14	14	16	16	18	18	20	20	22	22	24	24	26	26	28	28	30	30	32	
P	118	168	218	268	318	368	418	468	518	568	618	668	718	768	818	868	918	968	1018	1068	1118	1168	1218	1268	1318	
KG	BC	2.31	2.61	2.9	3.2	3.49	3.79	4.09	4.38	4.68	4.97	5.27	5.57	5.87	6.16	6.46	6.75	7.05	7.35	7.64	7.94	8.24	8.53	8.83	9.13	9.42
	BM	2.68	2.98	3.27	3.57	3.87	4.16	4.46	4.75	5.05	5.35	5.64	5.94	6.24	6.53	6.83	7.13	7.42	7.72	8.01	8.31	8.61	8.9	9.2	9.5	9.79
線速度 Linear Speed mm/s	導程 Lead 6											360														
	導程 Lead 12											720														
	導程 Lead 24											1440														
												350	310	270	240	210	190	170	160	140	130	120	110	100	90	
												700	620	540	480	420	380	340	320	280	260	240	220	200	180	
												1400	1240	1080	960	840	760	680	640	560	520	480	440	400	360	

※1 行程 50 時，因本體上鎖式固定孔會被滑座遮住，僅能使用 4 支螺絲固定，建議客戶本體使用下鎖式固定孔鎖附。When the stroke is 50mm, if fixing the body from the top to the bottom, the fixing hole will be blocked by slider and only can be uses 4 screws to fix;as a result, suggest that fixing actuator body from the bottom to the top.



Download at www.toyorobot.com

BL 馬達左折 Motor Left Side

單位 Unit : mm

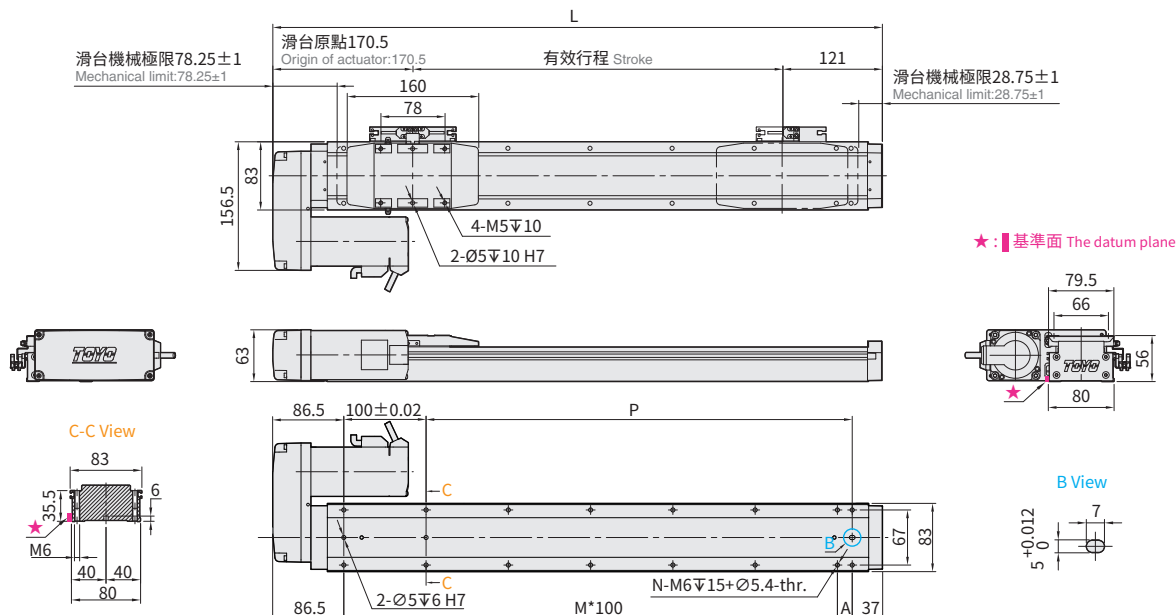

BR 馬達右折 Motor Right Side

單位 Unit : mm

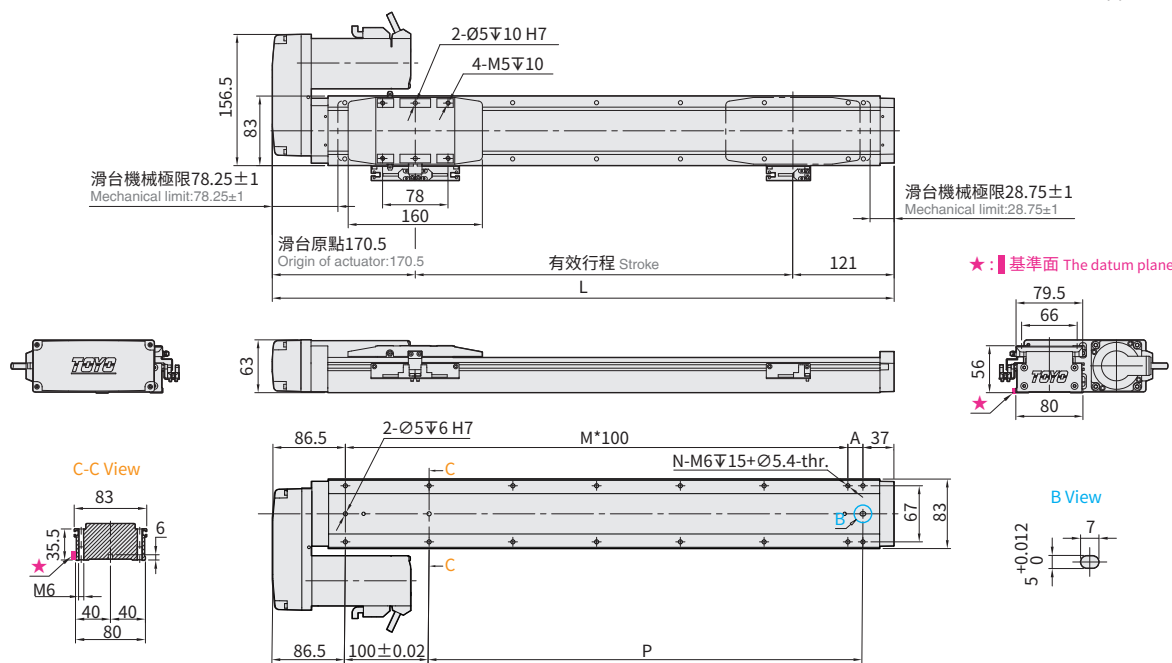

有效行程 Stroke	50 ⁻¹	100	150	200	250	300	350	400	450	500	550	600	650	700	750	800	850	900	950	1000	1050	1100	1150	1200	1250
極限行程 Limit Stroke (±1)	74.5	124.5	174.5	224.5	274.5	324.5	374.5	424.5	474.5	524.5	574.5	624.5	674.5	724.5	774.5	824.5	874.5	924.5	974.5	1024.5	1074.5	1124.5	1174.5	1224.5	1274.5
L	341.5	391.5	441.5	491.5	541.5	591.5	641.5	691.5	741.5	791.5	841.5	891.5	941.5	991.5	1041.5	1091.5	1141.5	1191.5	1241.5	1291.5	1341.5	1391.5	1441.5	1491.5	1541.5
A	18	68	18	68	18	68	18	68	18	68	18	68	18	68	18	68	18	68	18	68	18	68	18	68	18
M	2	2	3	3	4	4	5	5	6	6	7	7	8	8	9	9	10	10	11	11	12	12	13	13	14
N	8	8	10	10	12	12	14	14	16	16	18	18	20	20	22	22	24	24	26	26	28	28	30	30	32
P	118	168	218	268	318	368	418	468	518	568	618	668	718	768	818	868	918	968	1018	1068	1118	1168	1218	1268	1318
KG	2.68	2.98	3.27	3.57	3.87	4.16	4.46	4.75	5.05	5.35	5.64	5.94	6.24	6.53	6.83	7.13	7.42	7.72	8.01	8.31	8.61	8.9	9.2	9.5	9.79
線速度 Linear Speed mm/s	導程 Lead 6	360																							
	導程 Lead 12	720																							
	導程 Lead 24	1440																							

※1行程50時，因本體上鎖式固定孔會被滑座遮住，僅能使用4支螺絲固定，建議客戶本體使用下鎖式固定孔鎖附。When the stroke is 50mm, if fixing the body from the top to the bottom, the fixing hole will be blocked by slider and only can be uses 4 screws to fix;as a result, suggest that fixing actuator body from the bottom to the top.

應用例
Application

一般 / 螺桿仕様
GLTH

一般 / 皮帶仕様
ETB / M

無塵 / 螺桿仕様
GCH / ECH

無塵 / 皮帶仕様
ECB

直交連結
XYGT / XTH / XYTB

參考資料
Reference

GLTH Series

GLTH3

GLTH5

GLTH8

GLTH12

GLTH5D

GLTH8D

GLMH5

GLMH8

GLTH5M

GLTH8M

GLTH12 單軸 /1-axis

▶ 軌道內嵌
Integrated Linear Bearing

▶ 螺桿驅動
Ball Screw Drive

精度
±0.005 mm



此圖僅供參考，出貨規格詳見尺寸圖面
The picture is just for the reference. Please check the the actual dimensions on the drawing.

最大行程
Maximum Stroke 1250mm

最高速度
Maximum Speed 1440mm/s

馬達容量
Motor Output 400W

最大可搬重量
Max Payload 110kg

型號表示方式 Ordering Method

GLTH12-L12-100-BC-M40B-C4N5- 參照右頁
Refer to the right page. -0001

本體型號
Model

行程¹
Stroke

50-1250mm
50間隔 50 mm Pitch

選配
Options

特注式樣
Customization Order No.

螺桿導程
Ball Screw Lead

6	6mm
12	12mm
24	24mm

馬達位置
Motor Position

BC	馬達外露 Motor Exposed
BM	馬達下折 Motor Bottom Side
BL	馬達左折 Motor Left Side
BR	馬達右折 Motor Right Side

馬達廠牌、功率
Motor Brand + Power Output

M	三菱 Mitsubishi	05	-	B ²
P	松下 Panasonic	10	-	
Y	安川 Yaskawa	20	-	
T	台達 Delta	40	400W	

原點感應器
Home Sensor

外掛型 Out Side	
C	馬達側 Motor Side
D	反馬達側 Opposite Motor Side
	無 SENSOR No Sensor
E	無 SENSOR No Sensor

端點極限感應器
Limit Sensor

外掛型 Out Side	
3	1只 1 Pc
4	2只 2 Pcs
6	3只 3 Pcs
7	4只 4 Pcs
8	5只 5 Pcs
9	6只 6 Pcs
	無 SENSOR No Sensor
5	無 SENSOR No Sensor

輸出方式&線長
Output type & Cable length

N5	NPN+5米線 NPN+5M Cable
P2	PNP+2米線 PNP+2M Cable
P5	PNP+5米線 PNP+5M Cable
-	NPN+2米線 NPN+2M Cable

¹ 選擇行程50時，光電使用有以下限制：When the stroke is 50mm, the sensor installation has the following restrictions:

馬達方向 BC/BM：1.原點與極限需放置於不同側。2.滑座左右兩側皆需安裝感應片。Motor Direction BC/BM 1.Home sensor and limit sensor has to be installed on the different side of body. 2.Both sides of slider need to install the sensor trigger device.

馬達方向 BL/BR：1.原點+極限感應器最數量最多2只(僅能選用C3/D3/E3/E4/E5)。Motor Direction BL/BR 1.Home + limit sensors is 2 maximum (only C3/D3/E3/E4/E5 can be selected)

² 馬達若無煞車則不表示。If Motor No Brake, No Description.

基本仕様 Specification

性能	位置重複精度 Repeatability	mm	±0.005			
	螺桿導程 Lead	mm	6	12	24	
	最高轉速 Maximum Rotating speed	rpm	3600	3600	3600	
	最高速度 Maximum linear speed ※1	mm/s	360	720	1440	
	最大可搬重量 Maximum Payload	水平使用 Horizontal	kg	110	88	40
		垂直使用 Vertical	kg	30	20	10
	定格推力 Rated Thrust	N	1156	578	289	
	標準行程 Stroke (increments)	mm	50-1250mm / 50 間隔 (50 increments)			
	最大加速度 Maximum acceleration	G	0.37	0.73	1.47	
	滾珠螺桿 Ball screw	基本動額定負荷 Basic dynamic load rating Ca	N	7733	5855	3007
基本靜額定負荷 Basic static load rating Coa		N	14200	10401	5414	
直線滑軌 Linear Guide	動態水平負載 Dynamic horizontal (100km)	N	51128			
	靜態水平負載 Static Horizontal	N	84518			
固定側軸承 Fixed bearing	基本動額定負荷 Basic dynamic load rating Cr	N	8447			
	靜態容許負荷 Static load rating Cor	N	5060			
部品	AC 伺服馬達容量 AC Servo Motor Output	W	400			
	滾珠螺桿外徑 Ball Screw Ø	mm	C7Ø14			
	連軸器 Coupling	mm	10X14			
	原點感應器 Home Sensor	外掛 Outside	T64N2 (NPN+2 米線) (NPN+2M Cable)			

※1 長行程時，會產生螺桿偏擺，需將速度調降 (線速度請參閱尺寸圖下方表格)

During in a long stroke, it causes ballscrew deflection, the speed must reduce. (Please refer to the linear velocity from the data sheet below the dimension graph.)

容許負載力距表 Allowable Overhang

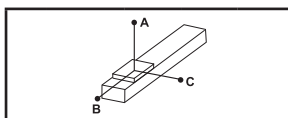

(單位 Unit: mm)

水平安裝 Horizontal Installation	A	B	C
導程 6 Lead	60kg	1900	165 268
	80kg	1428	113 184
	110kg	963	70 114
導程 12 Lead	60kg	1538	346 483
	70kg	1300	290 406
	88kg	1010	222 311
導程 24 Lead	20kg	1285	753 693
	30kg	835	487 450
	40kg	613	355 328

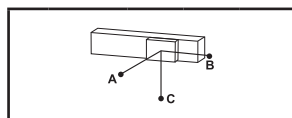

(單位 Unit: mm)

壁掛安裝 Wall Installation	A	B	C
導程 6 Lead	60kg	268	165 1990
	80kg	184	113 1428
	110kg	114	70 963
導程 12 Lead	60kg	483	346 1538
	70kg	406	290 1300
	88kg	311	222 1010
導程 24 Lead	20kg	693	753 1285
	30kg	450	487 835
	40kg	328	355 613

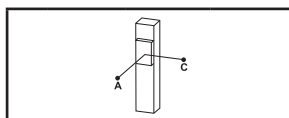

(單位 Unit: mm)

垂直安裝 Vertical Installation	A	C
導程 6 Lead	20kg	1250 1250
	30kg	830 830
	-	- -
導程 12 Lead	10kg	2250 2250
	20kg	1120 1120
	-	- -
導程 24 Lead	7kg	1840 1840
	10kg	1280 1280
	-	- -

靜額定扭矩 Static Loading Moment

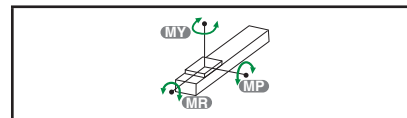

(單位 Unit: N.m)

MY	606
MP	606
MR	1168

* 力矩表所表示的數據，代表荷重的重心位置於單一方向容許懸出的長度。The data represented by the moment table is the center of gravity of the load. The length of the overhang is allowed in a single direction.
 * 符合型錄規範的正常使用下，保證壽命為 10000 公里。Operation life is 10,000km when the product is using under the specified conditions.
 * 倒吊使用無法套用標準規範，如有需求請洽詢我司業務。Data information is not for ceiling-mount inverse use. Contact us for the details if you want to apply ceiling-mount inverse usage.
 * 壽命及力矩是以馬達加速減速設定 0.2 秒計算。The life and torque are calculated by setting the motor acceleration and deceleration for 0.2 seconds.

選配 Options

MM

代號 Code	說明 Instructions	需參照 Refer to
MW	朝上 Upper side	P.111 ~ P.112
MM	朝下 Bottom side	
ML	朝左 Left side	
MR	朝右 Right side	

CMK

代號 Code	馬達傳動配件追加鍵槽 Additional keyway for motor drive parts			需參照 Refer to
	追加鍵槽 Keyway Groove	馬達位置 Motor Position	出貨型式 Shipment Type	
CMK	單邊 (限定馬達側) Single (Limited to the motor side)	BC	鍵槽式聯軸器 Keyway Coupling	P.113 ~ P.115
		BL/BR/BM	鍵槽式皮帶輪 Keyway Belt Pulley	
SKY	雙邊 Double	BC	鍵槽式聯軸器 Keyway Coupling	
		BL/BR/BM	鍵槽式皮帶輪 Keyway Belt Pulley	
SKN	雙邊 Double	BC	無聯軸器 (請自行購買安裝) Without Coupling (Please purchase and install by yourself)	
		BL/BR/BM	無馬達端皮帶輪 (請自行購買安裝) Without Belt Pulley (Please purchase and install by yourself)	

GLTH Series

- GLTH3
- GLTH5
- GLTH8
- GLTH12
- GLTH5D
- GLTH8D
- GLMH5
- GLMH8
- GLTH5M
- GLTH8M



Download at www.toyorobot.com

BC 馬達外露 Motor Exposed

單位 Unit : mm

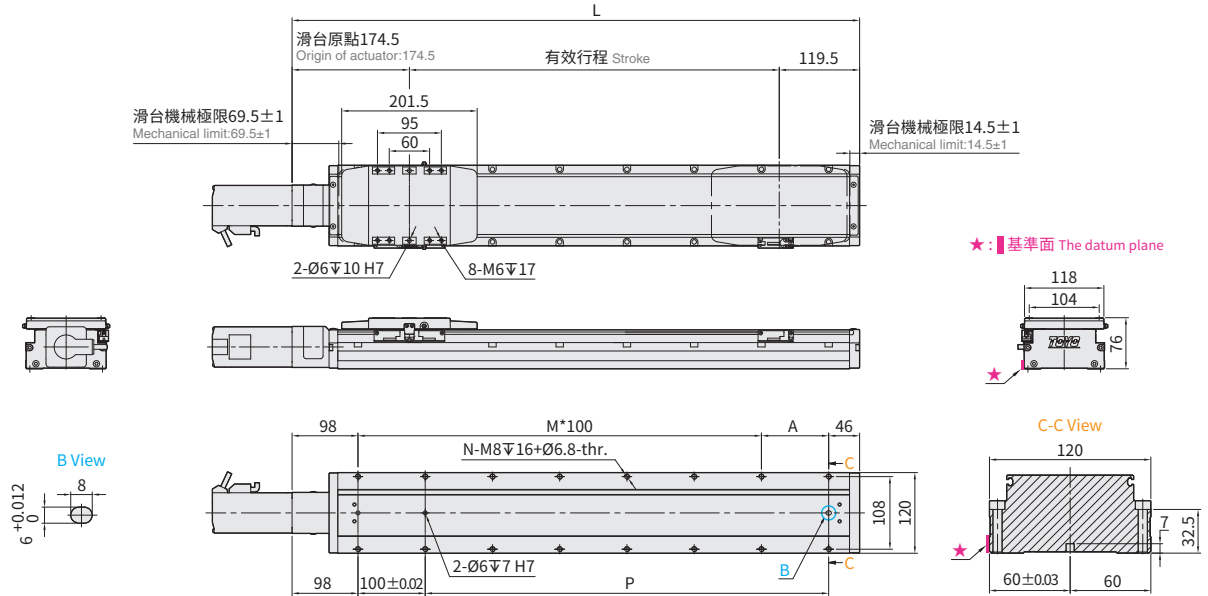

BM 馬達下折 Motor Bottom Side

單位 Unit : mm

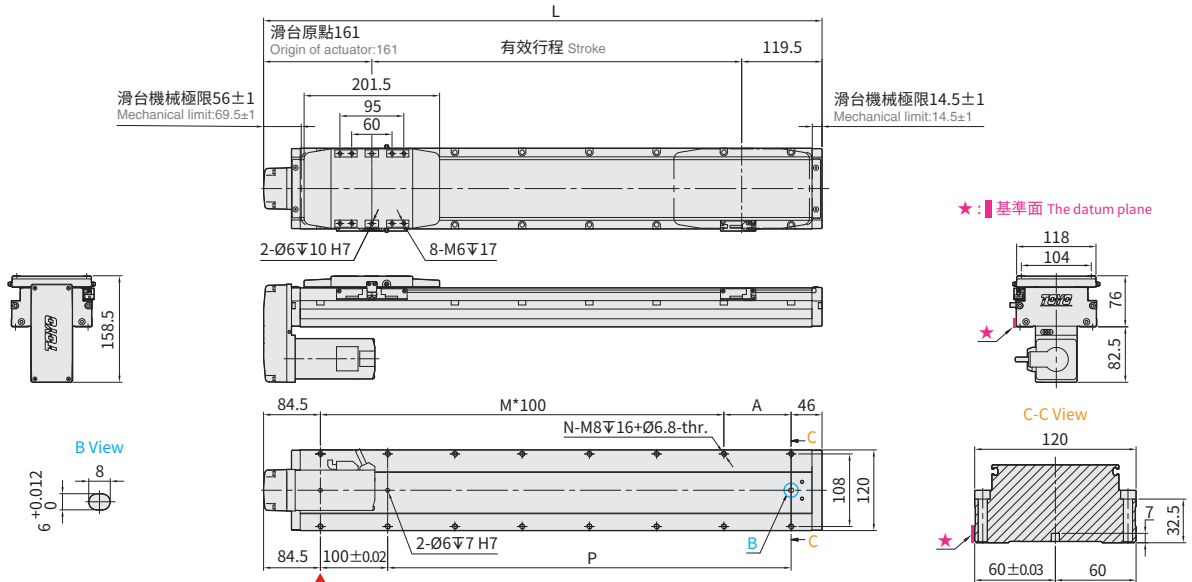

* 此處固定孔會被馬達遮住，規劃時請注意。
Please note that this thread hole will be covered by motor.

有效行程 Stroke	50 ⁻¹	100	150	200	250	300	350	400	450	500	550	600	650	700	750	800	850	900	950	1000	1050	1100	1150	1200	1250		
極限行程 Limit Stroke (±1)	58.5	108.5	158.5	208.5	258.5	308.5	358.5	408.5	458.5	508.5	558.5	608.5	658.5	708.5	758.5	808.5	858.5	908.5	958.5	1008.5	1058.5	1108.5	1158.5	1208.5	1258.5		
L	BC	344	394	444	494	544	594	644	694	744	794	844	894	944	994	1044	1094	1144	1194	1244	1294	1344	1394	1444	1494	1544	
	BM	330.5	380.5	430.5	480.5	530.5	580.5	630.5	680.5	730.5	780.5	830.5	880.5	930.5	980.5	1030.5	1080.5	1130.5	1180.5	1230.5	1280.5	1330.5	1380.5	1430.5	1480.5	1530.5	
A	100	50	100	50	100	50	100	50	100	50	100	50	100	50	100	50	100	50	100	50	100	50	100	50	100	50	
M	1	2	2	3	3	4	4	5	5	6	6	7	7	8	8	9	9	10	10	11	11	12	12	13	13	13	
N	6	8	8	10	10	12	12	14	14	16	16	18	18	20	20	22	22	24	24	26	26	28	28	30	30	30	
P	100	150	200	250	300	350	400	450	500	550	600	650	700	750	800	850	900	950	1000	1050	1100	1150	1200	1250	1300		
KG	BC	5.05	5.4	5.75	6.1	6.45	6.8	7.15	7.5	7.85	8.2	8.55	8.9	9.25	9.6	9.95	10.3	10.65	11	11.35	11.7	12.05	12.4	12.75	13.1	13.45	
	BM	5.21	5.56	5.91	6.26	6.61	6.96	7.31	7.66	8.01	8.36	8.71	9.06	9.41	9.76	10.11	10.46	10.81	11.16	11.51	11.86	12.21	12.56	12.91	13.26	13.61	
線速度 Linear Speed mm/s	導程 Lead 6												360														
	導程 Lead 12												720	350	310	270	240	210	190	170	160	140	130	120	110	100	
	導程 Lead 24												1440	700	620	540	480	420	380	340	320	280	260	240	220	200	

* 1 行程 50 時，因本體上鎖式固定孔會被滑座遮住，僅能使用 4 支螺絲固定，建議客戶本體使用下鎖式固定孔鎖附。When the stroke is 50mm, if fixing the body from the top to the bottom, the fixing hole will be blocked by slider and only can be uses 4 screws to fix; as a result, suggest that fixing actuator body from the bottom to the top.



Download at www.toyorobot.com

BL 馬達左折 Motor Left Side

單位 Unit : mm

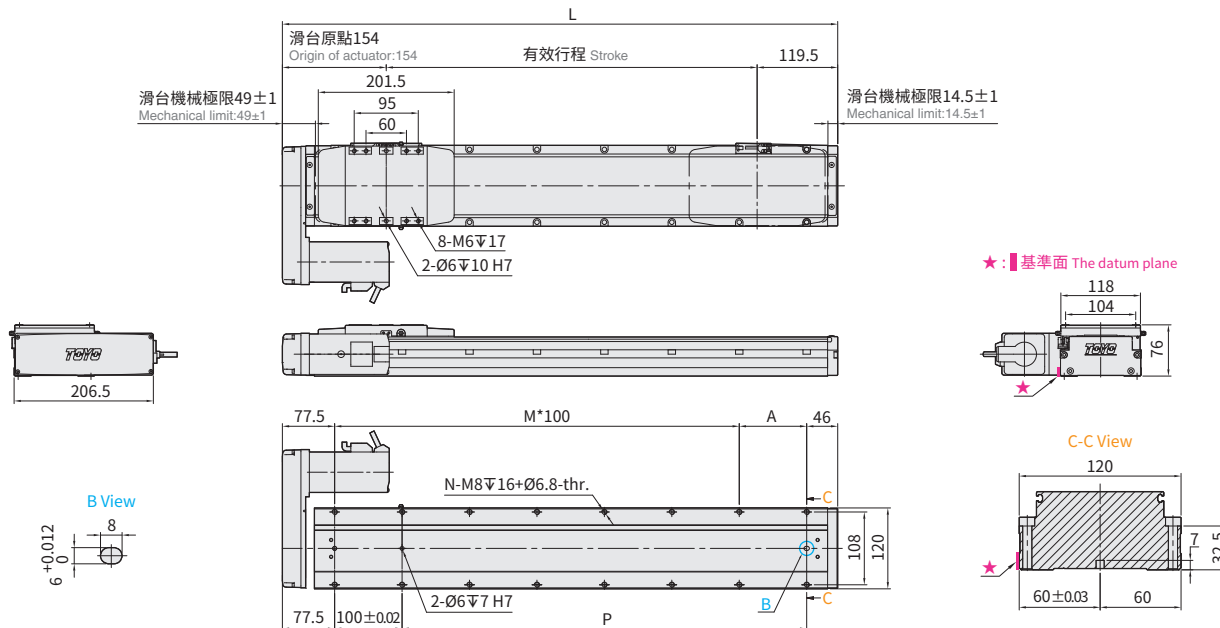

BR 馬達右折 Motor Right Side

單位 Unit : mm

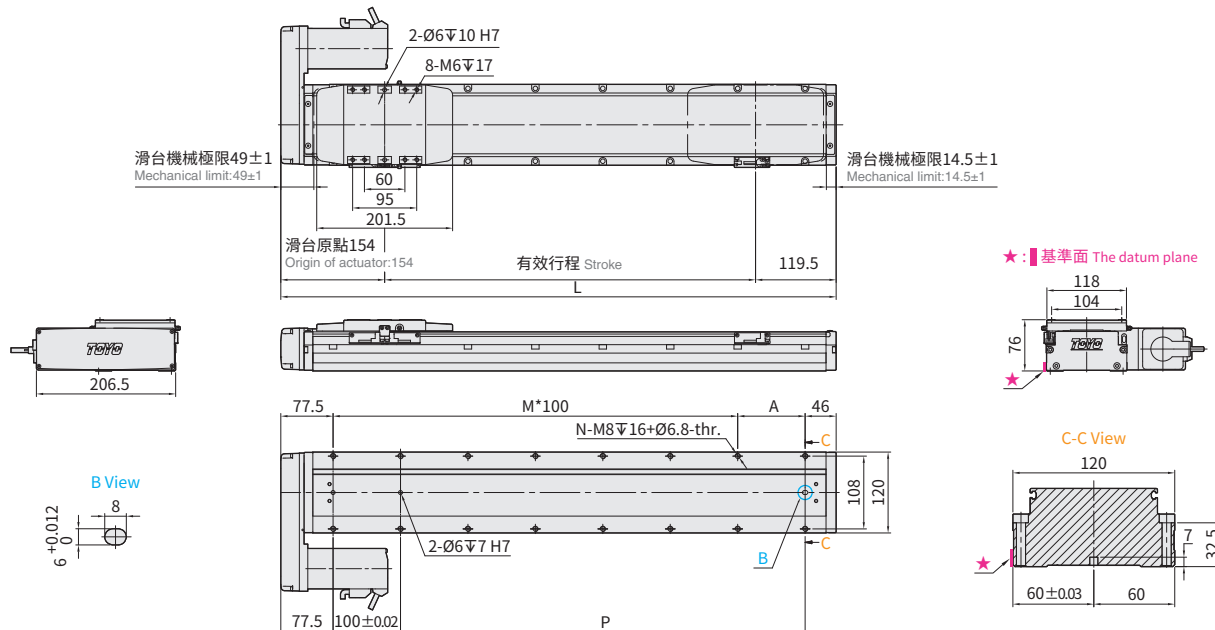

有效行程 Stroke	50 ⁻¹	100	150	200	250	300	350	400	450	500	550	600	650	700	750	800	850	900	950	1000	1050	1100	1150	1200	1250
極限行程 Limit Stroke (±1)	58.5	108.5	158.5	208.5	258.5	308.5	358.5	408.5	458.5	508.5	558.5	608.5	658.5	708.5	758.5	808.5	858.5	908.5	958.5	1008.5	1058.5	1108.5	1158.5	1208.5	1258.5
L	323.5	373.5	423.5	473.5	523.5	573.5	623.5	673.5	723.5	773.5	823.5	873.5	923.5	973.5	1023.5	1073.5	1123.5	1173.5	1223.5	1273.5	1323.5	1373.5	1423.5	1473.5	1523.5
A	100	50	100	50	100	50	100	50	100	50	100	50	100	50	100	50	100	50	100	50	100	50	100	50	100
M	1	2	2	3	3	4	4	5	5	6	6	7	7	8	8	9	9	10	10	11	11	12	12	13	13
N	6	8	8	10	10	12	12	14	14	16	16	18	18	20	20	22	22	24	24	26	26	28	28	30	30
P	100	150	200	250	300	350	400	450	500	550	600	650	700	750	800	850	900	950	1000	1050	1100	1150	1200	1250	1300
KG	5.25	5.6	5.95	6.3	6.65	7	7.35	7.7	8.05	8.4	8.75	9.1	9.45	9.8	10.15	10.5	10.85	11.2	11.55	11.9	12.25	12.6	12.95	13.3	13.65
線速度 Linear Speed mm/s	導程 Lead 6	360											350	310	270	240	210	190	170	160	140	130	120	110	100
	導程 Lead 12	720											700	620	540	480	420	380	340	320	280	260	240	220	200
	導程 Lead 24	1440											1400	1240	1080	960	840	760	680	640	560	520	480	440	400

※1 行程 50 時，因本體上鎖式固定孔會被滑座遮住，僅能使用 4 支螺絲固定，建議客戶本體使用下鎖式固定孔鎖附。When the stroke is 50mm, if fixing the body from the top to the bottom, the fixing hole will be blocked by slider and only can be uses 4 screws to fix; as a result, suggest that fixing actuator body from the bottom to the top.

應用例
Application

一般 / 螺桿仕様
GLTH

一般 / 皮帶仕様
ETB / M

無塵 / 螺桿仕様
GCH / ECH

無塵 / 皮帶仕様
ECB

直交連結
XYGT / XYTH / XYTB

參考資料
Reference

GLTH Series

GLTH3

GLTH5

GLTH8

GLTH12

GLTH5D

GLTH8D

GLMH5

GLMH8

GLTH5M

GLTH8M

GLTH5D 單軸 /1-axis

▶ 軌道內嵌
Integrated Linear Bearing

▶ 螺桿驅動
Ball Screw Drive

精度
±0.005 mm

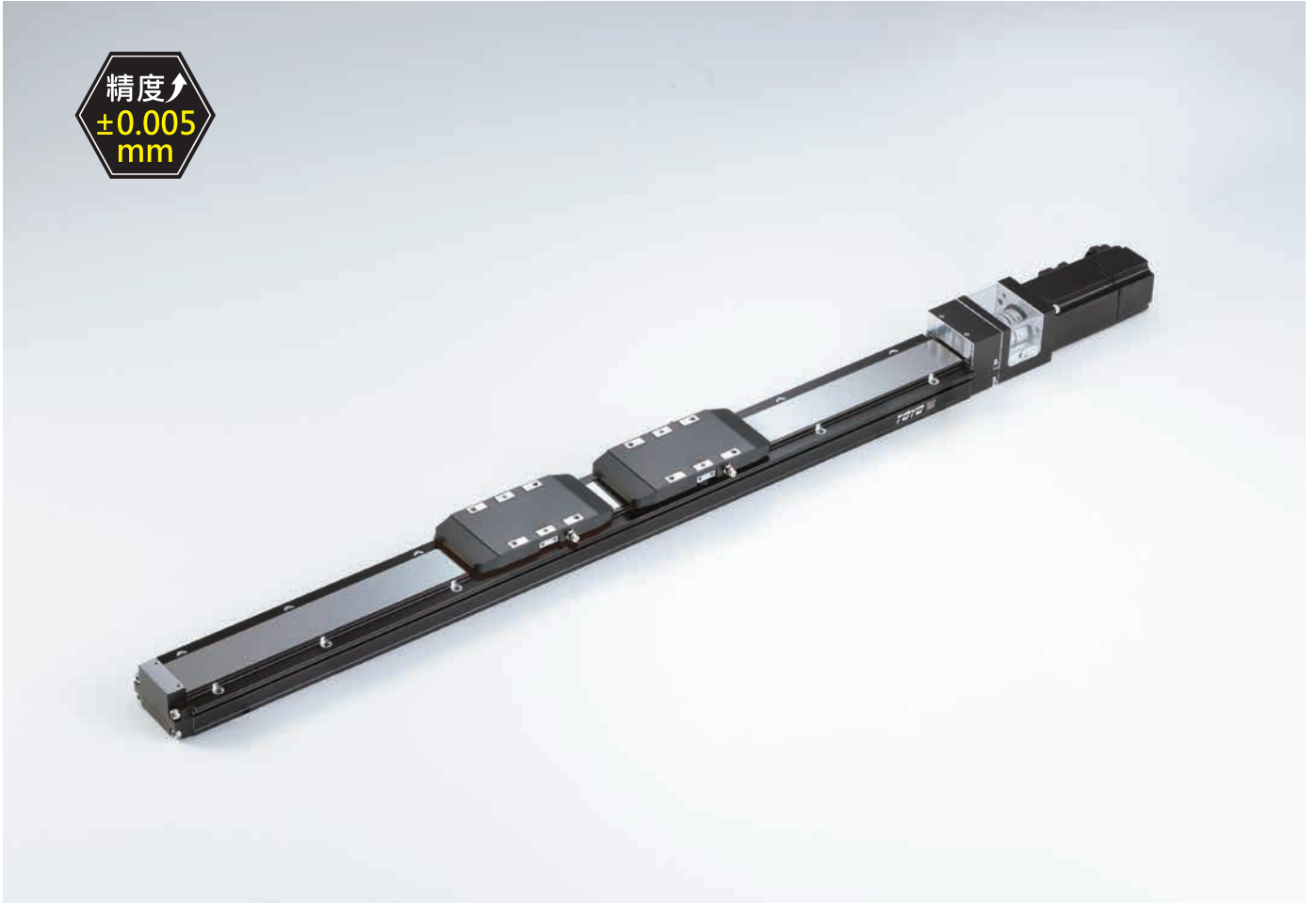

最大行程
Maximum Stroke 850mm

最高速度
Maximum Speed 1200mm/s

馬達容量
Motor Output 100W

最大可搬重量
Max Payload 30kg

型號表示方式 Ordering Method

GLTH5D - L2 - 100 - BC - M10B - C4N5 - 參照右頁 - 0001

本體型號
Model

行程¹
Stroke
50-850mm
50間隔 50 mm Pitch

選配
Options

特注式樣
Customization Order No.

螺桿導程
Ball Screw Lead

2	2mm
6	6mm
12	12mm
20	20mm

馬達位置
Motor Position

BC	馬達外露 Motor Exposed
BM	馬達下折 Motor Bottom Side
BL	馬達左折 Motor Left Side
BR	馬達右折 Motor Right Side

馬達廠牌、功率
Motor Brand · Power Output

M	三菱 Mitsubishi	05	-	B ²
P	松下 Panasonic	10	100W	
Y	安川 Yaskawa	20	-	
T	台達 Delta	40	-	

原點感應器
Home Sensor

外掛型 Out Side	
C	馬達側 Motor Side
D	反馬達側 Opposite Motor Side
無 SENSOR No Sensor	
E	無 SENSOR No Sensor

端點極限感應器
Limit Sensor

外掛型 Out Side	
3	1只 1 Pc
4	2只 2 Pcs
6	3只 3 Pcs
7	4只 4 Pcs
8	5只 5 Pcs
9	6只 6 Pcs
無 SENSOR No Sensor	
5	無 SENSOR No Sensor

輸出方式&線長
Output type & Cable length

N5	NPN+5米線 NPN+5M Cable
P2	PNP+2米線 PNP+2M Cable
P5	PNP+5米線 PNP+5M Cable
-	NPN+2米線 NPN+2M Cable

¹選擇行程50時，光電使用有以下限制：When the stroke is 50mm, the sensor installation has the following restrictions:

馬達方向 BC/BM：1.原點與極限需放置於不同側。2.滑座左右兩側皆需安裝感應片。Motor Direction BC/BM 1.Home sensor and limit sensor has to be installed on the different side of body. 2.Both sides of slider need to install the sensor trigger device.

馬達方向 BL/BR：1.原點+極限感應器最數量最多2只(僅能選用C3/D3/E3/E4/E5)。Motor Direction BL/BR 1.Home + limit sensors is 2 maximum (only C3/D3/E3/E4/E5 can be selected)

²馬達若無煞車則不表示。If Motor No Brake, No Description.

基本仕様 Specification

性能	位置重複精度 Repeatability	mm	±0.005				
	螺桿導程 Lead	mm	2	6	12	20	
	最高轉速 Maximum Rotating speed	rpm	3600	3600	3600	3600	
	最高速度 Maximum linear speed ^{※1}	mm/s	120	300	720	1200	
	最大可搬重量 ^{※2} Maximum Payload	水平使用 Horizontal	kg	30	25	22	10
		垂直使用 Vertical	kg	10	6	4	3
	定格推力 Rated Thrust	N	854	285	142	85	
	標準行程 Stroke (increments)	mm	50-850mm / 50 間隔 (50 increments)				
	最大加速度 Maximum acceleration	G	0.12	0.37	0.73	1.22	
	滾珠螺桿 Ball screw	基本動額定負荷 Basic dynamic load rating Ca	N	2270	2243	1436	1384
基本靜額定負荷 Basic static load rating Coa		N	4836	3959	2441	2535	
直線滑軌 Linear Guide	動態水平負載 Dynamic horizontal (100km)	N	6563				
	靜態水平負載 Static Horizontal	N	13587				
固定側軸承 Fixed bearing	基本動額定負荷 Basic dynamic load rating Cr	N	5361				
	靜態容許負荷 Static load rating Cor	N	2880				
部品	AC 伺服馬達容量 AC Servo Motor Output	W	100				
	滾珠螺桿外徑 Ball Screw Ø	mm	C7Ø10				
	連軸器 Coupling	mm	7X8				
	原點感應器 Home Sensor	外掛 Outside	T64N2 (NPN+2 米線) (NPN+2M Cable)				

※1 長行程時，會產生螺桿偏擺，需將速度調降 (線速度請參閱尺寸圖下方表格)

During in a long stroke, it causes ballscrew deflection, the speed must reduce. (Please refer to the linear velocity from the data sheet below the dimension graph.)

※2 由於各廠牌的馬達性能不同，需速度搭配回升電阻以達到此荷重條件。

Since the motor performance of each brand is different, a regenerative resistor needs to be appropriately matched to achieve this load condition.

容許負載力距表 Allowable Overhang

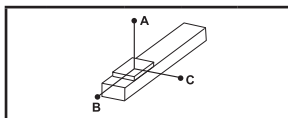

(單位 Unit: mm)

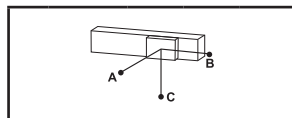

(單位 Unit: mm)

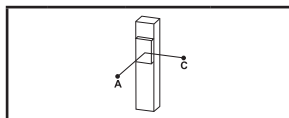

(單位 Unit: mm)

水平安裝 Horizontal Installation		A	B	C
導程 2 Lead	10kg	2500	157	250
	20kg	1120	70	112
	30kg	650	41	65
導程 6 Lead	10kg	1400	122	184
	20kg	650	52	79
	25kg	490	38	57
導程 12 Lead	8kg	590	132	175
	10kg	460	103	135
	22kg	185	37	49
導程 20 Lead	3kg	656	300	303
	6kg	314	141	144
	10kg	177	78	79

壁掛安裝 Wall Installation		A	B	C
導程 2 Lead	10kg	250	157	2500
	20kg	112	70	1120
	30kg	65	41	650
導程 6 Lead	10kg	184	122	1400
	20kg	79	52	650
	25kg	57	38	490
導程 12 Lead	8kg	175	132	590
	10kg	135	103	460
	22kg	49	37	185
導程 20 Lead	3kg	303	300	656
	6kg	144	141	314
	10kg	79	78	177

垂直安裝 Vertical Installation		A	C
導程 2 Lead	5kg	346	346
	10kg	173	173
	-	-	-
導程 6 Lead	3kg	463	463
	6kg	231	231
	-	-	-
導程 12 Lead	2.5kg	465	465
	4kg	292	292
	-	-	-
導程 20 Lead	1.5kg	555	555
	3kg	278	278
	-	-	-

靜額定扭矩 Static Loading Moment

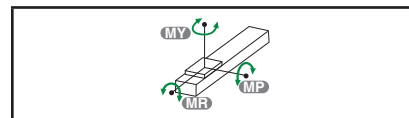

(單位 Unit: N.m)

MY	73
MP	73
MR	115

* 力矩表所表示的數據，代表荷重的重心位置於單方向容許懸出的長度。
The data represented by the moment table is the center of gravity of the load. The length of the overhang is allowed in a single direction.

* 符合型錄規範的正常情況下，保證壽命為 10000 公里。

Operation life is 10,000km when the product is using under the specified conditions.

* 倒吊使用無法套用標準規範，如有需求請洽詢我司業務。

Data information is not for ceiling-mount inverse use.

Contact us for the details if you want to apply ceiling-mount inverse usage.

* 壽命及力矩是以馬達加速減速設定 0.2 秒計算。

The life and torque are calculated by setting the motor acceleration and deceleration for 0.2 seconds.

選配 Options

MM

指定馬達出線方向 Selectable Cable Leading Direction		
代號 Code	說明 Instructions	需參照 Refer to
MW	朝上 Upper side	P.111 ~ P.112
MM	朝下 Bottom side	
ML	朝左 Left side	
MR	朝右 Right side	

CMK

馬達傳動配件追加鍵槽 Additional keyway for motor drive parts				
代號 Code	說明 Instructions			需參照 Refer to
	追加鍵槽 Keyway Groove	馬達位置 Motor Position	出貨型式 Shipment Type	
CMK	單邊 (限定馬達側) Single (Limited to the motor side)	BC	鍵槽式聯軸器 Keyway Coupling	P.113 ~ P.115
		BL/BR/BM	鍵槽式皮帶輪 Keyway Belt Pulley	
SKY	雙邊 Double	BC	鍵槽式聯軸器 Keyway Coupling	
		BL/BR/BM	鍵槽式皮帶輪 Keyway Belt Pulley	
SKN	雙邊 Double	BC	無聯軸器 (請自行購買安裝) Without Coupling (Please purchase and install by yourself)	
		BL/BR/BM	無馬達端皮帶輪 (請自行購買安裝) Without Belt Pulley (Please purchase and install by yourself)	

GLTH Series

- GLTH3
- GLTH5
- GLTH8
- GLTH12
- GLTH5D**
- GLTH8D
- GLMH5
- GLMH8
- GLTH5M
- GLTH8M

GLTH5D 單軸 /1-axis

▶ 軌道內嵌
Integrated Linear Bearing

▶ 螺桿驅動
Ball Screw Drive



Download at www.toyorobot.com

BC 馬達外露 Motor Exposed

單位 Unit : mm

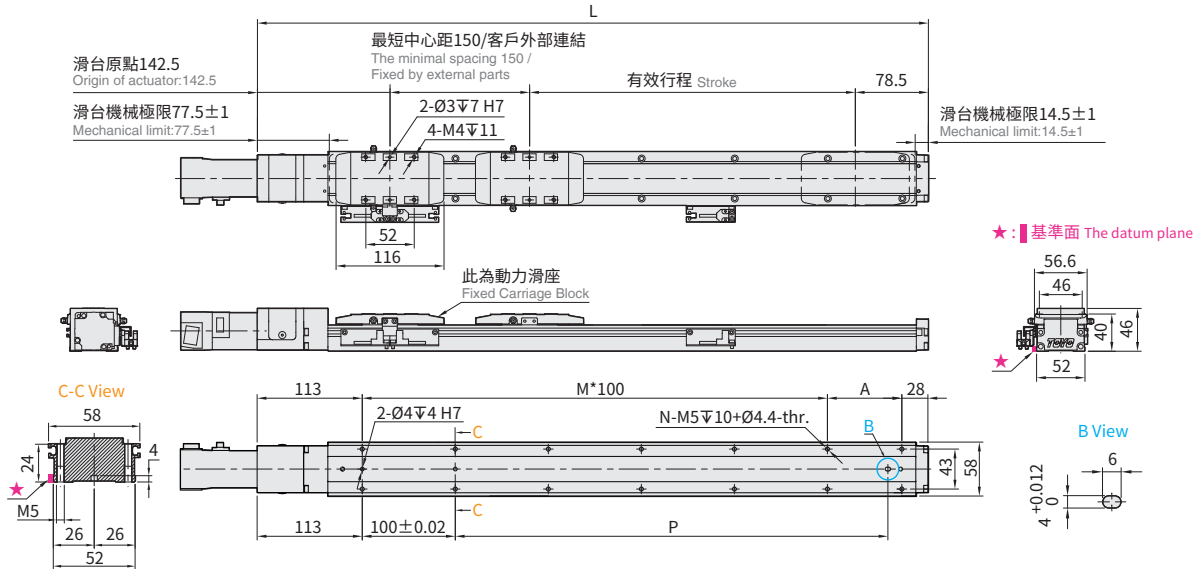

BM 馬達下折 Motor Bottom Side

單位 Unit : mm

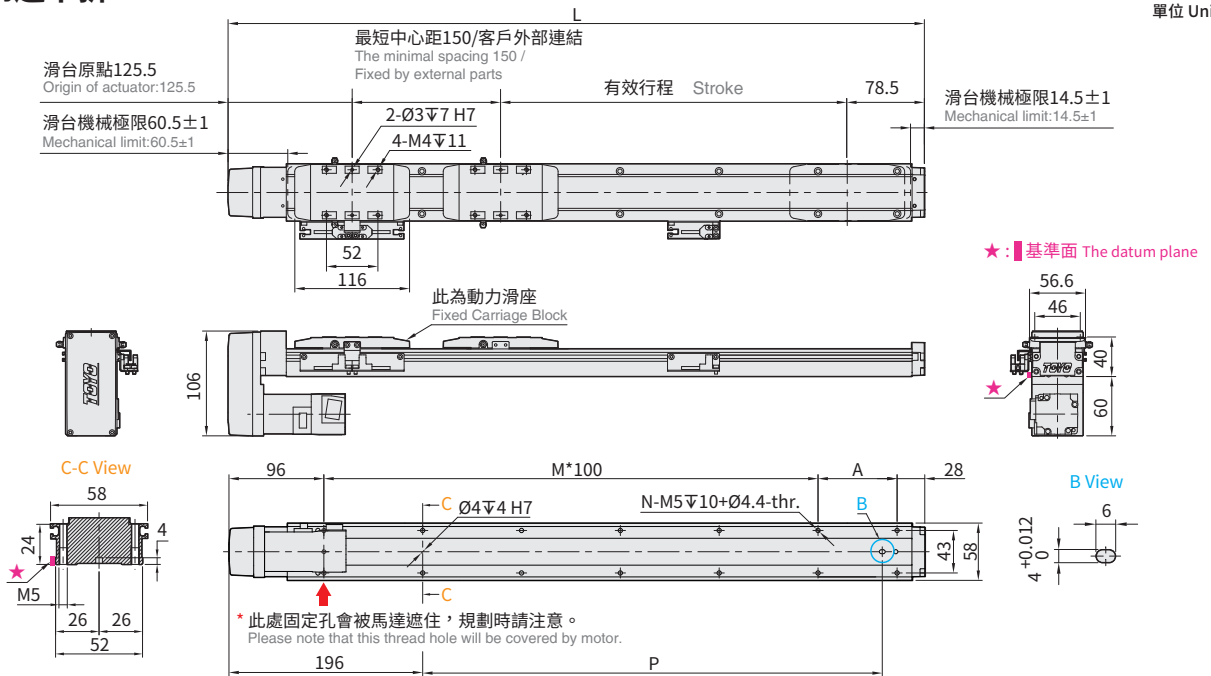

有效行程 Stroke	50 ⁻¹	100	150	200	250	300	350	400	450	500	550	600	650	700	750	800	850	
極限行程 Limit Stroke (±1)	63	113	163	213	263	313	363	413	463	513	563	613	663	713	763	813	863	
L	BC	421	471	521	571	621	671	721	771	821	871	921	971	1021	1071	1121	1171	1221
	BM	404	454	504	554	604	654	704	754	804	854	904	954	1004	1054	1104	1154	1204
A	80	30	80	30	80	30	80	30	80	30	80	30	80	30	80	30	80	
M	2	3	3	4	4	5	5	6	6	7	7	8	8	9	9	10	10	
N	8	10	10	12	12	14	14	16	16	18	18	20	20	22	22	24	24	
P	165	215	265	315	365	415	465	515	565	615	665	715	765	815	865	915	965	
KG	BC	1.57	1.7	1.82	1.95	2.08	2.2	2.33	2.46	2.58	2.71	2.84	2.96	3.09	3.21	3.34	3.47	3.59
	BM	1.67	1.8	1.92	2.05	2.18	2.3	2.43	2.56	2.68	2.81	2.94	3.06	3.19	3.31	3.44	3.57	3.69
線速度 Linear Speed mm/s	導程 Lead 2				120			110	90	80	70	63	53	50	43	40	36	
	導程 Lead 6				360			330	270	240	210	190	160	150	130	120	110	
	導程 Lead 12				720			660	540	480	420	380	320	300	260	240	220	
	導程 Lead 20				1200			1100	900	800	700	633	533	500	433	400	367	

※1 行程 50 時，因本體上鎖式固定孔會被滑座遮住，僅能使用 4 支螺絲固定，建議客戶本體使用下鎖式固定孔鎖附。When the stroke is 50mm, if fixing the body from the top to the bottom, the fixing hole will be blocked by slider and only can be uses 4 screws to fix, as a result, suggest that fixing actuator body from the bottom to the top.



Download at www.toyorobot.com

BL 馬達左折 Motor Left Side

單位 Unit : mm

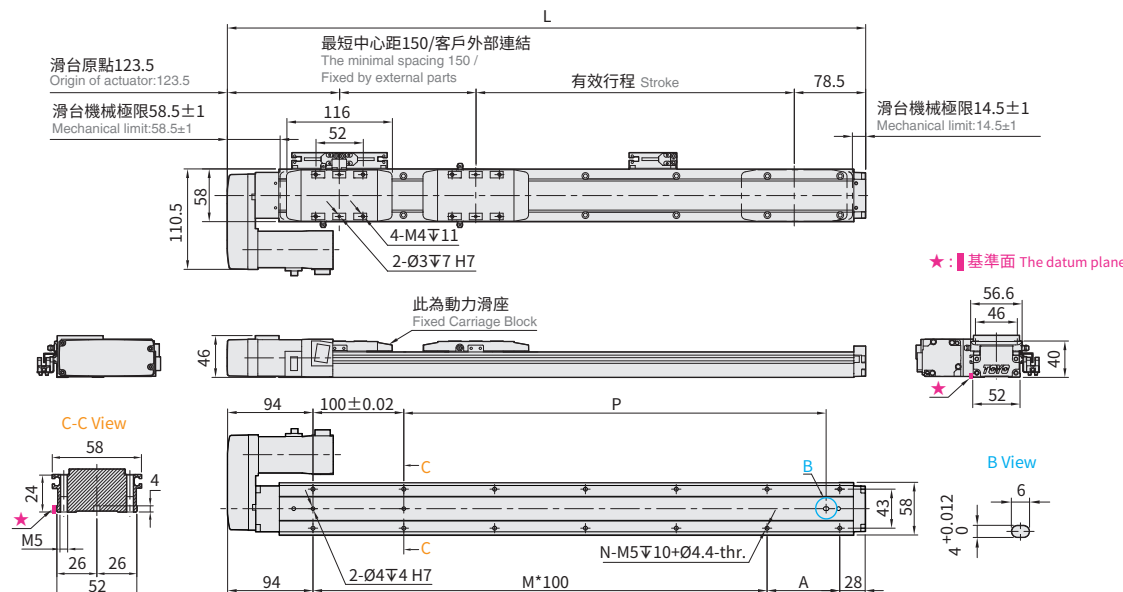

BR 馬達右折 Motor Right Side

單位 Unit : mm

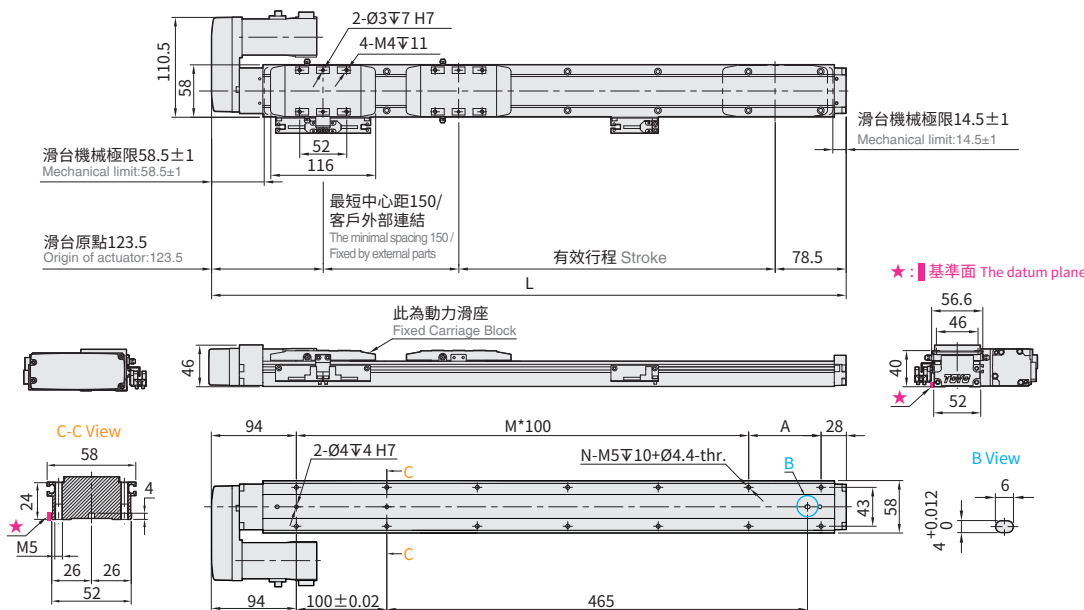

有效行程 Stroke	50 ^{±1}	100	150	200	250	300	350	400	450	500	550	600	650	700	750	800	850
極限行程 Limit Stroke (±1)	63	113	163	213	263	313	363	413	463	513	563	613	663	713	763	813	863
L	402	452	502	552	602	652	702	752	802	852	902	952	1002	1052	1102	1152	1202
A	80	30	80	30	80	30	80	30	80	30	80	30	80	30	80	30	80
M	2	3	3	4	4	5	5	6	6	7	7	8	8	9	9	10	10
N	8	10	10	12	12	14	14	16	16	18	18	20	20	22	22	24	24
P	165	215	265	315	365	415	465	515	565	615	665	715	765	815	865	915	965
KG	1.67	1.8	1.92	2.05	2.18	2.3	2.43	2.56	2.68	2.81	2.94	3.06	3.19	3.31	3.44	3.57	3.69
線速度 Linear Speed mm/s	導程 Lead 2	120															
	導程 Lead 6	360															
	導程 Lead 12	720															
	導程 Lead 20	1200															

※1 行程 50 時，因本體上鎖式固定孔會被滑座遮住，僅能使用 4 支螺絲固定，建議客戶本體使用下鎖式固定孔鎖附。When the stroke is 50mm, if fixing the body from the top to the bottom, the fixing hole will be blocked by slider and only can be uses 4 screws to fix, as a result, suggest that fixing actuator body from the bottom to the top.

應用例
Application

一般 / 螺桿仕様
GLTH

一般 / 皮帶仕様
ETB / M

無塵 / 螺桿仕様
GCH / ECH

無塵 / 皮帶仕様
ECB

直交連結
XYGT / XYTH / XYTB

參考資料
Reference

GLTH Series

GLTH3

GLTH5

GLTH8

GLTH12

GLTH5D

GLTH8D

GLMH5

GLMH8

GLTH5M

GLTH8M

GLTH8D 單軸 /1-axis

▶ 軌道內嵌
Integrated Linear Bearing

▶ 螺桿驅動
Ball Screw Drive

精度
±0.005 mm



最大行程
Maximum Stroke 1050mm

最高速度
Maximum Speed 1440mm/s

馬達容量
Motor Output 200W

最大可搬重量
Max Payload 80kg

型號表示方式 Ordering Method

GLTH8D - L6 - 100 - BC - M20B - C4N5 - 參照右頁
Refer to the right page. - 0001

本體型號
Model

行程¹
Stroke
50-1050mm
50間隔 50 mm Pitch

選配
Options

特注式樣
Customization Order No.

螺桿導程
Ball Screw Lead

6	6mm
12	12mm
24	24mm

馬達位置
Motor Position

BC	馬達外露 Motor Exposed
BM	馬達下折 Motor Bottom Side
BL	馬達左折 Motor Left Side
BR	馬達右折 Motor Right Side

馬達廠牌、功率
Motor Brand · Power Output

M	三菱 Mitsubishi	05	-	B ²
P	松下 Panasonic	10	-	
Y	安川 Yaskawa	20	200W	
T	台達 Delta	40	-	

原點感應器
Home Sensor

外掛型 Out Side	
C	馬達側 Motor Side
D	反馬達側 Opposite Motor Side
無 SENSOR No Sensor	
E	無 SENSOR No Sensor

端點極限感應器
Limit Sensor

外掛型 Out Side	
3	1只 1 Pc
4	2只 2 Pcs
6	3只 3 Pcs
7	4只 4 Pcs
8	5只 5 Pcs
9	6只 6 Pcs
無 SENSOR No Sensor	
5	無 SENSOR No Sensor

輸出方式&線長
Output type & Cable length

N5	NPN+5米線 NPN+5M Cable
P2	PNP+2米線 PNP+2M Cable
P5	PNP+5米線 PNP+5M Cable
-	NPN+2米線 NPN+2M Cable

¹選擇行程50時，光電使用有以下限制：When the stroke is 50mm, the sensor installation has the following restrictions:

馬達方向 BC/BM：1.原點與極限需放置於不同側。2.滑座左右兩側皆需安裝感應片。Motor Direction BC/BM 1.Home sensor and limit sensor has to be installed on the different side of body. 2.Both sides of slider need to install the sensor trigger device.

馬達方向 BL/BR：1.原點+極限感應器最數量最多2只(僅能選用C3/D3/E3/E4/E5)。Motor Direction BL/BR 1.Home + limit sensors is 2 maximum (only C3/D3/E3/E4/E5 can be selected)

²馬達若無煞車則不表示。If Motor No Brake, No Description.

基本仕様 Specification

性能	位置重複精度 Repeatability	mm	±0.005			
	螺桿導程 Lead	mm	6	12	24	
	最高轉速 Maximum Rotating speed	rpm	3600	3600	3600	
	最高速度 Maximum linear speed ※1	mm/s	360	720	1440	
	最大可搬重量 ※2 Maximum Payload	水平使用 Horizontal	kg	80	60	40
		垂直使用 Vertical	kg	15	8	5
	定格推力 Rated Thrust	N	569	284	142	
	標準行程 Stroke (increments)	mm	50-1050mm / 50 間隔 (50 increments)			
	最大加速度 Maximum acceleration	G	0.37	0.73	1.47	
	滾珠螺桿 Ball screw	基本動額定負荷 Basic dynamic load rating Ca	N	7733	5855	3007
基本靜額定負荷 Basic static load rating Coa		N	14200	10401	5414	
直線滑軌 Linear Guide	動態水平負載 Dynamic horizontal (100km)	N	18601			
	靜態水平負載 Static Horizontal	N	34189			
固定側軸承 Fixed bearing	基本動額定負荷 Basic dynamic load rating Cr	N	8447			
	靜態容許負荷 Static load rating Cor	N	5060			
部品	AC 伺服馬達容量 AC Servo Motor Output	W	200			
	滾珠螺桿外徑 Ball Screw Ø	mm	C7Ø14			
	連軸器 Coupling	mm	10X14 / 11 ※3			
	原點感應器 Home Sensor	外掛 Outside	T64N2 (NPN+2 米線) (NPN+2M Cable)			

※1 長行程時，會產生螺桿偏擺，需將速度調降 (線速度請參閱尺寸圖下方表格)
During in a long stroke, it causes ballscrew deflection, the speed must reduce. (Please refer to the linear velocity from the data sheet below the dimension graph.)
※2 由於各廠牌的馬達性能不同，需適度搭配回升電阻以達到此荷重條件。
Since the motor performance of each brand is different, a regenerative resistor needs to be appropriately matched to achieve this load condition.
※3 使用 Panasonic 200W 馬達時，馬達軸心為 Ø11；其他廠牌，馬達軸心為 Ø14。Motor (200W) Shaft Diameter: Panasonic: 11mm; Other: 14mm.

容許負載力距表 Allowable Overhang

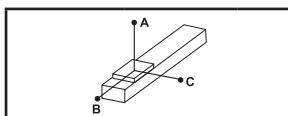

(單位 Unit: mm)

水平安裝 Horizontal Installation	A	B	C
導程 6 Lead	35kg	1600	139 220
	45kg	1210	102 160
	80kg	620	46 74
導程 12 Lead	10kg	2040	470 645
	30kg	638	141 193
	60kg	283	58 80
導程 24 Lead	20kg	253	145 133
	40kg	109	60 55
	-	-	- -

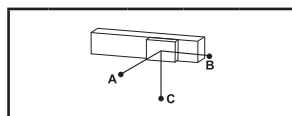

(單位 Unit: mm)

壁掛安裝 Wall Installation	A	B	C
導程 6 Lead	35kg	220	139 1600
	45kg	160	102 1210
	80kg	74	46 620
導程 12 Lead	10kg	645	470 2040
	30kg	193	141 638
	60kg	80	58 283
導程 24 Lead	20kg	133	145 253
	40kg	55	60 109
	-	-	- -

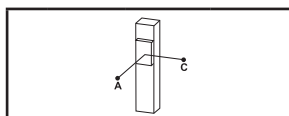

(單位 Unit: mm)

垂直安裝 Vertical Installation	A	C
導程 6 Lead	10kg	535
	15kg	360
	-	-
導程 12 Lead	3.5kg	1380
	8kg	605
	-	-
導程 24 Lead	2kg	1380
	5kg	556
	-	-

靜額定扭矩 Static Loading Moment

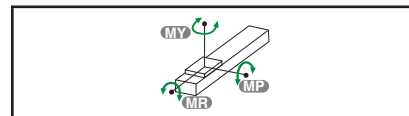

(單位 Unit: N.m)

MY	137
MP	137
MR	227

* 力矩表所表示的數據，代表荷重的重心位置於單一方向容許懸出的長度。
The data represented by the moment table is the center of gravity of the load. The length of the overhang is allowed in a single direction.
* 符合型錄規範的正常使用下，保證壽命為 10000 公里。
Operation life is 10,000km when the product is using under the specified conditions.
* 倒吊使用無法套用標準規範，如有需求請洽詢我司業務。
Data information is not for ceiling-mount inverse use. Contact us for the details if you want to apply ceiling-mount inverse usage.
* 壽命及力矩是以馬達加速減速設定 0.2 秒計算。
The life and torque are calculated by setting the motor acceleration and deceleration for 0.2 seconds.

選配 Options

MM

指定馬達出線方向 Selectable Cable Leading Direction		
代號 Code	說明 Instructions	需參照 Refer to
MW	朝上 Upper side	P.111 ~ P.112
MM	朝下 Bottom side	
ML	朝左 Left side	
MR	朝右 Right side	

CMK

馬達傳動配件追加鍵槽 Additional keyway for motor drive parts				
代號 Code	說明 Instructions			需參照 Refer to
	追加鍵槽 Keyway Groove	馬達位置 Motor Position	出貨型式 Shipment Type	
CMK	單邊 (限定馬達側) Single (Limited to the motor side)	BC	鍵槽式聯軸器 Keyway Coupling	P.113 ~ P.115
		BL/BR/BM	鍵槽式皮帶輪 Keyway Belt Pulley	
SKY	雙邊 Double	BC	鍵槽式聯軸器 Keyway Coupling	
		BL/BR/BM	鍵槽式皮帶輪 Keyway Belt Pulley	
SKN	雙邊 Double	BC	無聯軸器 (請自行購買安裝) Without Coupling (Please purchase and install by yourself)	
		BL/BR/BM	無馬達端皮帶輪 (請自行購買安裝) Without Belt Pulley (Please purchase and install by yourself)	

GLTH Series

- GLTH3
- GLTH5
- GLTH8
- GLTH12
- GLTH5D
- GLTH8D**
- GLMH5
- GLMH8
- GLTH5M
- GLTH8M

GLTH8D 單軸 /1-axis

▶ 軌道內嵌
Integrated Linear Bearing

▶ 螺桿驅動
Ball Screw Drive



• Download at www.toyorobot.com •

BC 馬達外露 Motor Exposed

單位 Unit : mm

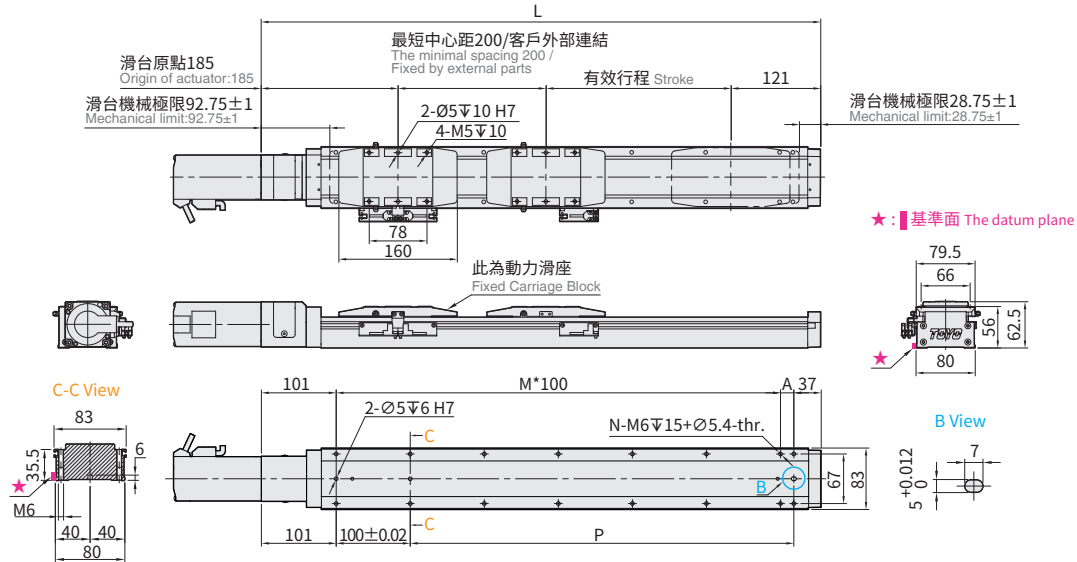

BM 馬達下折 Motor Bottom Side

單位 Unit : mm

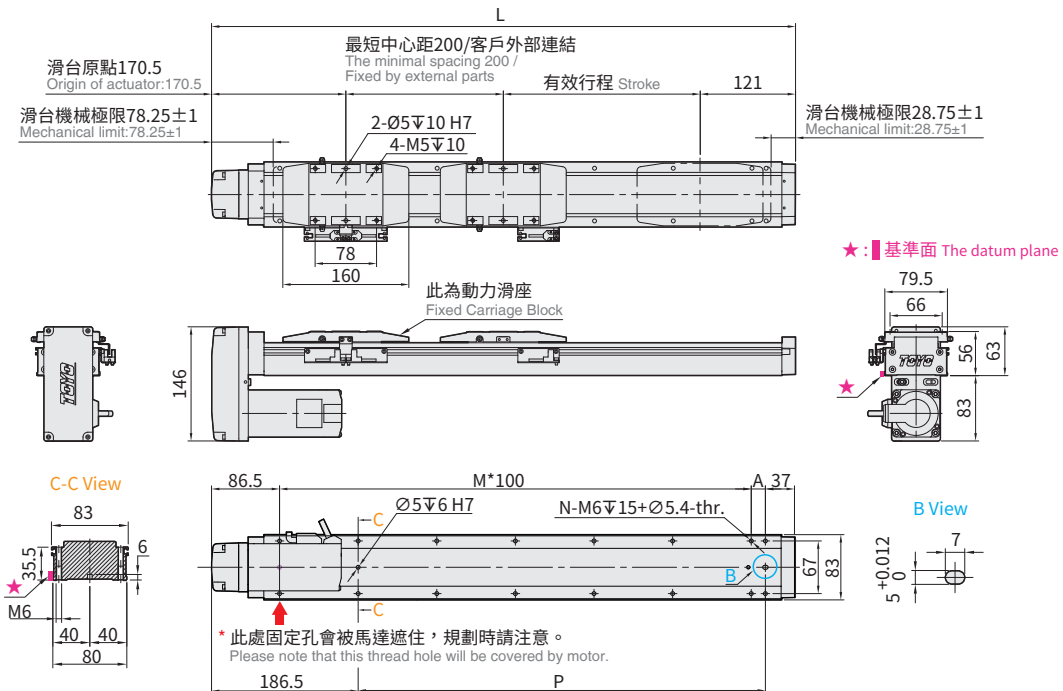

有效行程 Stroke	50 ^{±1}	100	150	200	250	300	350	400	450	500	550	600	650	700	750	800	850	900	950	1000	1050				
極限行程 Limit Stroke (±1)	74.5	124.5	174.5	224.5	274.5	324.5	374.5	424.5	474.5	524.5	574.5	624.5	674.5	724.5	774.5	824.5	874.5	924.5	974.5	1024.5	1074.5				
L	BC	556	606	656	706	756	806	856	906	956	1006	1056	1106	1156	1206	1256	1306	1356	1406	1456	1506	1556			
	BM	541.5	591.5	641.5	691.5	741.5	791.5	841.5	891.5	941.5	991.5	1041.5	1091.5	1141.5	1191.5	1241.5	1291.5	1341.5	1391.5	1441.5	1491.5	1541.5			
A	18	68	18	68	18	68	18	68	18	68	18	68	18	68	18	68	18	68	18	68	18	68			
M	4	4	5	5	6	6	7	7	8	8	9	9	10	10	11	11	12	12	13	13	14	14			
N	12	12	14	14	16	16	18	18	20	20	22	22	24	24	26	26	28	28	30	30	32	32			
P	BC	318	368	418	468	518	568	618	668	718	768	818	868	918	968	1018	1068	1118	1168	1218	1268	1318			
	BM	3.89	4.19	4.49	4.78	5.08	5.37	5.67	5.97	6.27	6.56	6.86	7.15	7.45	7.75	8.04	8.34	8.64	8.93	9.23	9.53	9.82			
KG	BC	4.27	4.56	4.86	5.15	5.45	5.75	6.04	6.34	6.64	6.93	7.23	7.53	7.82	8.12	8.41	8.71	9.01	9.3	9.6	9.9	10.19			
	BM	3.89	4.19	4.49	4.78	5.08	5.37	5.67	5.97	6.27	6.56	6.86	7.15	7.45	7.75	8.04	8.34	8.64	8.93	9.23	9.53	9.82			
線速度 Linear Speed mm/s	導程 Lead 6	360										350	310	270	240	210	190	170	160	140	130	120	110	100	90
	導程 Lead 12	720										700	620	540	480	420	380	340	320	280	260	240	220	200	180
	導程 Lead 24	1440										1400	1240	1080	960	840	760	680	640	560	520	480	440	400	360

※1 行程 50 時，因本體上鎖式固定孔會被滑座遮住，僅能使用 4 支螺絲固定，建議客戶本體使用下鎖式固定孔鎖附。When the stroke is 50mm, if fixing the body from the top to the bottom, the fixing hole will be blocked by slider and only can be uses 4 screws to fix, as a result, suggest that fixing actuator body from the bottom to the top.



Download at www.toyorobot.com

BL 馬達左折 Motor Left Side

單位 Unit : mm

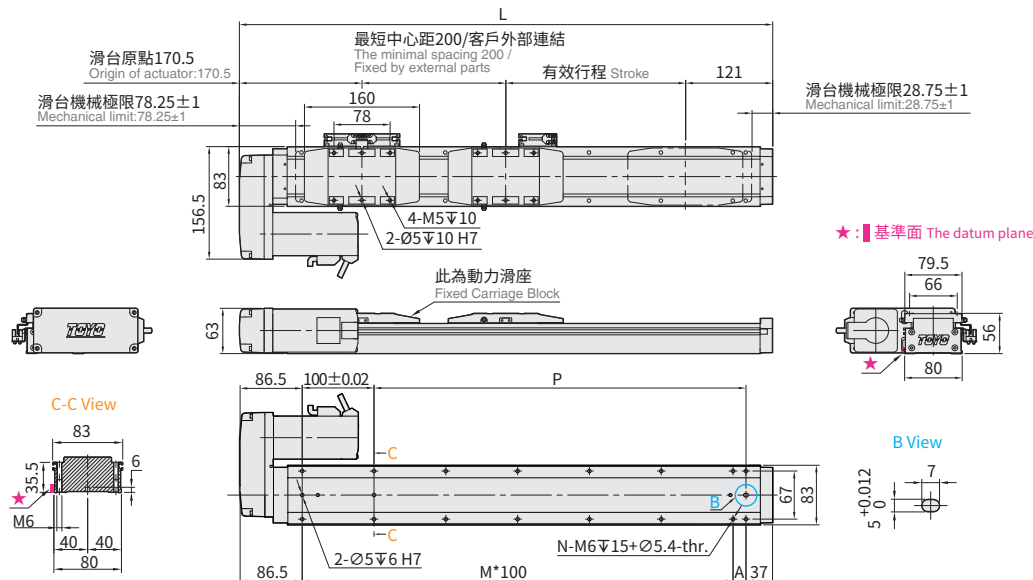

BR 馬達右折 Motor Right Side

單位 Unit : mm

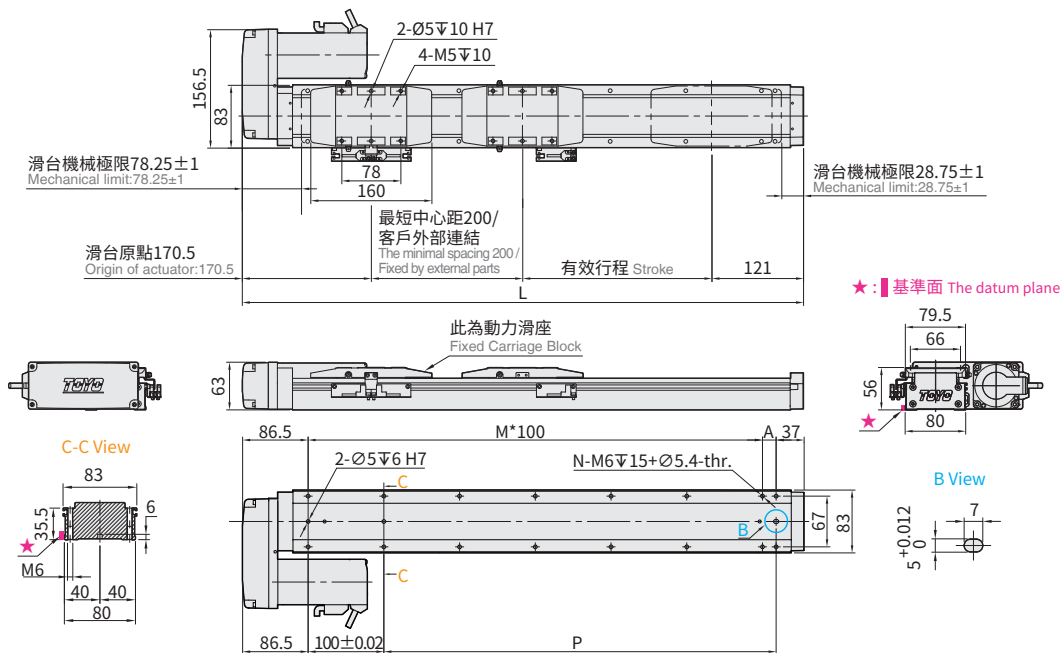

有效行程 Stroke	50 ^{※1}	100	150	200	250	300	350	400	450	500	550	600	650	700	750	800	850	900	950	1000	1050																																												
極限行程 Limit Stroke (±1)	74.5	124.5	174.5	224.5	274.5	324.5	374.5	424.5	474.5	524.5	574.5	624.5	674.5	724.5	774.5	824.5	874.5	924.5	974.5	1024.5	1074.5																																												
L	541.5	591.5	641.5	691.5	741.5	791.5	841.5	891.5	941.5	991.5	1041.5	1091.5	1141.5	1191.5	1241.5	1291.5	1341.5	1391.5	1441.5	1491.5	1541.5																																												
A	18	68	18	68	18	68	18	68	18	68	18	68	18	68	18	68	18	68	18	68	18																																												
M	4	4	5	5	6	6	7	7	8	8	9	9	10	10	11	11	12	12	13	13	14																																												
N	12	12	14	14	16	16	18	18	20	20	22	22	24	24	26	26	28	28	30	30	32																																												
P	318	368	418	468	518	568	618	668	718	768	818	868	918	968	1018	1068	1118	1168	1218	1268	1318																																												
KG	4.27	4.56	4.86	5.15	5.45	5.75	6.04	6.34	6.64	6.93	7.23	7.53	7.82	8.12	8.41	8.71	9.01	9.3	9.6	9.9	10.19																																												
線速度 Linear Speed mm/s	導程 Lead 6					360				350				310				270				240				210				190				170				160				140				130				120				110				100				90			
	導程 Lead 12					720				700				620				540				480				420				380				340				320				280				260				240				220				200				180			
	導程 Lead 24					1440				1400				1240				1080				960				840				760				680				640				560				520				480				440				400				360			

※1 行程 50 時，因本體上鎖式固定孔會被滑座遮住，僅能使用 4 支螺絲固定，建議客戶本體使用下鎖式固定孔鎖附。When the stroke is 50mm, if fixing the body from the top to the bottom, the fixing hole will be blocked by slider and only can be uses 4 screws to fix, as a result, suggest that fixing actuator body from the bottom to the top.

GLTH8D 單軸 /1-axis

▶ 軌道內嵌
Integrated Linear Bearing

▶ 螺桿驅動
Ball Screw Drive

精度
±0.005 mm



最大行程
Maximum Stroke 1050mm

最高速度
Maximum Speed 1440mm/s

馬達容量
Motor Output 400W

最大可搬重量
Max Payload 80kg

型號表示方式 Ordering Method

GLTH8D - L6 - 100 - BC - M40B - C4N5 - 參照右頁
Refer to the right page. - 0001

本體型號
Model

行程¹
Stroke

50-1050mm
50間隔 50 mm Pitch

選配
Options

特注式樣
Customization Order No.

螺桿導程
Ball Screw Lead

6	6mm
12	12mm
24	24mm

馬達位置
Motor Position

BC	馬達外露 Motor Exposed
BM	馬達下折 Motor Bottom Side
BL	馬達左折 Motor Left Side
BR	馬達右折 Motor Right Side

馬達廠牌、功率
Motor Brand · Power Output

M	三菱 Mitsubishi	05	-	B ²
P	松下 Panasonic	10	-	
Y	安川 Yaskawa	20	-	
T	台達 Delta	40	400W	

原點感應器
Home Sensor

外掛型 Out Side	
C	馬達側 Motor Side
D	反馬達側 Opposite Motor Side
無 SENSOR No Sensor	
E	無 SENSOR No Sensor

端點極限感應器
Limit Sensor

外掛型 Out Side	
3	1只 1 Pc
4	2只 2 Pcs
6	3只 3 Pcs
7	4只 4 Pcs
8	5只 5 Pcs
9	6只 6 Pcs
無 SENSOR No Sensor	
5	無 SENSOR No Sensor

輸出方式&線長
Output type & Cable length

N5	NPN+5米線 NPN+5M Cable
P2	PNP+2米線 PNP+2M Cable
P5	PNP+5米線 PNP+5M Cable
-	NPN+2米線 NPN+2M Cable

¹選擇行程50時，光電使用有以下限制：When the stroke is 50mm, the sensor installation has the following restrictions:

馬達方向 BC/BM：1.原點與極限需放置於不同側。2.滑座左右兩側皆需安裝感應片。Motor Direction BC/BM 1.Home sensor and limit sensor has to be installed on the different side of body. 2.Both sides of slider need to install the sensor trigger device.

馬達方向 BL/BR：1.原點+極限感應器最數量最多2只(僅能選用C3/D3/E3/E4/E5)。Motor Direction BL/BR 1.Home + limit sensors is 2 maximum (only C3/D3/E3/E4/E5 can be selected)

²馬達若無煞車則不表示。If Motor No Brake, No Description.

基本仕様 Specification

性能	位置重複精度 Repeatability	mm	±0.005			
	螺桿導程 Lead	mm	6	12	24	
	最高轉速 Maximum Rotating speed	rpm	3600	3600	3600	
	最高速度 Maximum linear speed ※1	mm/s	360	720	1440	
	最大可搬重量 ※2 Maximum Payload	水平使用 Horizontal	kg	105	85	40
		垂直使用 Vertical	kg	30	20	10
	定格推力 Rated Thrust	N	1156	578	289	
	標準行程 Stroke (increments)	mm	50-1050mm / 50 間隔 (50 increments)			
	最大加速度 Maximum acceleration	G	0.37	0.73	1.47	
	滾珠螺桿 Ball screw	基本動額定負荷 Basic dynamic load rating Ca	N	7733	5855	3007
		基本靜額定負荷 Basic static load rating Coa	N	14200	10401	5414
	直線滑軌 Linear Guide	動態水平負載 Dynamic horizontal (100km)	N	18601		
靜態水平負載 Static Horizontal		N	34189			
固定側軸承 Fixed bearing	基本動額定負荷 Basic dynamic load rating Cr	N	8447			
	靜態容許負荷 Static load rating Cor	N	5060			
部品	AC 伺服馬達容量 AC Servo Motor Output	W	400			
	滾珠螺桿外徑 Ball Screw Ø	mm	C7Ø14			
	連軸器 Coupling	mm	10X14			
	原點感應器 Home Sensor	外掛 Outside	T64N2 (NPN+2 米線) (NPN+2M Cable)			

※1 長行程時，會產生螺桿偏擺，需將速度調降 (線速度請參閱尺寸圖下方表格)

During in a long stroke, it causes ball screw deflection, the speed must reduce. (Please refer to the linear velocity from the data sheet below the dimension graph.)

※2 由於各廠牌的馬達性能不同，需適度搭配回升電阻以達到此荷重條件。

Since the motor performance of each brand is different, a regenerative resistor needs to be appropriately matched to achieve this load condition.

容許負載力距表 Allowable Overhang

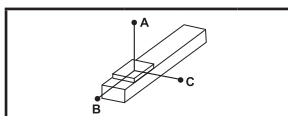

(單位 Unit : mm)

水平安裝 Horizontal Installation		A	B	C
導程 6 Lead	30kg	1900	165	261
	50kg	1080	88	140
	105kg	434	29	47
導程 12 Lead	25kg	780	175	240
	35kg	530	117	160
	85kg	175	33	46
導程 24 Lead	4kg	1400	820	750
	12kg	440	257	235
	40kg	109	60	55

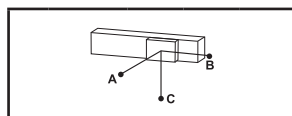

(單位 Unit : mm)

壁掛安裝 Wall Installation		A	B	C
導程 6 Lead	30kg	261	165	1900
	50kg	140	88	1080
	105kg	47	29	434
導程 12 Lead	25kg	240	175	780
	35kg	160	117	530
	85kg	46	33	175
導程 24 Lead	4kg	750	820	1400
	12kg	235	257	440
	40kg	55	60	109

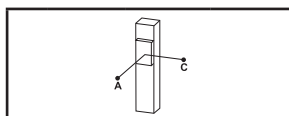

(單位 Unit : mm)

垂直安裝 Vertical Installation		A	C
導程 6 Lead	6kg	335	335
	30kg	180	180
	-	-	-
導程 12 Lead	12kg	400	400
	20kg	240	240
	-	-	-
導程 24 Lead	6kg	460	460
	10kg	275	275
	-	-	-

靜額定扭矩 Static Loading Moment

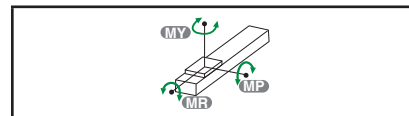

(單位 Unit : N.m)

MY	113
MP	113
MR	227

* 力矩表所表示的數據，代表荷重的重心位置於單一方向容許懸出的長度。
The data represented by the moment table is the center of gravity of the load. The length of the overhang is allowed in a single direction.
* 符合型錄規範的正常使用下，保證壽命為 10000 公里。
Operation life is 10,000km when the product is using under the specified conditions.
* 倒吊使用無法套用標準規範，如有需求請洽詢我司業務。
Data information is not for ceiling-mount inverse use. Contact us for the details if you want to apply ceiling-mount inverse usage.
* 壽命及力矩是以馬達加速減速設定 0.2 秒計算。
The life and torque are calculated by setting the motor acceleration and deceleration for 0.2 seconds.

選配 Options

MM

指定馬達出線方向 Selectable Cable Leading Direction		
代號 Code	說明 Instructions	需參照 Refer to
MW	朝上 Upper side	P.111 ~ P.112
MM	朝下 Bottom side	
ML	朝左 Left side	
MR	朝右 Right side	

CMK

馬達傳動配件追加鍵槽 Additional keyway for motor drive parts				
代號 Code	說明 Instructions			需參照 Refer to
	追加鍵槽 Keyway Groove	馬達位置 Motor Position	出貨型式 Shipment Type	
CMK	單邊 (限定馬達側) Single (Limited to the motor side)	BC	鍵槽式聯軸器 Keyway Coupling	P.113 ~ P.115
		BL/BR/BM	鍵槽式皮帶輪 Keyway Belt Pulley	
SKY	雙邊 Double	BC	鍵槽式聯軸器 Keyway Coupling	
		BL/BR/BM	鍵槽式皮帶輪 Keyway Belt Pulley	
SKN	雙邊 Double	BC	無聯軸器 (請自行購買安裝) Without Coupling (Please purchase and install by yourself)	
		BL/BR/BM	無馬達端皮帶輪 (請自行購買安裝) Without Belt Pulley (Please purchase and install by yourself)	

GLTH Series

- GLTH3
- GLTH5
- GLTH8
- GLTH12
- GLTH5D
- GLTH8D**
- GLMH5
- GLMH8
- GLTH5M
- GLTH8M



Download at www.toyorobot.com

BC 馬達外露 Motor Exposed

單位 Unit : mm

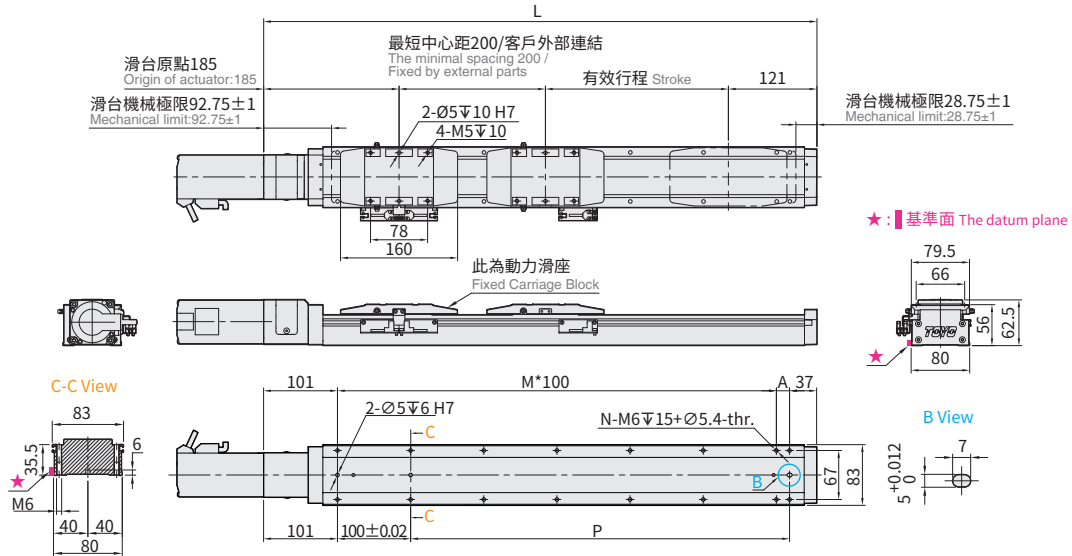

BM 馬達下折 Motor Bottom Side

單位 Unit : mm

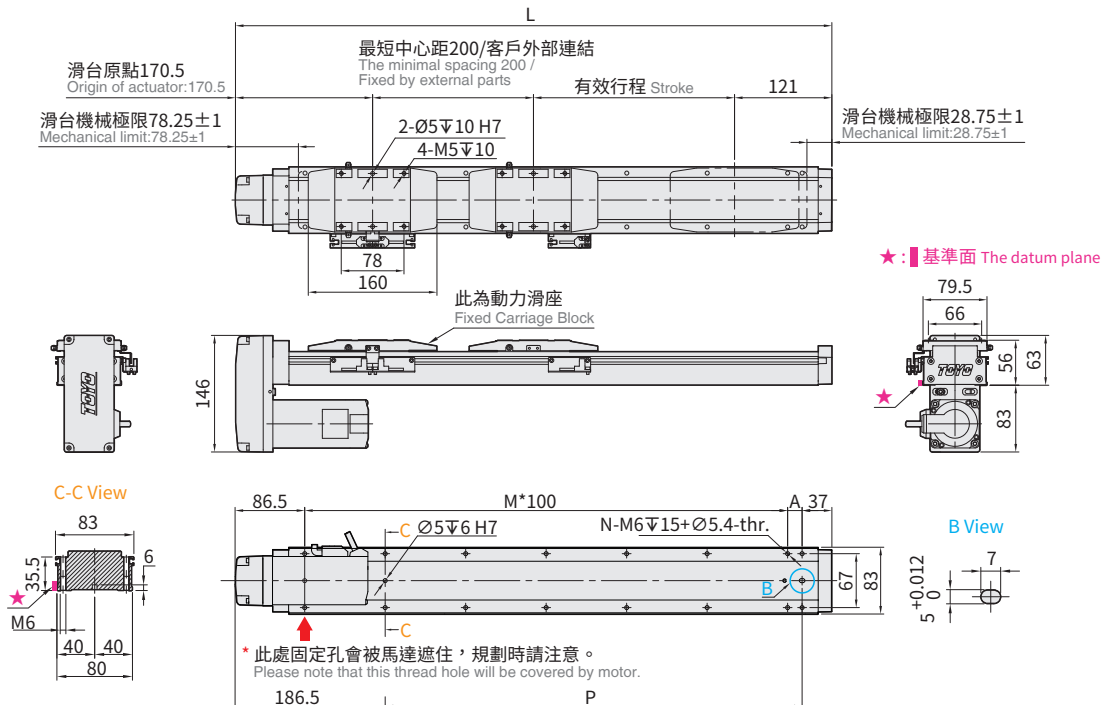

有效行程 Stroke	50 ^{±1}	100	150	200	250	300	350	400	450	500	550	600	650	700	750	800	850	900	950	1000	1050	
極限行程 Limit Stroke (±1)	74.5	124.5	174.5	224.5	274.5	324.5	374.5	424.5	474.5	524.5	574.5	624.5	674.5	724.5	774.5	824.5	874.5	924.5	974.5	1024.5	1074.5	
L	BC	556	606	656	706	756	806	856	906	956	1006	1056	1106	1156	1206	1256	1306	1356	1406	1456	1506	1556
	BM	541.5	591.5	641.5	691.5	741.5	791.5	841.5	891.5	941.5	991.5	1041.5	1091.5	1141.5	1191.5	1241.5	1291.5	1341.5	1391.5	1441.5	1491.5	1541.5
A	18	68	18	68	18	68	18	68	18	68	18	68	18	68	18	68	18	68	18	68	18	68
M	4	4	5	5	6	6	7	7	8	8	9	9	10	10	11	11	12	12	13	13	14	14
N	12	12	14	14	16	16	18	18	20	20	22	22	24	24	26	26	28	28	30	30	32	32
P	BC	318	368	418	468	518	568	618	668	718	768	818	868	918	968	1018	1068	1118	1168	1218	1268	1318
	BM	3.89	4.19	4.49	4.78	5.08	5.37	5.67	5.97	6.27	6.56	6.86	7.15	7.45	7.75	8.04	8.34	8.64	8.93	9.23	9.53	9.82
KG	BC	4.27	4.56	4.86	5.15	5.45	5.75	6.04	6.34	6.64	6.93	7.23	7.53	7.82	8.12	8.41	8.71	9.01	9.3	9.6	9.9	10.19
	BM	360	350	310	270	240	210	190	170	160	140	130	120	110	100	90	80	70	60	50	40	30
線速度 Linear Speed mm/s	導程 Lead 6																					
	導程 Lead 12																					
	導程 Lead 24																					

*1 行程 50 時，因本體上鎖式固定孔會被滑座遮住，僅能使用 4 支螺絲固定，建議客戶本體使用下鎖式固定孔鎖附。When the stroke is 50mm, if fixing the body from the top to the bottom, the fixing hole will be blocked by slider and only can be uses 4 screws to fix; as a result, suggest that fixing actuator body from the bottom to the top.



Download at www.toyorobot.com

BL 馬達左折 Motor Left Side

單位 Unit : mm

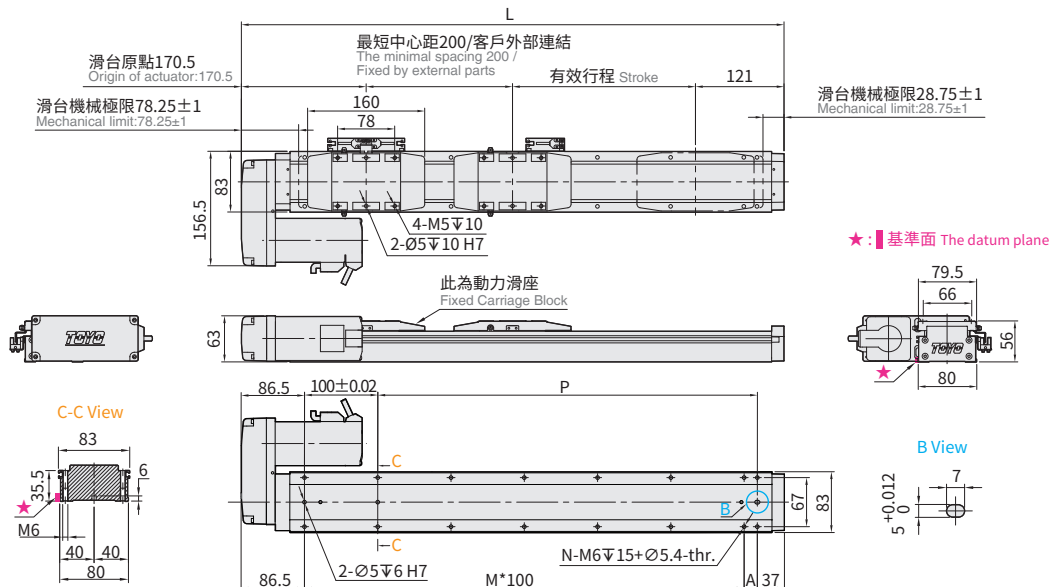

BR 馬達右折 Motor Right Side

單位 Unit : mm

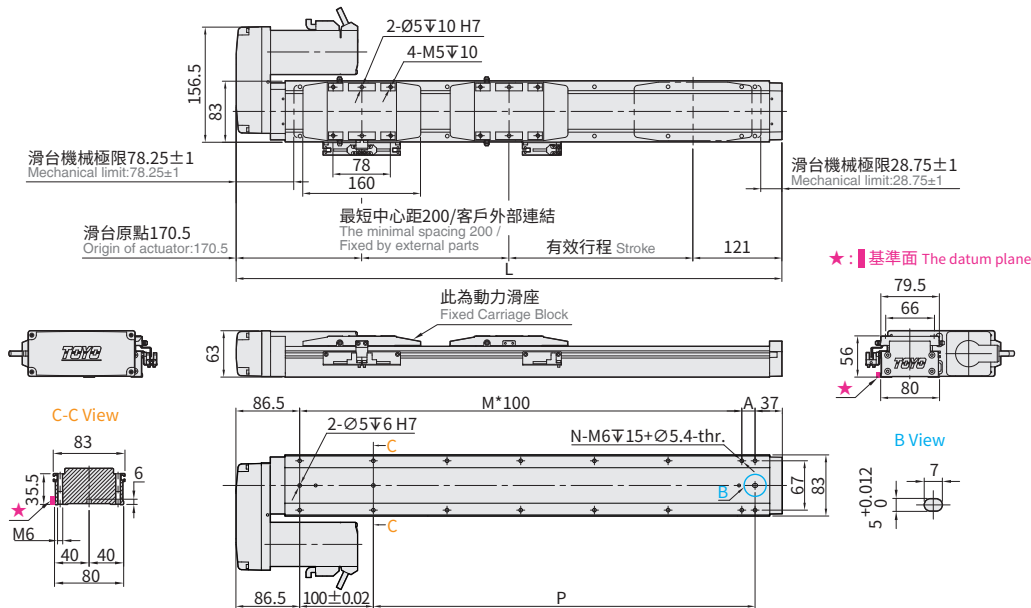

有效行程 Stroke	50 ^{±1}	100	150	200	250	300	350	400	450	500	550	600	650	700	750	800	850	900	950	1000	1050
極限行程 Limit Stroke (±1)	74.5	124.5	174.5	224.5	274.5	324.5	374.5	424.5	474.5	524.5	574.5	624.5	674.5	724.5	774.5	824.5	874.5	924.5	974.5	1024.5	1074.5
L	541.5	591.5	641.5	691.5	741.5	791.5	841.5	891.5	941.5	991.5	1041.5	1091.5	1141.5	1191.5	1241.5	1291.5	1341.5	1391.5	1441.5	1491.5	1541.5
A	18	68	18	68	18	68	18	68	18	68	18	68	18	68	18	68	18	68	18	68	18
M	4	4	5	5	6	6	7	7	8	8	9	9	10	10	11	11	12	12	13	13	14
N	12	12	14	14	16	16	18	18	20	20	22	22	24	24	26	26	28	28	30	30	32
P	318	368	418	468	518	568	618	668	718	768	818	868	918	968	1018	1068	1118	1168	1218	1268	1318
KG	4.27	4.56	4.86	5.15	5.45	5.75	6.04	6.34	6.64	6.93	7.23	7.53	7.82	8.12	8.41	8.71	9.01	9.3	9.6	9.9	10.19
線速度 Linear Speed mm/s	導程 Lead 6	360																			
	導程 Lead 12	720																			
	導程 Lead 24	1440																			

※1行程50時，因本體上鎖式固定孔會被滑座遮住，僅能使用4支螺絲固定，建議客戶本體使用下鎖式固定孔鎖附。When the stroke is 50mm, if fixing the body from the top to the bottom, the fixing hole will be blocked by slider (and only can use 4 screws to fix), as a result, suggest that fixing actuator body from the bottom to the top.

應用例
Application

一般/螺桿仕様
GLTH

一般/皮帶仕様
ETB / M

無塵/螺桿仕様
GCH / ECH

無塵/皮帶仕様
ECB

直交連結
XYGT / XYTH / XYTB

參考資料
Reference

GLTH Series

GLTH3

GLTH5

GLTH8

GLTH12

GLTH5D

GLTH8D

GLMH5

GLMH8

GLTH5M

GLTH8M

GLMH5 單軸 /1-axis

▶ 軌道內嵌
Integrated Linear Bearing

▶ 螺桿驅動
Ball Screw Drive

精度
±0.005
mm



最大行程
Maximum Stroke 1000mm

最高速度
Maximum Speed 1200mm/s

馬達容量
Motor Output 100W

最大可搬重量
Max Payload 30kg

型號表示方式 Ordering Method

GLMH5 - L2 - 100 - BC - M10B - C4N5 - 參照右頁
Refer to the right page. - 0001

本體型號
Model

行程^{*1}
Stroke

50-1000mm
50間隔 50 mm Pitch

選配
Options

特注式樣
Customization Order No.

螺桿導程
Ball Screw Lead

2	2mm
6	6mm
12	12mm
20	20mm

馬達位置
Motor Position

BC	馬達外露 Motor Exposed
BM	馬達下折 Motor Bottom Side
BL	馬達左折 Motor Left Side
BR	馬達右折 Motor Right Side

馬達廠牌、功率
Motor Brand · Power Output

M	三菱 Mitsubishi	05	-	B ^{*2}
P	松下 Panasonic	10	100W	
Y	安川 Yaskawa	20	-	
T	台達 Delta	40	-	

原點感應器
Home Sensor

外掛型 Out Side	
C	馬達側 Motor Side
D	反馬達側 Opposite Motor Side
	無 SENSOR No Sensor
E	無 SENSOR No Sensor

端點極限感應器
Limit Sensor

外掛型 Out Side	
3	1只 1 Pc
4	2只 2 Pcs
6	3只 3 Pcs
7	4只 4 Pcs
8	5只 5 Pcs
9	6只 6 Pcs
	無 SENSOR No Sensor
5	無 SENSOR No Sensor

輸出方式&線長
Output type & Cable length

N5	NPN+5米線 NPN+5M Cable
P2	PNP+2米線 PNP+2M Cable
P5	PNP+5米線 PNP+5M Cable
-	NPN+2米線 NPN+2M Cable

^{*1} 選擇行程50時，光電使用有以下限制：When the stroke is 50mm, the sensor installation has the following restrictions:

馬達方向 BC/BM：1.原點與極限需放置於不同側。2.滑座左右兩側皆需安裝感應片。Motor Direction BC/BM 1.Home sensor and limit sensor has to be installed on the different side of body. 2.Both sides of slider need to install the sensor trigger device.
馬達方向 BL/BR：1.原點+極限感應器最數量最多2只(僅能選用C3/D3/E3/E4/E5)。Motor Direction BL/BR 1.Home + limit sensors is 2 maximum (only C3/D3/E3/E4/E5 can be selected)

^{*2} 馬達若無煞車則不表示。If Motor No Brake, No Description.

基本仕様 Specification

性能	位置重複精度 Repeatability	mm	±0.005				
	螺桿導程 Lead	mm	2	6	12	20	
	最高轉速 Maximum Rotating speed	rpm	3600	3600	3600	3600	
	最高速度 Maximum linear speed ^{※1}	mm/s	120	300	720	1200	
	最大可搬重量 ^{※2} Maximum Payload	水平使用 Horizontal	kg	30	25	22	10
		垂直使用 Vertical	kg	10	6	4	3
	定格推力 Rated Thrust	N	854	285	142	85	
	標準行程 Stroke (increments)	mm	50-1000mm / 50 間隔 (50 increments)				
	最大加速度 Maximum acceleration	G	0.12	0.37	0.73	1.22	
	滾珠螺桿 Ball screw	基本動額定負荷 Basic dynamic load rating Ca	N	2270	2243	1436	1384
基本靜額定負荷 Basic static load rating Coa		N	4836	3959	2441	2535	
直線滑軌 Linear Guide	動態水平負載 Dynamic horizontal (100km)	N	6563				
	靜態水平負載 Static Horizontal	N	13587				
固定側軸承 Fixed bearing	基本動額定負荷 Basic dynamic load rating Cr	N	5361				
	靜態容許負荷 Static load rating Cor	N	2880				
部品	AC 伺服馬達容量 AC Servo Motor Output	W	100				
	滾珠螺桿外徑 Ball Screw Ø	mm	C7Ø10				
	連軸器 Coupling	mm	7X8				
	原點感應器 Home Sensor	外掛 Outside	T64N2 (NPN+2 米線) (NPN+2M Cable)				

※1 長行程時，會產生螺桿偏擺，需將速度調降 (線速度請參閱尺寸圖下方表格)

During in a long stroke, it causes ballscrew deflection, the speed must reduce. (Please refer to the linear velocity from the data sheet below the dimension graph.)

※2 由於各廠牌的馬達性能不同，需適度搭配回升電阻以達到此荷重條件。

Since the motor performance of each brand is different, a regenerative resistor needs to be appropriately matched to achieve this load condition.

容許負載力距表 Allowable Overhang

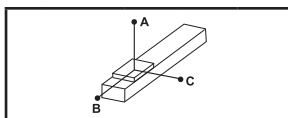

(單位 Unit: mm)

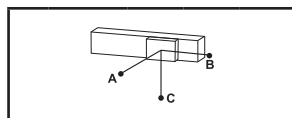

(單位 Unit: mm)

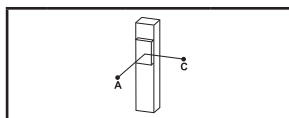

(單位 Unit: mm)

水平安裝 Horizontal Installation		A	B	C
導程 2 Lead	10kg	2500	157	250
	20kg	1120	70	112
	30kg	650	41	65
導程 6 Lead	10kg	1400	122	184
	20kg	650	52	79
	25kg	490	38	57
導程 12 Lead	8kg	590	132	175
	10kg	460	103	135
	22kg	185	37	49
導程 20 Lead	3kg	656	300	303
	6kg	314	141	144
	10kg	177	78	79

壁掛安裝 Wall Installation		A	B	C
導程 2 Lead	10kg	250	157	2500
	20kg	112	70	1120
	30kg	65	41	650
導程 6 Lead	10kg	184	122	1400
	20kg	79	52	650
	25kg	57	38	490
導程 12 Lead	8kg	175	132	590
	10kg	135	103	460
	22kg	49	37	185
導程 20 Lead	3kg	303	300	656
	6kg	144	141	314
	10kg	79	78	177

垂直安裝 Vertical Installation		A	C
導程 2 Lead	5kg	346	346
	10kg	173	173
	-	-	-
導程 6 Lead	3kg	463	463
	6kg	231	231
	-	-	-
導程 12 Lead	2.5kg	465	465
	4kg	292	292
	-	-	-
導程 20 Lead	1.5kg	555	555
	3g	278	278
	-	-	-

靜額定扭矩 Static Loading Moment

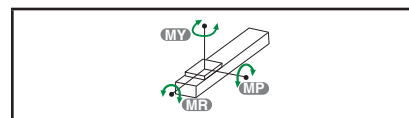

(單位 Unit: N.m)

MY	73
MP	73
MR	115

* 力矩表所表示的數據，代表荷重的重心位置於單一方向容許懸出的長度。
The data represented by the moment table is the center of gravity of the load. The length of the overhang is allowed in a single direction.

* 符合型錄規範的正常使用下，保證壽命為 10000 公里。

Operation life is 10,000km when the product is using under the specified conditions.

* 倒吊使用無法套用標準規範，如有需求請洽詢我司業務。

Data information is not for ceiling-mount inverse use. Contact us for the details if you want to apply ceiling-mount inverse usage.

* 壽命及力矩是以馬達加減速設定 0.2 秒計算。

The life and torque are calculated by setting the motor acceleration and deceleration for 0.2 seconds.

選配 Options

MM

指定馬達出線方向 Selectable Cable Leading Direction		
代號 Code	說明 Instructions	需參照 Refer to
MW	朝上 Upper side	P.111 ~ P.112
MM	朝下 Bottom side	
ML	朝左 Left side	
MR	朝右 Right side	

CMK

馬達傳動配件追加鍵槽 Additional keyway for motor drive parts				
代號 Code	說明 Instructions			需參照 Refer to
	追加鍵槽 Keyway Groove	馬達位置 Motor Position	出貨型式 Shipment Type	
CMK	單邊 (限定馬達側) Single (Limited to the motor side)	BC	鍵槽式聯軸器 Keyway Coupling	P.113 ~ P.115
		BL/BR/BM	鍵槽式皮帶輪 Keyway Belt Pulley	
SKY	雙邊 Double	BC	鍵槽式聯軸器 Keyway Coupling	
		BL/BR/BM	鍵槽式皮帶輪 Keyway Belt Pulley	
SKN	雙邊 Double	BC	無聯軸器 (請自行購買安裝) Without Coupling (Please purchase and install by yourself)	
		BL/BR/BM	無馬達端皮帶輪 (請自行購買安裝) Without Belt Pulley (Please purchase and install by yourself)	

GLTH Series

- GLTH3
- GLTH5
- GLTH8
- GLTH12
- GLTH5D
- GLTH8D
- GLMH5
- GLMH8
- GLTH5M
- GLTH8M

GLMH5 單軸 /1-axis

▶ 軌道內嵌
Integrated Linear Bearing

▶ 螺桿驅動
Ball Screw Drive



• Download at www.toyorobot.com •

BC 馬達外露 Motor Exposed

單位 Unit : mm

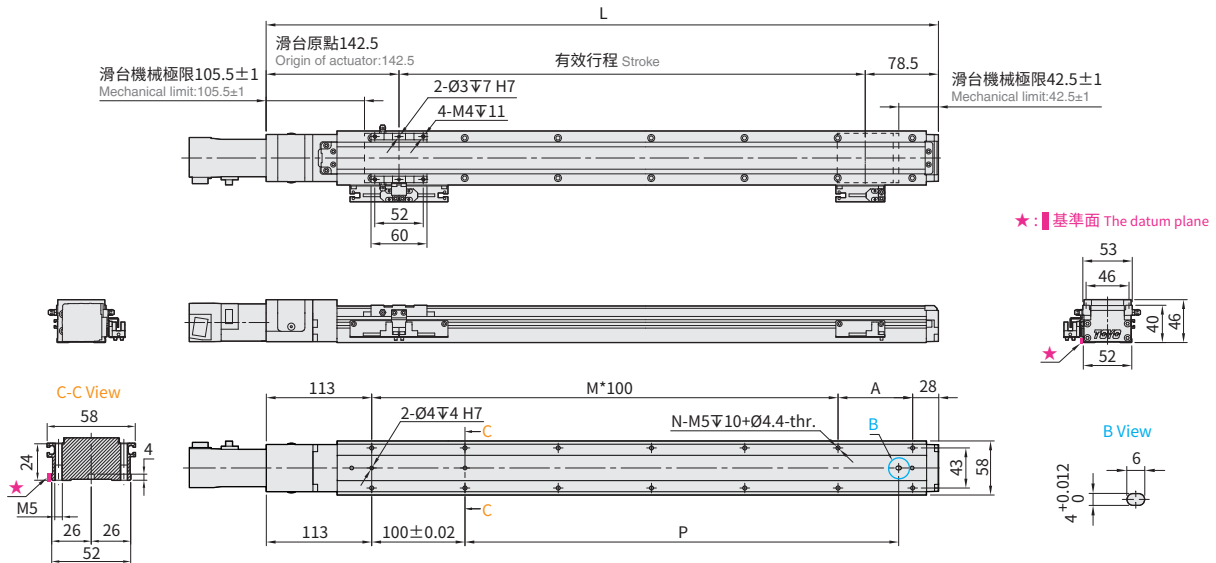

BM 馬達下折 Motor Bottom Side

單位 Unit : mm

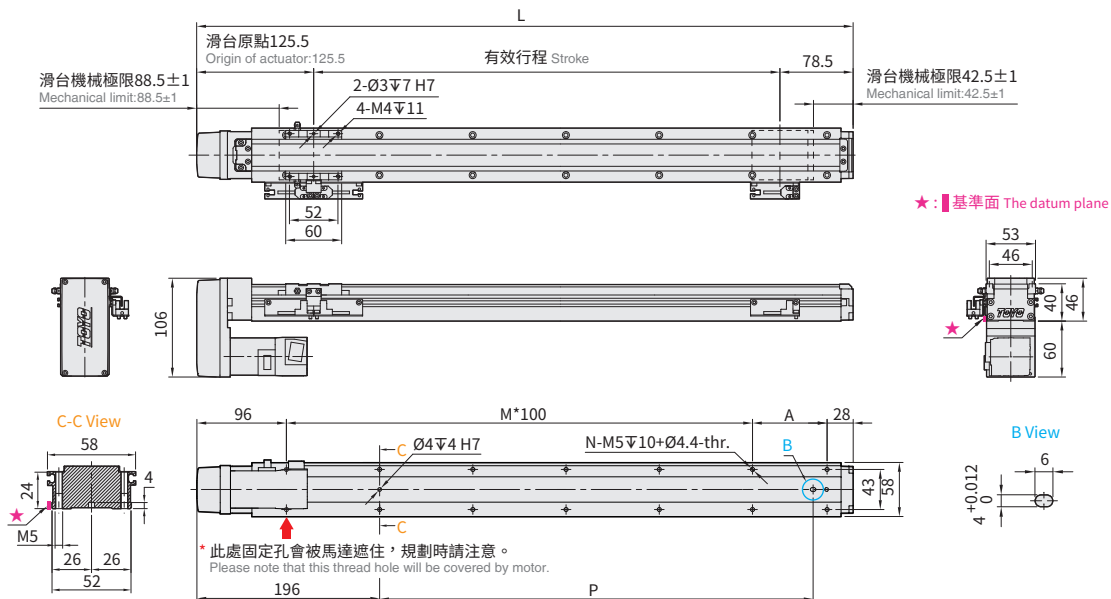

有效行程 Stroke	50 ^{±1}	100	150	200	250	300	350	400	450	500	550	600	650	700	750	800	850	900	950	1000		
極限行程 Limit Stroke (±1)	63	113	163	213	263	313	363	413	463	513	563	613	663	713	763	813	863	913	963	1013		
L	BC	271	321	371	421	471	521	571	621	671	721	771	821	871	921	971	1021	1071	1121	1171	1221	
	BM	254	304	354	404	454	504	554	604	654	704	754	804	854	904	954	1004	1054	1104	1154	1204	
A	30	80	30	80	30	80	30	80	30	80	30	80	30	80	30	80	30	80	30	80	30	80
M	1	1	2	2	3	3	4	4	5	5	6	6	7	7	8	8	9	9	10	10	10	10
N	6	6	8	8	10	10	12	12	14	14	16	16	18	18	20	20	22	22	24	24	24	24
P	15	65	115	165	215	265	315	365	415	465	515	565	615	665	715	765	815	865	915	965	965	965
KG	BC	1.07	1.2	1.33	1.45	1.58	1.7	1.83	1.96	2.08	2.21	2.34	2.46	2.59	2.72	2.84	2.97	3.09	3.22	3.35	3.47	3.47
	BM	1.17	1.3	1.43	1.55	1.68	1.8	1.93	2.06	2.18	2.31	2.44	2.56	2.69	2.82	2.94	3.07	3.19	3.32	3.45	3.57	3.57
線速度 Linear Speed mm/s	導程 Lead 2					120					110	90	80	70	63	53	50	43	40	36		
	導程 Lead 6					360					330	270	240	210	190	160	150	130	120	110		
	導程 Lead 12					720					660	540	480	420	380	320	300	260	240	220		
	導程 Lead 20					1200					1100	900	800	700	630	533	500	430	400	367		

※1行程50時，因本體上鎖式固定孔會被滑座遮住，僅能使用4支螺絲固定，建議客戶本體使用下鎖式固定孔鎖附。When the stroke is 50mm, if fixing the body from the top to the bottom, the fixing hole will be blocked by slider and only can be uses 4 screws to fix; as a result, suggest that fixing actuator body from the bottom to the top.



Download at www.toyorobot.com

BL 馬達左折 Motor Left Side

單位 Unit : mm

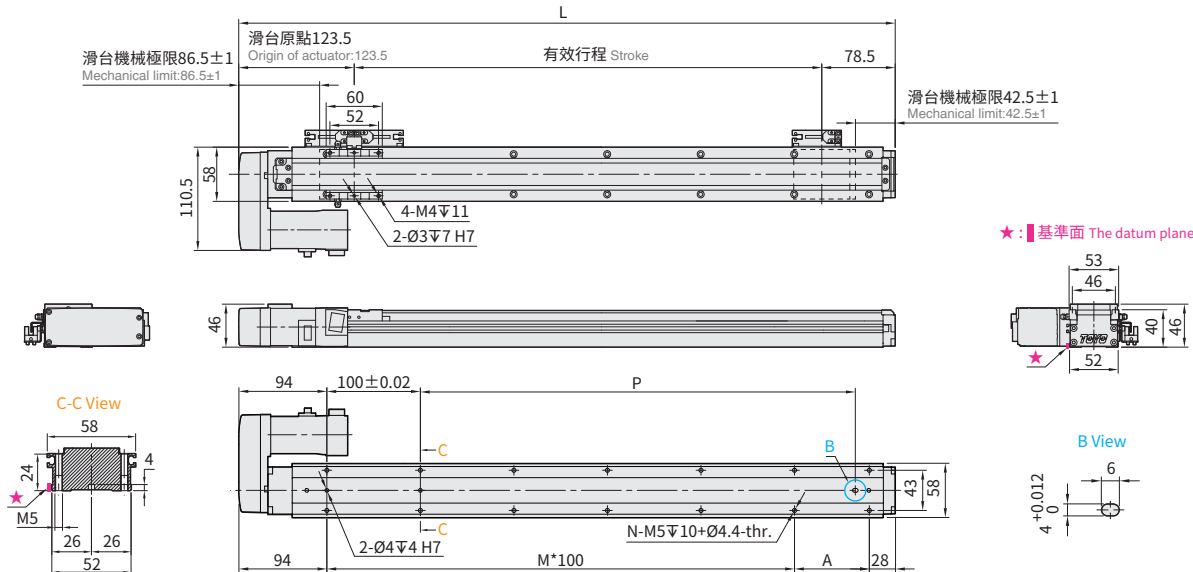

BR 馬達右折 Motor Right Side

單位 Unit : mm

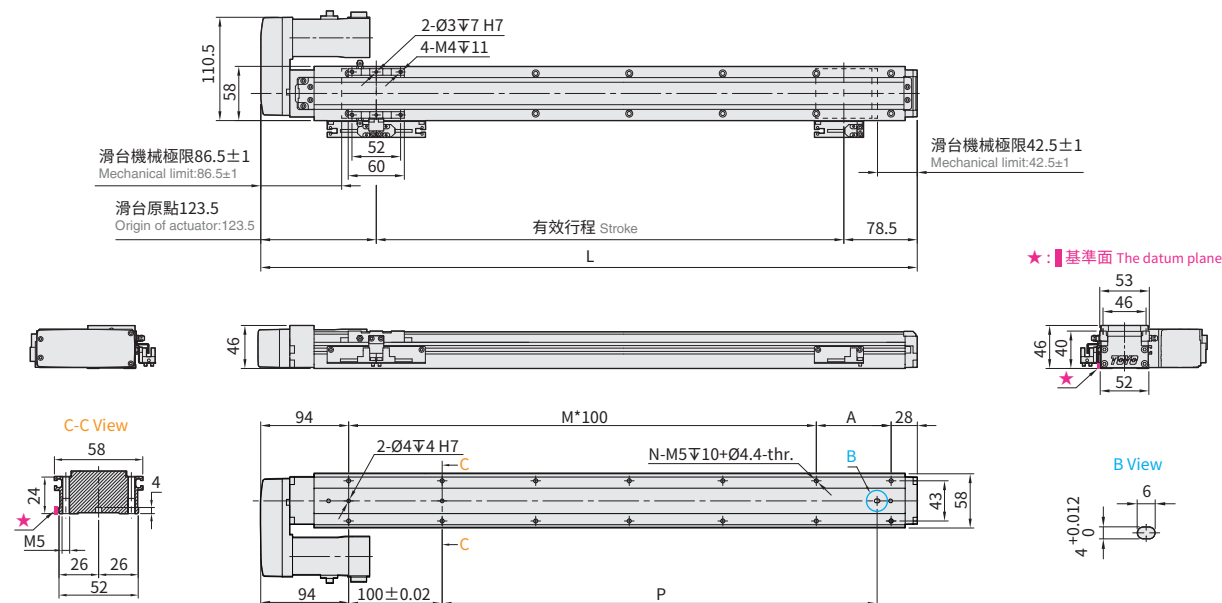

有效行程 Stroke	50 ^{±1}	100	150	200	250	300	350	400	450	500	550	600	650	700	750	800	850	900	950	1000
極限行程 Limit Stroke (±1)	63	113	163	213	263	313	363	413	463	513	563	613	663	713	763	813	863	913	963	1013
L	252	302	352	402	452	502	552	602	652	702	752	802	852	902	952	1002	1052	1102	1152	1202
A	30	80	30	80	30	80	30	80	30	80	30	80	30	80	30	80	30	80	30	80
M	1	1	2	2	3	3	4	4	5	5	6	6	7	7	8	8	9	9	10	10
N	6	6	8	8	10	10	12	12	14	14	16	16	18	18	20	20	22	22	24	24
P	15	65	115	165	215	265	315	365	415	465	515	565	615	665	715	765	815	865	915	965
KG	1.17	1.3	1.43	1.55	1.68	1.8	1.93	2.06	2.18	2.31	2.44	2.56	2.69	2.82	2.94	3.07	3.19	3.32	3.45	3.57
線速度 Linear Speed mm/s	導程 Lead 2										110	90	80	70	63	53	50	43	40	36
	導程 Lead 6										330	270	240	210	190	160	150	130	120	110
	導程 Lead 12										660	540	480	420	380	320	300	260	240	220
	導程 Lead 20										1100	900	800	700	630	533	500	430	400	367

※1 行程 50 時，因本體上鎖式固定孔會被滑座遮住，僅能使用 4 支螺絲固定，建議客戶本體使用下鎖式固定孔鎖附。When the stroke is 50mm, if fixing the body from the top to the bottom, the fixing hole will be blocked by slider and only can be uses 4 screws to fix,as a result, suggest that fixing actuator body from the bottom to the top.

應用例
Application

一般 / 螺桿仕様
GLTH

一般 / 皮帶仕様
ETB / M

無塵 / 螺桿仕様
GCH / ECH

無塵 / 皮帶仕様
ECB

直交連結
XYGT / XYTH / XYTB

參考資料
Reference

GLTH Series

GLTH3

GLTH5

GLTH8

GLTH12

GLTH5D

GLTH8D

GLMH5

GLMH8

GLTH5M

GLTH8M

GLMH8 單軸 /1-axis

▶ 軌道內嵌
Integrated Linear Bearing

▶ 螺桿驅動
Ball Screw Drive

精度
±0.005 mm



最大行程
Maximum Stroke 1250mm

最高速度
Maximum Speed 1440mm/s

馬達容量
Motor Output 200W

最大可搬重量
Max Payload 80kg

型號表示方式 Ordering Method

GLMH8 - L6 - 100 - BC - M20B - C4N5 - 參照右頁 - 0001

本體型號
Model

行程^{*1}
Stroke

50-1250mm
50間隔 50 mm Pitch

馬達位置
Motor Position

BC	馬達外露 Motor Exposed
BM	馬達下折 Motor Bottom Side
BL	馬達左折 Motor Left Side
BR	馬達右折 Motor Right Side

馬達廠牌、功率
Motor Brand · Power Output

M	三菱 Mitsubishi	05	-	B ^{*2}
P	松下 Panasonic	10	-	
Y	安川 Yaskawa	20	200W	
T	台達 Delta	40	-	

原點感應器
Home Sensor

外掛型 Out Side	
C	馬達側 Motor Side
D	反馬達側 Opposite Motor Side
無 SENSOR No Sensor	
E	無 SENSOR No Sensor

端點極限感應器
Limit Sensor

外掛型 Out Side	
3	1只 1 Pc
4	2只 2 Pcs
6	3只 3 Pcs
7	4只 4 Pcs
8	5只 5 Pcs
9	6只 6 Pcs
無 SENSOR No Sensor	
5	無 SENSOR No Sensor

選配
Options

特注式樣
Customization Order No.

螺桿導程
Ball Screw Lead

6	6mm
12	12mm
24	24mm

輸出方式&線長
Output type & Cable length

N5	NPN+5米線 NPN+5M Cable
P2	PNP+2米線 PNP+2M Cable
P5	PNP+5米線 PNP+5M Cable
-	NPN+2米線 NPN+2M Cable

*1 選擇行程50時，光電使用有以下限制：When the stroke is 50mm, the sensor installation has the following restrictions:

馬達方向 BC/BM：1.原點與極限需放置於不同側。2.滑座左右兩側皆需安裝感應片。Motor Direction BC/BM 1.Home sensor and limit sensor has to be installed on the different side of body. 2.Both sides of slider need to install the sensor trigger device.
馬達方向 BL/BR：1.原點+極限感應器最數量最多2只(僅能選用C3/D3/E3/E4/E5)。Motor Direction BL/BR 1.Home + limit sensor is 2 maximum (only C3/D3/E3/E4/E5 can be selected)

*2 馬達若無煞車則不表示。If Motor No Brake, No Description.

基本仕様 Specification

性能	位置重複精度 Repeatability	mm	±0.005			
	螺桿導程 Lead	mm	6	12	24	
	最高轉速 Maximum Rotating speed	rpm	3600	3600	3600	
	最高速度 Maximum linear speed ^{※1}	mm/s	360	720	1440	
	最大可搬重量 ^{※2} Maximum Payload	水平使用 Horizontal	kg	80	60	40
		垂直使用 Vertical	kg	15	8	5
	定格推力 Rated Thrust	N	569	284	142	
	標準行程 Stroke (increments)	mm	50-1250mm / 50 間隔 (50 increments)			
	最大加速度 Maximum acceleration	G	0.37	0.73	1.47	
	滾珠螺桿 Ball screw	基本動額定負荷 Basic dynamic load rating Ca	N	7733	5855	3007
基本靜額定負荷 Basic static load rating Coa		N	14200	10401	5414	
直線滑軌 Linear Guide	動態水平負載 Dynamic horizontal (100km)	N	18601			
	靜態水平負載 Static Horizontal	N	34189			
固定側軸承 Fixed bearing	基本動額定負荷 Basic dynamic load rating Cr	N	8447			
	靜態容許負荷 Static load rating Cor	N	5060			
部品	AC 伺服馬達容量 AC Servo Motor Output	W	200			
	滾珠螺桿外徑 Ball Screw Ø	mm	C7Ø14			
	連軸器 Coupling	mm	10X14 /11 ^{※3}			
	原點感應器 Home Sensor	外掛 Outside	T64N2 (NPN+2 米線) (NPN+2M Cable)			

※1 長行程時，會產生螺桿偏擺，需將速度調降 (線速度請參閱尺寸圖下方表格)
During in a long stroke, it causes ballscrew deflection, the speed must reduce. (Please refer to the linear velocity from the data sheet below the dimension graph.)
※2 由於各廠牌的馬達性能不同，需適度搭配回升電阻以達到此荷重條件。
Since the motor performance of each brand is different, a regenerative resistor needs to be appropriately matched to achieve this load condition.
※3 使用 Panasonic 200W 馬達時，馬達軸心為 Ø11；其他廠牌，馬達軸心為 Ø14。Motor (200W) Shaft Diameter: Panasonic: 11mm; Other: 14mm.

容許負載力距表 Allowable Overhang

(單位 Unit: mm)	(單位 Unit: mm)	(單位 Unit: mm)																																																																																																																																															
<table border="1"> <tr><th colspan="4">水平安裝 Horizontal Installation</th></tr> <tr><th>導程 6 Lead</th><th>A</th><th>B</th><th>C</th></tr> <tr><td>35kg</td><td>1600</td><td>139</td><td>220</td></tr> <tr><td>45kg</td><td>1210</td><td>102</td><td>160</td></tr> <tr><td>80kg</td><td>620</td><td>46</td><td>74</td></tr> <tr><th>導程 12 Lead</th><th>A</th><th>B</th><th>C</th></tr> <tr><td>10kg</td><td>2040</td><td>470</td><td>645</td></tr> <tr><td>30kg</td><td>638</td><td>141</td><td>193</td></tr> <tr><td>60kg</td><td>283</td><td>58</td><td>80</td></tr> <tr><th>導程 24 Lead</th><th>A</th><th>B</th><th>C</th></tr> <tr><td>20kg</td><td>253</td><td>145</td><td>133</td></tr> <tr><td>40kg</td><td>109</td><td>60</td><td>55</td></tr> <tr><td>-</td><td>-</td><td>-</td><td>-</td></tr> </table>	水平安裝 Horizontal Installation				導程 6 Lead	A	B	C	35kg	1600	139	220	45kg	1210	102	160	80kg	620	46	74	導程 12 Lead	A	B	C	10kg	2040	470	645	30kg	638	141	193	60kg	283	58	80	導程 24 Lead	A	B	C	20kg	253	145	133	40kg	109	60	55	-	-	-	-	<table border="1"> <tr><th colspan="4">壁掛安裝 Wall Installation</th></tr> <tr><th>導程 6 Lead</th><th>A</th><th>B</th><th>C</th></tr> <tr><td>35kg</td><td>220</td><td>139</td><td>1600</td></tr> <tr><td>45kg</td><td>160</td><td>102</td><td>1210</td></tr> <tr><td>80kg</td><td>74</td><td>46</td><td>620</td></tr> <tr><th>導程 12 Lead</th><th>A</th><th>B</th><th>C</th></tr> <tr><td>10kg</td><td>645</td><td>470</td><td>2040</td></tr> <tr><td>30kg</td><td>193</td><td>141</td><td>638</td></tr> <tr><td>60kg</td><td>80</td><td>58</td><td>283</td></tr> <tr><th>導程 24 Lead</th><th>A</th><th>B</th><th>C</th></tr> <tr><td>20kg</td><td>133</td><td>145</td><td>253</td></tr> <tr><td>40kg</td><td>55</td><td>60</td><td>109</td></tr> <tr><td>-</td><td>-</td><td>-</td><td>-</td></tr> </table>	壁掛安裝 Wall Installation				導程 6 Lead	A	B	C	35kg	220	139	1600	45kg	160	102	1210	80kg	74	46	620	導程 12 Lead	A	B	C	10kg	645	470	2040	30kg	193	141	638	60kg	80	58	283	導程 24 Lead	A	B	C	20kg	133	145	253	40kg	55	60	109	-	-	-	-	<table border="1"> <tr><th colspan="3">垂直安裝 Vertical Installation</th></tr> <tr><th>導程 6 Lead</th><th>A</th><th>C</th></tr> <tr><td>10kg</td><td>535</td><td>535</td></tr> <tr><td>15kg</td><td>360</td><td>360</td></tr> <tr><td>-</td><td>-</td><td>-</td></tr> <tr><th>導程 12 Lead</th><th>A</th><th>C</th></tr> <tr><td>3.5kg</td><td>1380</td><td>1380</td></tr> <tr><td>8kg</td><td>605</td><td>605</td></tr> <tr><td>-</td><td>-</td><td>-</td></tr> <tr><th>導程 24 Lead</th><th>A</th><th>C</th></tr> <tr><td>2kg</td><td>1380</td><td>1380</td></tr> <tr><td>5kg</td><td>556</td><td>556</td></tr> <tr><td>-</td><td>-</td><td>-</td></tr> </table>	垂直安裝 Vertical Installation			導程 6 Lead	A	C	10kg	535	535	15kg	360	360	-	-	-	導程 12 Lead	A	C	3.5kg	1380	1380	8kg	605	605	-	-	-	導程 24 Lead	A	C	2kg	1380	1380	5kg	556	556	-	-	-
水平安裝 Horizontal Installation																																																																																																																																																	
導程 6 Lead	A	B	C																																																																																																																																														
35kg	1600	139	220																																																																																																																																														
45kg	1210	102	160																																																																																																																																														
80kg	620	46	74																																																																																																																																														
導程 12 Lead	A	B	C																																																																																																																																														
10kg	2040	470	645																																																																																																																																														
30kg	638	141	193																																																																																																																																														
60kg	283	58	80																																																																																																																																														
導程 24 Lead	A	B	C																																																																																																																																														
20kg	253	145	133																																																																																																																																														
40kg	109	60	55																																																																																																																																														
-	-	-	-																																																																																																																																														
壁掛安裝 Wall Installation																																																																																																																																																	
導程 6 Lead	A	B	C																																																																																																																																														
35kg	220	139	1600																																																																																																																																														
45kg	160	102	1210																																																																																																																																														
80kg	74	46	620																																																																																																																																														
導程 12 Lead	A	B	C																																																																																																																																														
10kg	645	470	2040																																																																																																																																														
30kg	193	141	638																																																																																																																																														
60kg	80	58	283																																																																																																																																														
導程 24 Lead	A	B	C																																																																																																																																														
20kg	133	145	253																																																																																																																																														
40kg	55	60	109																																																																																																																																														
-	-	-	-																																																																																																																																														
垂直安裝 Vertical Installation																																																																																																																																																	
導程 6 Lead	A	C																																																																																																																																															
10kg	535	535																																																																																																																																															
15kg	360	360																																																																																																																																															
-	-	-																																																																																																																																															
導程 12 Lead	A	C																																																																																																																																															
3.5kg	1380	1380																																																																																																																																															
8kg	605	605																																																																																																																																															
-	-	-																																																																																																																																															
導程 24 Lead	A	C																																																																																																																																															
2kg	1380	1380																																																																																																																																															
5kg	556	556																																																																																																																																															
-	-	-																																																																																																																																															

靜額定扭矩 Static Loading Moment

(單位 Unit: N.m)						
<table border="1"> <tr><th>MY</th><td>137</td></tr> <tr><th>MP</th><td>137</td></tr> <tr><th>MR</th><td>227</td></tr> </table>	MY	137	MP	137	MR	227
MY	137					
MP	137					
MR	227					
<p>* 力矩表所表示的數據，代表荷重的重心位置於單方向容許懸出的長度。 The data represented by the moment table is the center of gravity of the load. The length of the overhang is allowed in a single direction. * 符合型錄規範的正常使用下，保證壽命為 10000 公里。 Operation life is 10,000km when the product is using under the specified conditions. * 倒吊使用無法套用標準規範，如有需求請洽詢我司業務。 Data information is not for ceiling-mount inverse usage. Contact us for the details if you want to apply ceiling-mount inverse usage. * 壽命及力矩是以馬達加減速設定 0.2 秒計算。 The life and torque are calculated by setting the motor acceleration and deceleration for 0.2 seconds.</p>						

選配 Options

MM

指定馬達出線方向 Selectable Cable Leading Direction		
代號 Code	說明 Instructions	需參照 Refer to
MW	朝上 Upper side	P.111 ~ P.112
MM	朝下 Bottom side	
ML	朝左 Left side	
MR	朝右 Right side	

CMK

馬達傳動配件追加鍵槽 Additional keyway for motor drive parts				
代號 Code	說明 Instructions			需參照 Refer to
	追加鍵槽 Keyway Groove	馬達位置 Motor Position	出貨型式 Shipment Type	
CMK	單邊 (限定馬達側) Single (Limited to the motor side)	BC	鍵槽式聯軸器 Keyway Coupling	P.113 ~ P.115
		BL/BR/BM	鍵槽式皮帶輪 Keyway Belt Pulley	
SKY	雙邊 Double	BC	鍵槽式聯軸器 Keyway Coupling	
		BL/BR/BM	鍵槽式皮帶輪 Keyway Belt Pulley	
SKN	雙邊 Double	BC	無聯軸器 (請自行購買安裝) Without Coupling (Please purchase and install by yourself)	
		BL/BR/BM	無馬達端皮帶輪 (請自行購買安裝) Without Belt Pulley (Please purchase and install by yourself)	

GLTH Series

- GLTH3
- GLTH5
- GLTH8
- GLTH12
- GLTH5D
- GLTH8D
- GLMH5
- GLMH8**
- GLTH5M
- GLTH8M



Download at www.toyorobot.com

BC 馬達外露 Motor Exposed

單位 Unit : mm

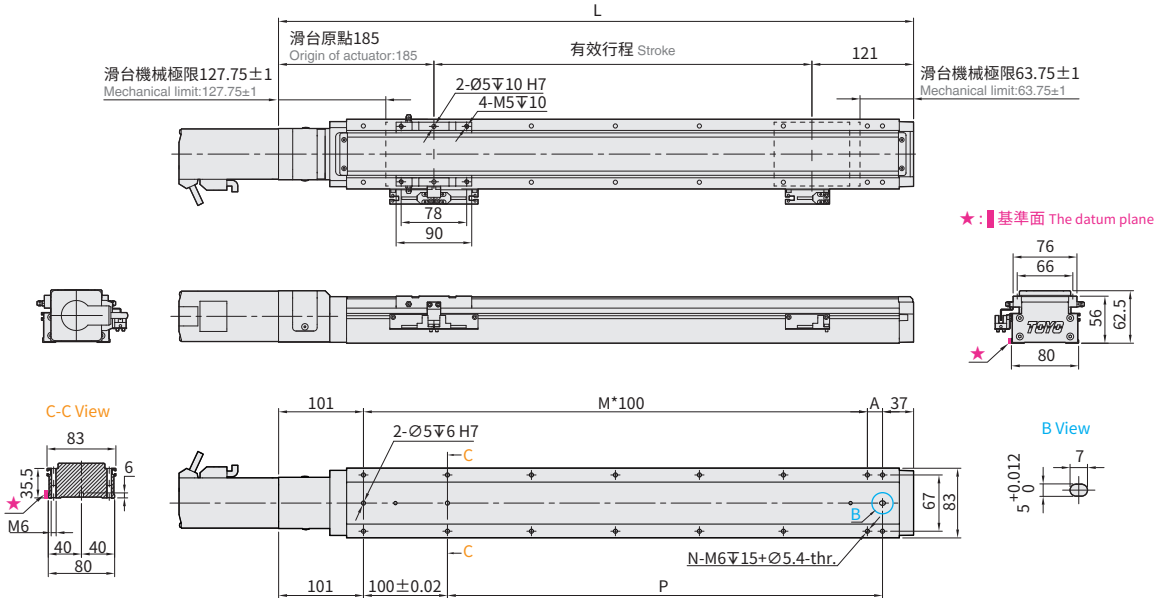

BM 馬達下折 Motor Bottom Side

單位 Unit : mm

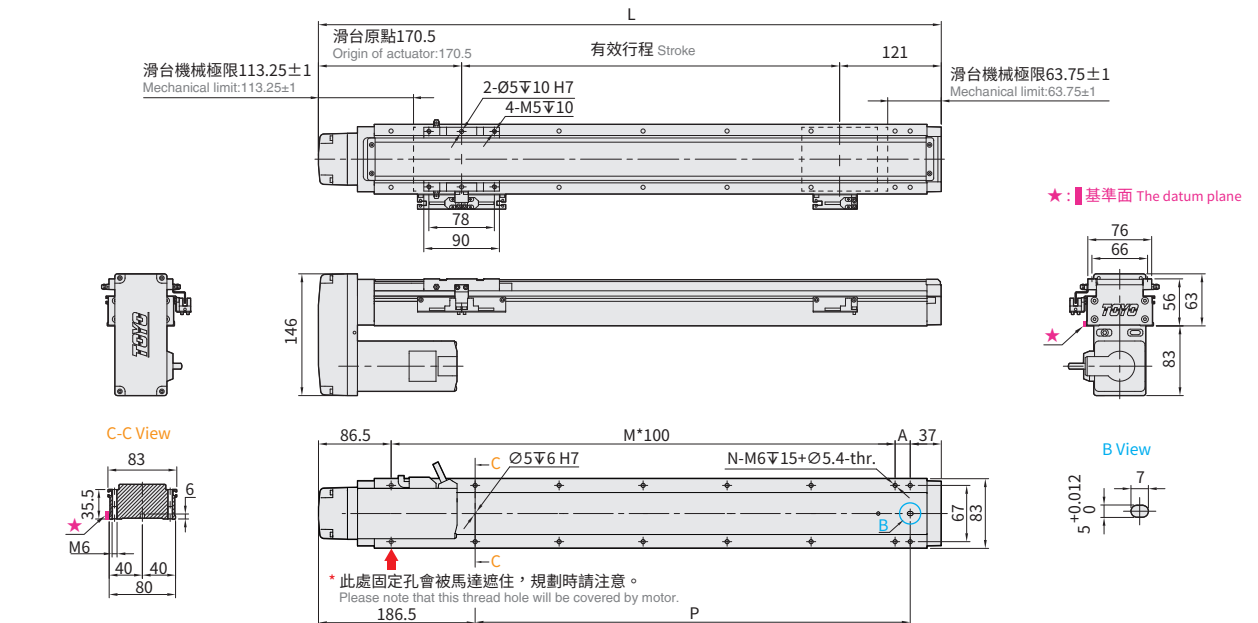

有效行程 Stroke	50 ⁻¹	100	150	200	250	300	350	400	450	500	550	600	650	700	750	800	850	900	950	1000	1050	1100	1150	1200	1250	
極限行程 Limit Stroke (±1)	74.5	124.5	174.5	224.5	274.5	324.5	374.5	424.5	474.5	524.5	574.5	624.5	674.5	724.5	774.5	824.5	874.5	924.5	974.5	1024.5	1074.5	1124.5	1174.5	1224.5	1274.5	
L	BC	356	406	456	506	556	606	656	706	756	806	856	906	956	1006	1056	1106	1156	1206	1256	1306	1356	1406	1456	1506	1556
	BM	341.5	391.5	441.5	491.5	541.5	591.5	641.5	691.5	741.5	791.5	841.5	891.5	941.5	991.5	1041.5	1091.5	1141.5	1191.5	1241.5	1291.5	1341.5	1391.5	1441.5	1491.5	1541.5
A	18	68	18	68	18	68	18	68	18	68	18	68	18	68	18	68	18	68	18	68	18	68	18	68	18	68
M	2	2	3	3	4	4	5	5	6	6	7	7	8	8	9	9	10	10	11	11	12	12	13	13	14	
N	8	8	10	10	12	12	14	14	16	16	18	18	20	20	22	22	24	24	26	26	28	28	30	30	32	
P	118	168	218	268	318	368	418	468	518	568	618	668	718	768	818	868	918	968	1018	1068	1118	1168	1218	1268	1318	
KG	BC	2.37	2.67	2.96	3.26	3.55	3.85	4.15	4.44	4.74	5.02	5.33	5.63	5.93	6.22	6.52	6.81	7.11	7.41	7.7	8	8.3	8.59	8.89	9.19	9.48
	BM	2.74	3.04	3.33	3.63	3.93	4.22	4.52	4.81	5.11	5.41	5.7	6	6.3	6.59	6.89	7.19	7.48	7.78	8.07	8.37	8.67	8.96	9.26	9.56	9.85
線速度 Linear Speed mm/s	導程 Lead 6	360										350	310	270	240	210	190	170	160	140	130	120	110	100	90	
	導程 Lead 12	720										700	620	540	480	420	380	340	320	280	260	240	220	200	180	
	導程 Lead 24	1440										1400	1240	1080	960	840	760	680	640	560	520	480	440	400	360	

* 1 行程 50 時，因本體上鎖式固定孔會被滑座遮住，僅能使用 4 支螺絲固定，建議客戶本體使用下鎖式固定孔鎖附。 When the stroke is 50mm, if fixing the body from the top to the bottom, the fixing hole will be blocked by slider and only can be uses 4 screws to fix; as a result, suggest that fixing actuator body from the bottom to the top.



Download at www.toyorobot.com

BL 馬達左折 Motor Left Side

單位 Unit : mm

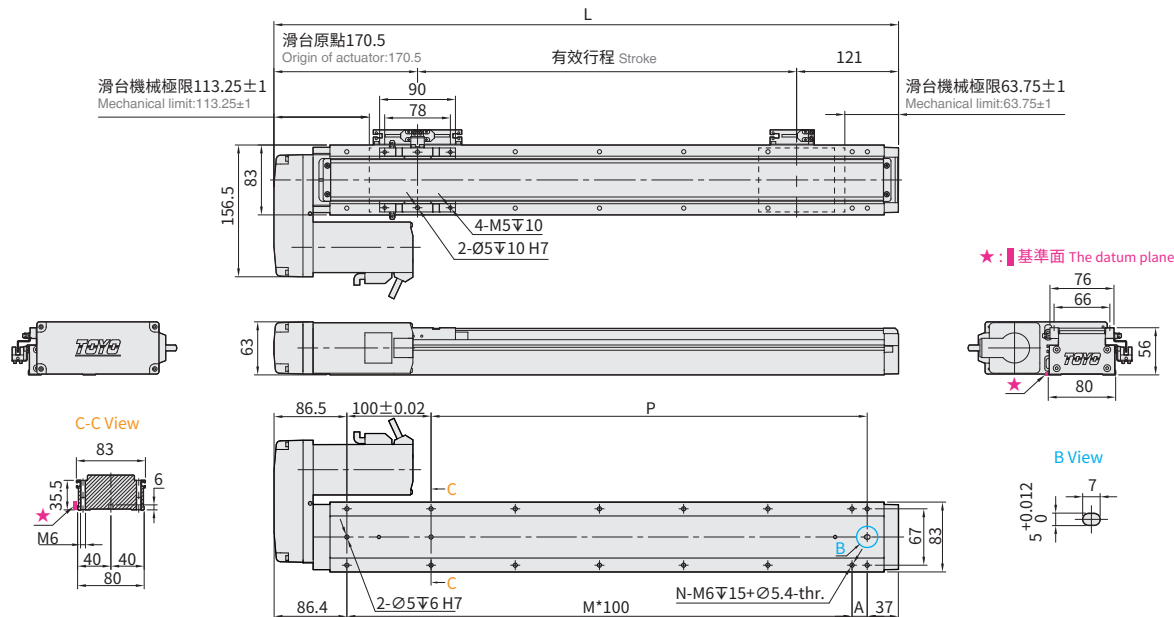

BR 馬達右折 Motor Right Side

單位 Unit : mm

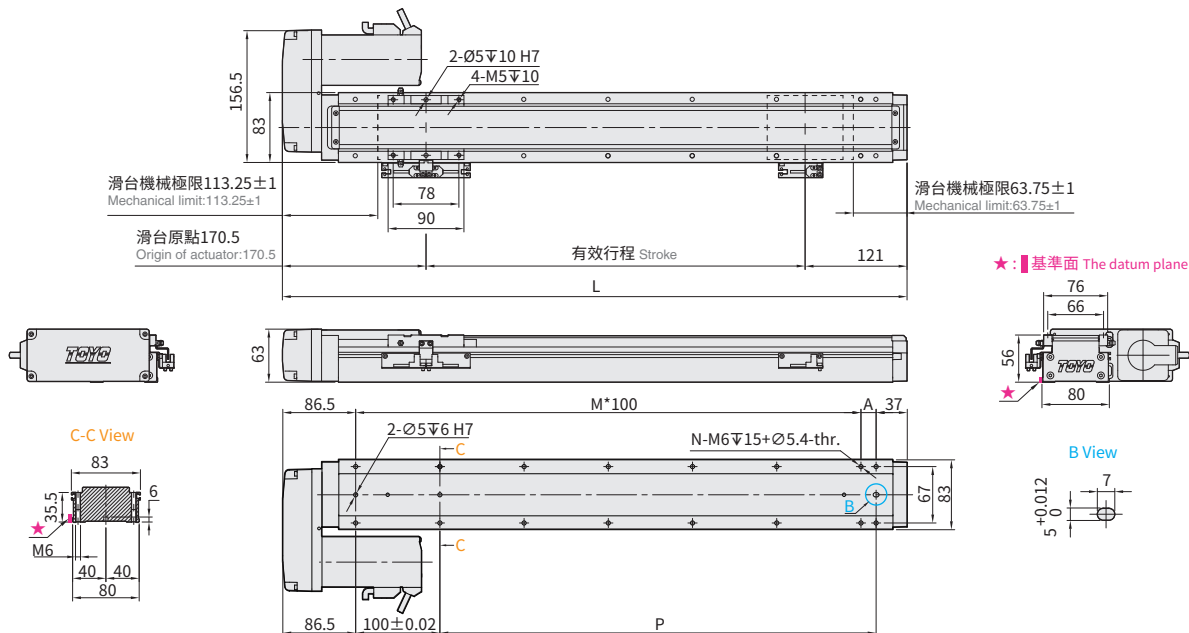

有效行程 Stroke	50 ⁻¹	100	150	200	250	300	350	400	450	500	550	600	650	700	750	800	850	900	950	1000	1050	1100	1150	1200	1250									
極限行程 Limit Stroke (±1)	74.5	124.5	174.5	224.5	274.5	324.5	374.5	424.5	474.5	524.5	574.5	624.5	674.5	724.5	774.5	824.5	874.5	924.5	974.5	1024.5	1074.5	1124.5	1174.5	1224.5	1274.5									
L	341.5	391.5	441.5	491.5	541.5	591.5	641.5	691.5	741.5	791.5	841.5	891.5	941.5	991.5	1041.5	1091.5	1141.5	1191.5	1241.5	1291.5	1341.5	1391.5	1441.5	1491.5	1541.5									
A	18	68	18	68	18	68	18	68	18	68	18	68	18	68	18	68	18	68	18	68	18	68	18	68	18									
M	2	2	3	3	4	4	5	5	6	6	7	7	8	8	9	9	10	10	11	11	12	12	13	13	14									
N	8	8	10	10	12	12	14	14	16	16	18	18	20	20	22	22	24	24	26	26	28	28	30	30	32									
P	118	168	218	268	318	368	418	468	518	568	618	668	718	768	818	868	918	968	1018	1068	1118	1168	1218	1268	1318									
KG	2.74	3.04	3.33	3.63	3.93	4.22	4.52	4.81	5.11	5.41	5.7	6	6.3	6.59	6.89	7.19	7.48	7.78	8.07	8.37	8.67	8.96	9.26	9.56	9.85									
線速度 Linear Speed mm/s	導程 Lead 6	360										350										310	270	240	210	190	170	160	140	130	120	110	100	90
	導程 Lead 12	720										700										620	540	480	420	380	340	320	280	260	240	220	200	180
	導程 Lead 24	1440										1400										1240	1080	960	840	760	680	640	560	520	480	440	400	360

※1行程 50 時，因本體上鎖式固定孔會被滑座遮住，僅能使用 4 支螺絲固定，建議客戶本體使用下鎖式固定孔鎖附。When the stroke is 50mm, if fixing the body from the top to the bottom, the fixing hole will be blocked by slider and only can be uses 4 screws to fix; as a result, suggest that fixing actuator body from the bottom to the top.

應用例
Application

一般 / 螺桿仕様
GLTH

一般 / 皮帶仕様
ETB / M

無塵 / 螺桿仕様
GCH / ECH

無塵 / 皮帶仕様
ECB

直交連結
XYGT / XTH / XYTB

參考資料
Reference

GLTH Series

GLTH3

GLTH5

GLTH8

GLTH12

GLTH5D

GLTH8D

GLMH5

GLMH8

GLTH5M

GLTH8M

GLMH8 單軸 /1-axis

▶ 軌道內嵌
Integrated Linear Bearing

▶ 螺桿驅動
Ball Screw Drive

精度
±0.005
mm



最大行程
Maximum Stroke 1250mm

最高速度
Maximum Speed 1440mm/s

馬達容量
Motor Output 400W

最大可搬重量
Max Payload 105kg

型號表示方式 Ordering Method

GLMH8 - L6 - 100 - BC - M40B - C4N5 - 參照右頁
Refer to the right page. - 0001

本體型號
Model

行程^{*1}
Stroke

50-1250mm
50間隔 50 mm Pitch

選配
Options

特注式樣
Customization Order No.

馬達位置
Motor Position

BC	馬達外露 Motor Exposed
BM	馬達下折 Motor Bottom Side
BL	馬達左折 Motor Left Side
BR	馬達右折 Motor Right Side

馬達廠牌、功率
Motor Brand · Power Output

M	三菱 Mitsubishi	05	-	B ^{*2}
P	松下 Panasonic	10	-	
Y	安川 Yaskawa	20	-	
T	台達 Delta	40	400W	

原點感應器
Home Sensor

外掛型 Out Side	
C	馬達側 Motor Side
D	反馬達側 Opposite Motor Side
	無 SENSOR No Sensor
E	無 SENSOR No Sensor

端點極限感應器
Limit Sensor

外掛型 Out Side	
3	1只 1 Pc
4	2只 2 Pcs
6	3只 3 Pcs
7	4只 4 Pcs
8	5只 5 Pcs
9	6只 6 Pcs
	無 SENSOR No Sensor
5	無 SENSOR No Sensor

輸出方式&線長
Output type & Cable length

N5	NPN+5米線 NPN+5M Cable
P2	PNP+2米線 PNP+2M Cable
P5	PNP+5米線 PNP+5M Cable
-	NPN+2米線 NPN+2M Cable

螺桿導程
Ball Screw Lead

6	6mm
12	12mm
24	24mm

*1 選擇行程50時，光電使用有以下限制：When the stroke is 50mm, the sensor installation has the following restrictions:

馬達方向 BC/BM：1.原點與極限需放置於不同側。2.滑座左右兩側皆需安裝感應片。Motor Direction BC/BM 1.Home sensor and limit sensor has to be installed on the different side of body. 2.Both sides of slider need to install the sensor trigger device.
馬達方向 BL/BR：1.原點+極限感應器最數量最多2只(僅能選用C3/D3/E3/E4/E5)。Motor Direction BL/BR 1.Home + limit sensors is 2 maximum (only C3/D3/E3/E4/E5 can be selected)

*2 馬達若無煞車則不表示。If Motor No Brake, No Description.

基本仕様 Specification

性能	位置重複精度 Repeatability	mm	±0.005			
	螺桿導程 Lead	mm	6	12	24	
	最高轉速 Maximum Rotating speed	rpm	3600	3600	3600	
	最高速度 Maximum linear speed ※1	mm/s	360	720	1440	
	最大可搬重量 Maximum Payload	水平使用 Horizontal	kg	105	85	40
		垂直使用 Vertical	kg	30	20	10
	定格推力 Rated Thrust	N	1156	578	289	
	標準行程 Stroke (increments)	mm	50-1250mm / 50 間隔 (50 increments)			
	最大加速度 Maximum acceleration	G	0.37	0.73	1.47	
	滾珠螺桿 Ball screw	基本動額定負荷 Basic dynamic load rating Ca	N	7733	5855	3007
基本靜額定負荷 Basic static load rating Coa		N	14200	10401	5414	
直線滑軌 Linear Guide	動態水平負載 Dynamic horizontal (100km)	N	18601			
	靜態水平負載 Static Horizontal	N	34189			
固定側軸承 Fixed bearing	基本動額定負荷 Basic dynamic load rating Cr	N	8447			
	靜態容許負荷 Static load rating Cor	N	5060			
部品	AC 伺服馬達容量 AC Servo Motor Output	W	400			
	滾珠螺桿外徑 Ball Screw Ø	mm	C7Ø14			
	連軸器 Coupling	mm	10X14			
	原點感應器 Home Sensor	外掛 Outside	T64N2 (NPN+2 米線) (NPN+2M Cable)			

※1 長行程時，會產生螺桿偏擺，需將速度調降 (線速度請參閱尺寸圖下方表格)

During in a long stroke, it causes ballscrew deflection, the speed must reduce. (Please refer to the linear velocity from the data sheet below the dimension graph.)

容許負載力距表 Allowable Overhang

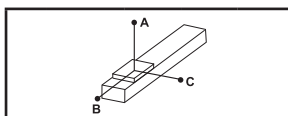

(單位 Unit : mm)

水平安裝 Horizontal Installation	A	B	C
導程 6 Lead	30kg	1900	261
	50kg	1080	88
	105kg	434	29
導程 12 Lead	25kg	780	175
	35kg	530	117
	85kg	175	33
導程 24 Lead	4kg	1400	820
	12kg	440	257
	40kg	109	60

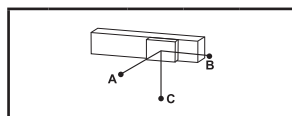

(單位 Unit : mm)

壁掛安裝 Wall Installation	A	B	C
導程 6 Lead	30kg	261	165
	50kg	140	88
	105kg	47	29
導程 12 Lead	25kg	240	175
	35kg	160	117
	85kg	46	33
導程 24 Lead	4kg	750	820
	12kg	235	257
	40kg	55	60

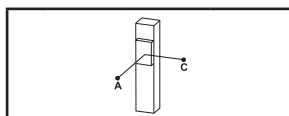

(單位 Unit : mm)

垂直安裝 Vertical Installation	A	C
導程 6 Lead	16kg	335
	30kg	180
	-	-
導程 12 Lead	12kg	400
	20kg	240
	-	-
導程 24 Lead	6kg	460
	10kg	275
	-	-

靜額定扭矩 Static Loading Moment

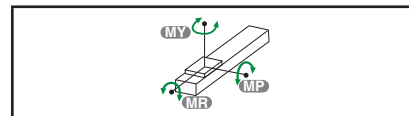

(單位 Unit : N.m)

MY	137
MP	137
MR	227

* 力矩表所表示的數據，代表荷重的重心位置於單一方向容許懸出的長度。
The data represented by the moment table is the center of gravity of the load. The length of the overhang is allowed in a single direction.
* 符合型錄規範的正常使用下，保證壽命為 10000 公里。
Operation life is 10,000km when the product is using under the specified conditions.
* 倒吊使用無法套用標準規範，如有需求請洽詢我司業務。
Data information is not for ceiling-mount inverse use. Contact us for the details if you want to apply ceiling-mount inverse usage.
* 壽命及力矩是以馬達加減速設定 0.2 秒計算。
The life and torque are calculated by setting the motor acceleration and deceleration for 0.2 seconds.

選配 Options

MM

指定馬達出線方向 Selectable Cable Leading Direction		
代號 Code	說明 Instructions	需參照 Refer to
MW	朝上 Upper side	P.111 ~ P.112
MM	朝下 Bottom side	
ML	朝左 Left side	
MR	朝右 Right side	

CMK

馬達傳動配件追加鍵槽 Additional keyway for motor drive parts				
代號 Code	說明 Instructions			需參照 Refer to
	追加鍵槽 Keyway Groove	馬達位置 Motor Position	出貨型式 Shipment Type	
CMK	單邊 (限定馬達側) Single (Limited to the motor side)	BC	鍵槽式聯軸器 Keyway Coupling	P.113 ~ P.115
		BL/BR/BM	鍵槽式皮帶輪 Keyway Belt Pulley	
SKY	雙邊 Double	BC	鍵槽式聯軸器 Keyway Coupling	
		BL/BR/BM	鍵槽式皮帶輪 Keyway Belt Pulley	
SKN	雙邊 Double	BC	無聯軸器 (請自行購買安裝) Without Coupling (Please purchase and install by yourself)	
		BL/BR/BM	無馬達端皮帶輪 (請自行購買安裝) Without Belt Pulley (Please purchase and install by yourself)	

GLTH Series

- GLTH3
- GLTH5
- GLTH8
- GLTH12
- GLTH5D
- GLTH8D
- GLMH5
- GLMH8**
- GLTH5M
- GLTH8M

GLMH8 單軸 /1-axis

▶ 軌道內嵌
Integrated Linear Bearing

▶ 螺桿驅動
Ball Screw Drive



Download at www.toyorobot.com

BC 馬達外露 Motor Exposed

單位 Unit : mm

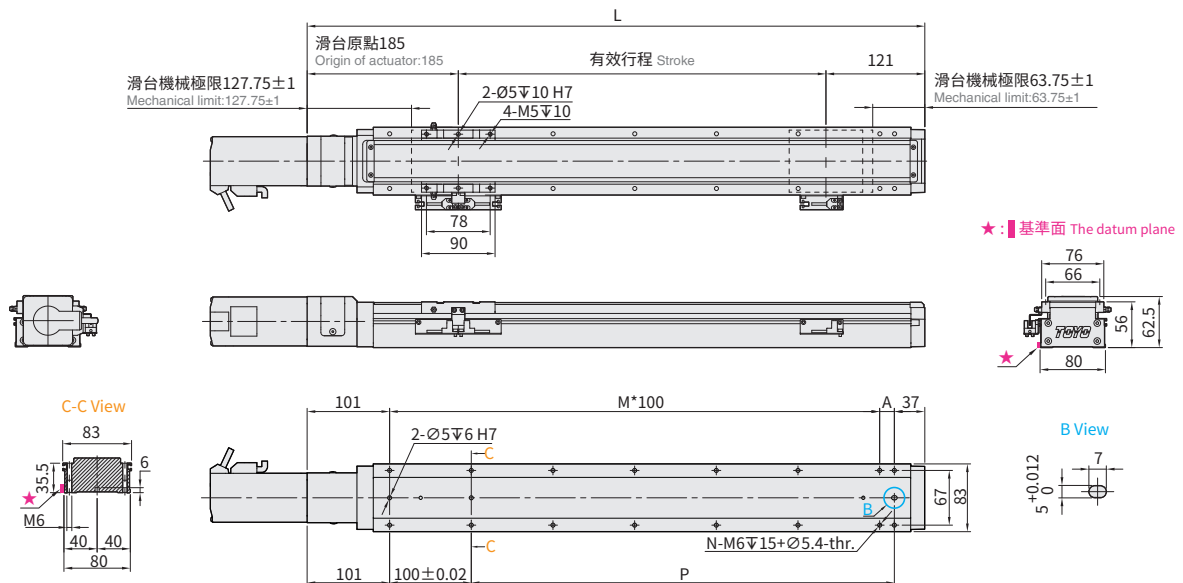

BM 馬達下折 Motor Bottom Side

單位 Unit : mm

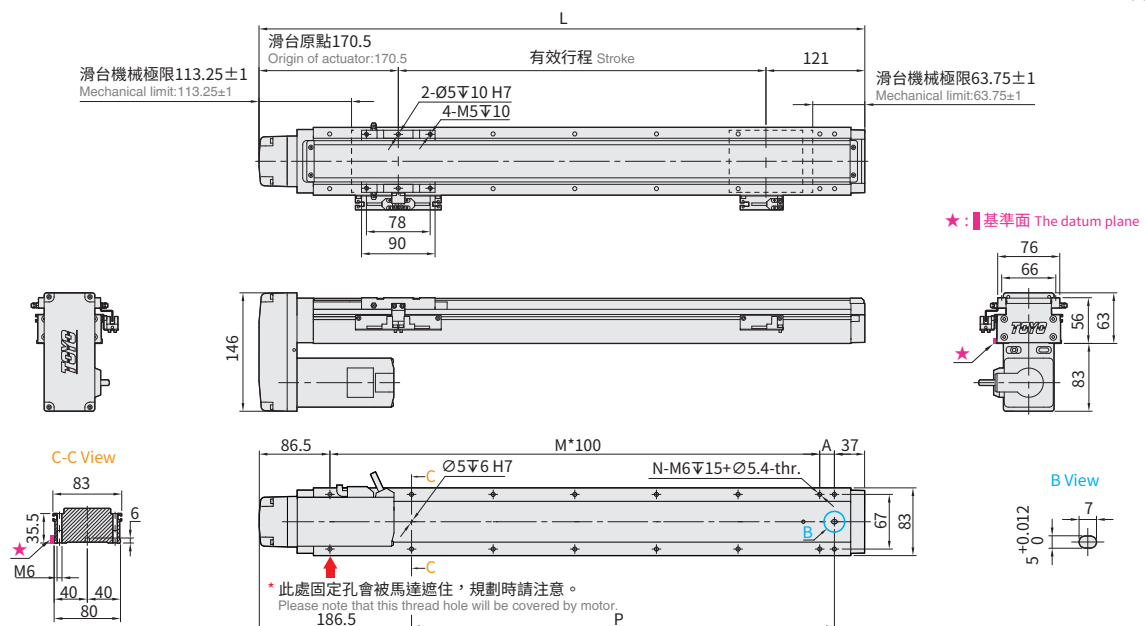

有效行程 Stroke	50 ⁻¹	100	150	200	250	300	350	400	450	500	550	600	650	700	750	800	850	900	950	1000	1050	1100	1150	1200	1250	
極限行程 Limit Stroke (±1)	74.5	124.5	174.5	224.5	274.5	324.5	374.5	424.5	474.5	524.5	574.5	624.5	674.5	724.5	774.5	824.5	874.5	924.5	974.5	1024.5	1074.5	1124.5	1174.5	1224.5	1274.5	
L	BC	356	406	456	506	556	606	656	706	756	806	856	906	956	1006	1056	1106	1156	1206	1256	1306	1356	1406	1456	1506	1556
	BM	341.5	391.5	441.5	491.5	541.5	591.5	641.5	691.5	741.5	791.5	841.5	891.5	941.5	991.5	1041.5	1091.5	1141.5	1191.5	1241.5	1291.5	1341.5	1391.5	1441.5	1491.5	1541.5
A	18	68	18	68	18	68	18	68	18	68	18	68	18	68	18	68	18	68	18	68	18	68	18	68	18	68
M	2	2	3	3	4	4	5	5	6	6	7	7	8	8	9	9	10	10	11	11	12	12	13	13	14	
N	8	8	10	10	12	12	14	14	16	16	18	18	20	20	22	22	24	24	26	26	28	28	30	30	32	
P	118	168	218	268	318	368	418	468	518	568	618	668	718	768	818	868	918	968	1018	1068	1118	1168	1218	1268	1318	
KG	BC	2.37	2.67	2.96	3.26	3.55	3.85	4.15	4.44	4.74	5.02	5.33	5.63	5.93	6.22	6.52	6.81	7.11	7.41	7.7	8	8.3	8.59	8.89	9.19	9.48
	BM	2.74	3.04	3.33	3.63	3.93	4.22	4.52	4.81	5.11	5.41	5.7	6	6.3	6.59	6.89	7.19	7.48	7.78	8.07	8.37	8.67	8.96	9.26	9.56	9.85
線速度 Linear Speed mm/s	導程 Lead 6	360																								
	導程 Lead 12	700												620												
	導程 Lead 24	1400												1400												

* 1 行程 50 時，因本體上鎖式固定孔會被滑座遮住，僅能使用 4 支螺絲固定，建議客戶本體使用下鎖式固定孔鎖附。When the stroke is 50mm, if fixing the body from the top to the bottom, the fixing hole will be blocked by slider and only can be uses 4 screws to fix; as a result, suggest that fixing actuator body from the bottom to the top.



Download at www.toyorobot.com

BL 馬達左折 Motor Left Side

單位 Unit : mm

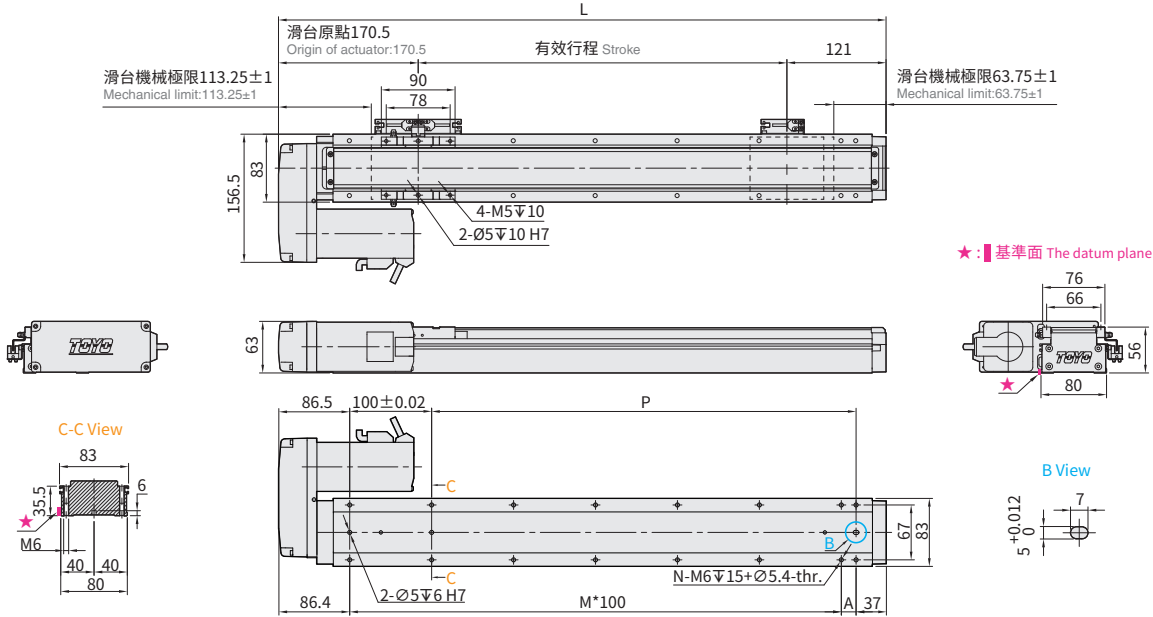

BR 馬達右折 Motor Right Side

單位 Unit : mm

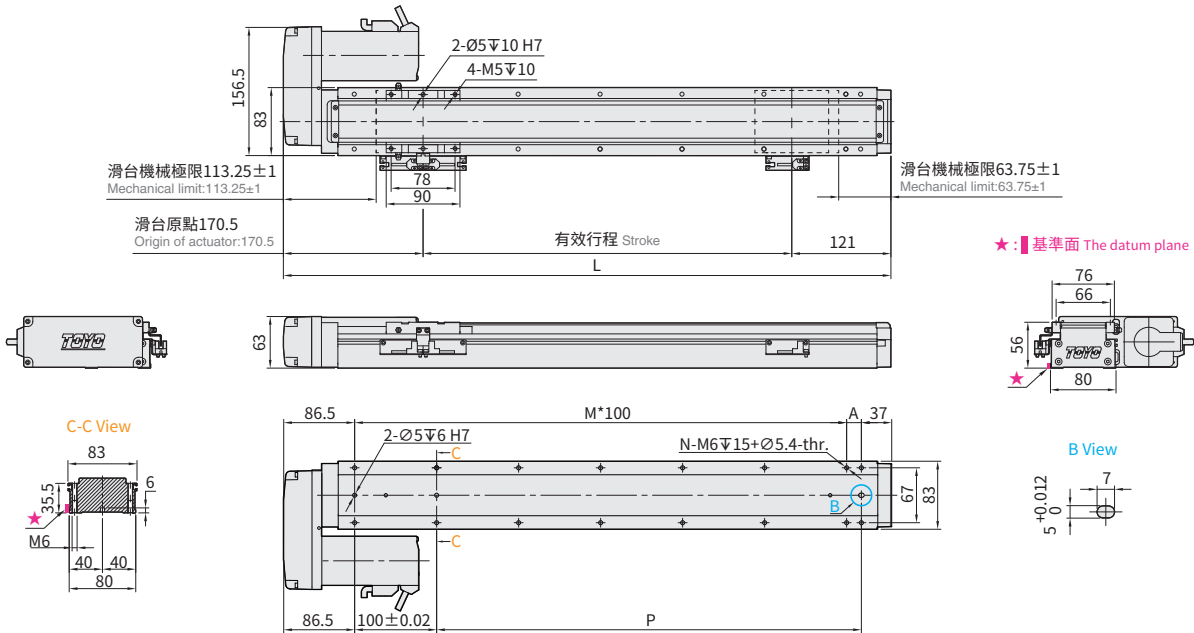

有效行程 Stroke	50 ^{±1}	100	150	200	250	300	350	400	450	500	550	600	650	700	750	800	850	900	950	1000	1050	1100	1150	1200	1250																																																																																																																														
極限行程 Limit Stroke (±1)	74.5	124.5	174.5	224.5	274.5	324.5	374.5	424.5	474.5	524.5	574.5	624.5	674.5	724.5	774.5	824.5	874.5	924.5	974.5	1024.5	1074.5	1124.5	1174.5	1224.5	1274.5																																																																																																																														
L	341.5	391.5	441.5	491.5	541.5	591.5	641.5	691.5	741.5	791.5	841.5	891.5	941.5	991.5	1041.5	1091.5	1141.5	1191.5	1241.5	1291.5	1341.5	1391.5	1441.5	1491.5	1541.5																																																																																																																														
A	18	68	18	68	18	68	18	68	18	68	18	68	18	68	18	68	18	68	18	68	18	68	18	68	18																																																																																																																														
M	2	2	3	3	4	4	5	5	6	6	7	7	8	8	9	9	10	10	11	11	12	12	13	13	14																																																																																																																														
N	8	8	10	10	12	12	14	14	16	16	18	18	20	20	22	22	24	24	26	26	28	28	30	30	32																																																																																																																														
P	118	168	218	268	318	368	418	468	518	568	618	668	718	768	818	868	918	968	1018	1068	1118	1168	1218	1268	1318																																																																																																																														
KG	2.74	3.04	3.33	3.63	3.93	4.22	4.52	4.81	5.11	5.41	5.7	6	6.3	6.59	6.89	7.19	7.48	7.78	8.07	8.37	8.67	8.96	9.26	9.56	9.85																																																																																																																														
線速度 Linear Speed mm/s	導程 Lead 6	360										350										310										270										240										210										190										170										160										140										130										120										110										100										90									
	導程 Lead 12	720										700										620										540										480										420										380										340										320										280										260										240										220										200										180									
	導程 Lead 24	1440										1400										1240										1080										960										840										760										680										640										560										520										480										440										400										360									

※1行程 50 時，因本體上鎖式固定孔會被滑座遮住，僅能使用 4 支螺絲固定，建議客戶本體使用下鎖式固定孔鎖附。When the stroke is 50mm, if fixing the body from the top to the bottom, the fixing hole will be blocked by slider and only can be uses 4 screws to fix; as a result, suggest that fixing actuator body from the bottom to the top.

應用例
Application

一般 / 螺桿仕様
GLTH

一般 / 皮帶仕様
ETB / M

無塵 / 螺桿仕様
GCH / ECH

無塵 / 皮帶仕様
ECB

直交連結
XYGT / XTH / XYTB

參考資料
Reference

GLTH Series

GLTH3

GLTH5

GLTH8

GLTH12

GLTH5D

GLTH8D

GLMH5

GLMH8

GLTH5M

GLTH5M

GLTH5M 單軸 /1-axis

▶ 軌道內嵌
Integrated Linear Bearing

▶ 螺桿驅動
Ball Screw Drive

精度
±0.005 mm



此圖僅供參考，出貨規格詳見尺寸圖面
The picture is just for the reference. Please check the the actual dimensions on the drawing.

最大行程 Maximum Stroke	2000mm	最高速度 Maximum Speed	1200mm/s	馬達容量 Motor Output	100W	最大可搬重量 Max Payload	30kg
------------------------	--------	-----------------------	----------	----------------------	------	-----------------------	------

型號表示方式 Ordering Method

GLTH5M - L2 - 800 - BC - M10B - C4N5 - 參照右頁
Refer to the right page. - 0001

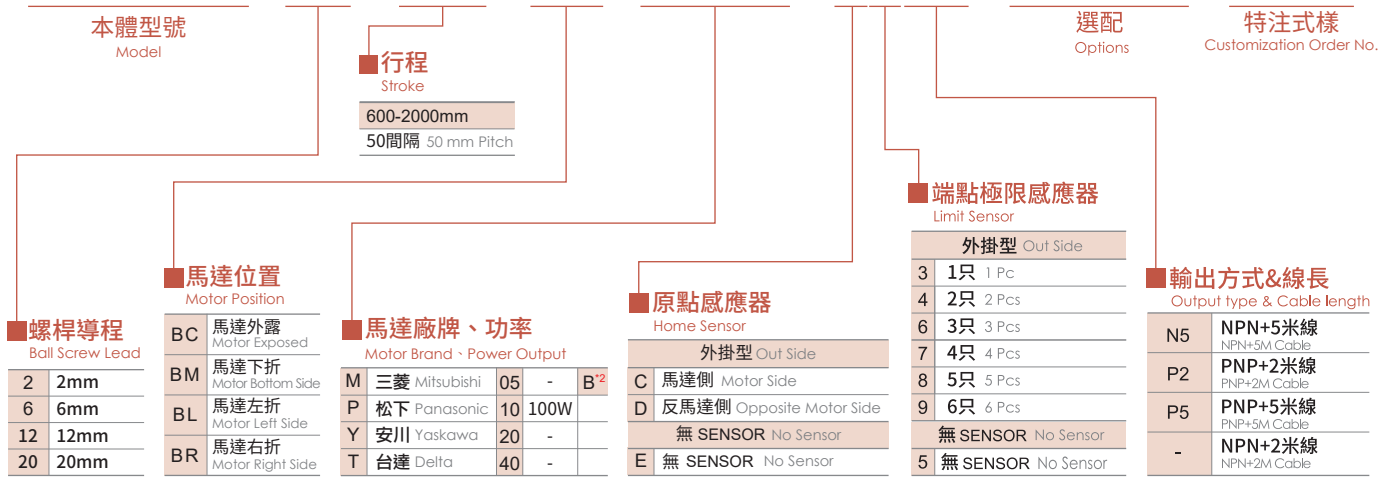

*2 馬達若無煞車則不表示。 If Motor No Brake, No Description.

基本仕様 Specification

性能	位置重複精度 Repeatability	mm	±0.005				
	螺桿導程 Lead	mm	2	6	12	20	
	最高轉速 Maximum Rotating speed	rpm	3600	3600	3600	3600	
	最高速度 Maximum linear speed ^{※1}	mm/s	120	360	720	1200	
	最大可搬重量 ^{※2} Maximum Payload	水平使用 Horizontal	kg	30	25	22	10
		垂直使用 Vertical	kg	10	6	4	3
	定格推力 Rated Thrust	N	854	284	142	85	
	標準行程 Stroke (increments)	mm	650-2000mm /50 間隔 (50 increments)				
	最大加速度 Maximum acceleration	G	0.12	0.37	0.73	1.22	
	滾珠螺桿 Ball screw	基本動額定負荷 Basic dynamic load rating Ca	N	2270	2243	1436	1384
基本靜額定負荷 Basic static load rating Coa		N	4836	3959	2441	2535	
直線滑軌 Linear Guide	動態水平負載 Dynamic horizontal (100km)	N	6563				
	靜態水平負載 Static Horizontal	N	13587				
固定側軸承 Fixed bearing	基本動額定負荷 Basic dynamic load rating Cr	N	5361				
	靜態容許負荷 Static load rating Cor	N	2880				
部品	AC 伺服馬達容量 AC Servo Motor Output	W	100				
	滾珠螺桿外徑 Ball Screw Ø	mm	C7Ø10				
	連軸器 Coupling	mm	7X8				
	原點感應器 Home Sensor	外掛 Outside	T64N2 (NPN+2 米線) (NPN+2M Cable)				

※1 長行程時，會產生螺桿偏擺，需將速度調降 (線速度請參閱尺寸圖下方表格)

During in a long stroke, it causes ballscrew deflection, the speed must reduce. (Please refer to the linear velocity from the data sheet below the dimension graph.)

※2 由於各廠牌的馬達性能不同，需速度搭配回升電阻以達到此荷重條件。

Since the motor performance of each brand is different, a regenerative resistor needs to be appropriately matched to achieve this load condition.

容許負載力距表 Allowable Overhang

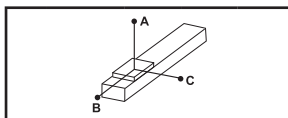

(單位 Unit : mm)

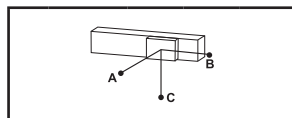

(單位 Unit : mm)

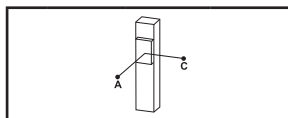

(單位 Unit : mm)

水平安裝 Horizontal Installation		A	B	C
導程 2 Lead	10kg	2500	157	250
	20kg	1120	70	112
	30kg	650	41	65
導程 6 Lead	10kg	1400	122	184
	20kg	650	52	79
	25kg	490	38	57
導程 12 Lead	8kg	590	132	175
	10kg	460	103	135
	22kg	185	37	49
導程 20 Lead	3kg	656	300	303
	6kg	314	141	144
	10kg	177	78	79

壁掛安裝 Wall Installation		A	B	C
導程 2 Lead	10kg	250	157	2500
	20kg	112	70	1120
	30kg	65	41	650
導程 6 Lead	10kg	184	122	1400
	20kg	79	52	650
	25kg	57	38	490
導程 12 Lead	8kg	175	132	590
	10kg	135	103	460
	22kg	49	37	185
導程 20 Lead	3kg	303	300	656
	6kg	144	141	314
	10kg	79	78	177

垂直安裝 Vertical Installation		A	C
導程 2 Lead	5kg	346	346
	10kg	173	173
	-	-	-
導程 6 Lead	3kg	463	463
	6kg	231	231
	-	-	-
導程 12 Lead	2.5kg	465	465
	4kg	292	292
	-	-	-
導程 20 Lead	1.5kg	555	555
	3g	278	278
	-	-	-

靜額定扭矩 Static Loading Moment

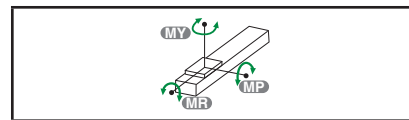

(單位 Unit : N.m)

MY	73
MP	73
MR	115

* 力矩表所表示的數據，代表荷重的重心位置於單方向容許懸出的長度。The data represented by the moment table is the center of gravity of the load. The length of the overhang is allowed in a single direction.

* 符合型錄規範的正常使用下，保證壽命為 10000 公里。

Operation life is 10,000km when the product is using under the specified conditions.

* 倒置使用無法套用標準規範，如有需求請洽詢我司業務。

Data information is not for ceiling-mount inverse use. Contact us for the details if you want to apply ceiling-mount inverse usage.

* 壽命及力矩是以馬達加減速設定 0.2 秒計算。

The life and torque are calculated by setting the motor acceleration and deceleration for 0.2 seconds.

選配 Options

MM

指定馬達出線方向 Selectable Cable Leading Direction		
代號 Code	說明 Instructions	需參照 Refer to
MW	朝上 Upper side	P.111 ~ P.112
MM	朝下 Bottom side	
ML	朝左 Left side	
MR	朝右 Right side	

CMK

馬達傳動配件追加鍵槽 Additional keyway for motor drive parts				
代號 Code	說明 Instructions			需參照 Refer to
	追加鍵槽 Keyway Groove	馬達位置 Motor Position	出貨型式 Shipment Type	
CMK	單邊 (限定馬達側) Single (Limited to the motor side)	BC	鍵槽式聯軸器 Keyway Coupling	P.113 ~ P.115
		BL/BR/BM	鍵槽式皮帶輪 Keyway Belt Pulley	
SKY	雙邊 Double	BC	鍵槽式聯軸器 Keyway Coupling	
		BL/BR/BM	鍵槽式皮帶輪 Keyway Belt Pulley	
SKN	雙邊 Double	BC	無聯軸器 (請自行購買安裝) Without Coupling (Please purchase and install by yourself)	
		BL/BR/BM	無馬達端皮帶輪 (請自行購買安裝) Without Belt Pulley (Please purchase and install by yourself)	

GLTH Series

- GLTH3
- GLTH5
- GLTH8
- GLTH12
- GLTH5D
- GLTH8D
- GLMH5
- GLMH8
- GLTH5M**
- GLTH8M

GLTH5M 單軸 /1-axis

▶ 軌道內嵌
Integrated Linear Bearing

▶ 螺桿驅動
Ball Screw Drive



• Download at www.toyorobot.com •

BC 馬達外露 Motor Exposed

單位 Unit : mm

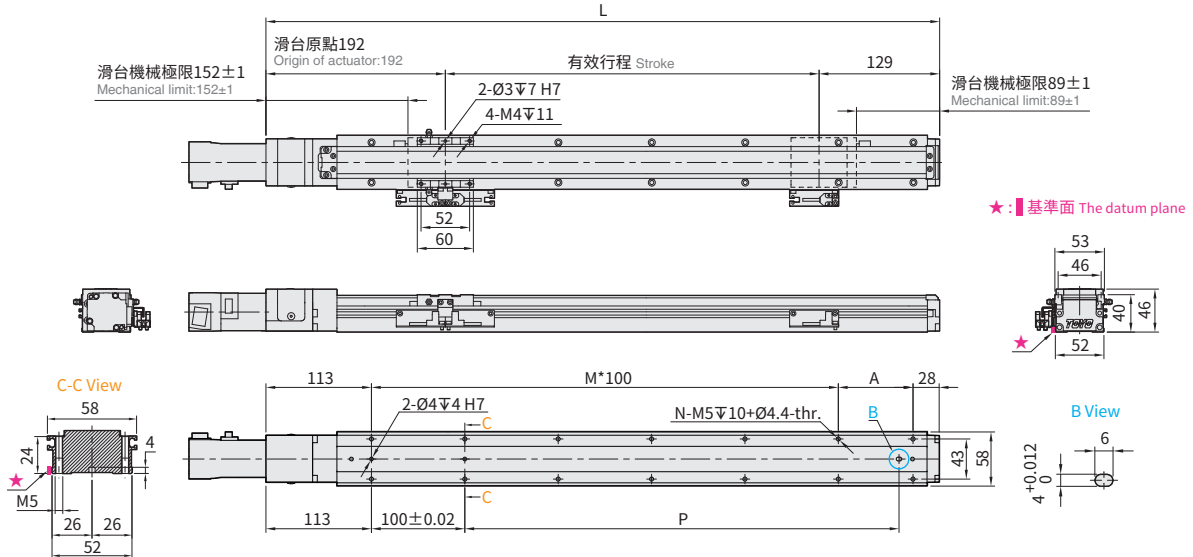

BM 馬達下折 Motor Bottom Side

單位 Unit : mm

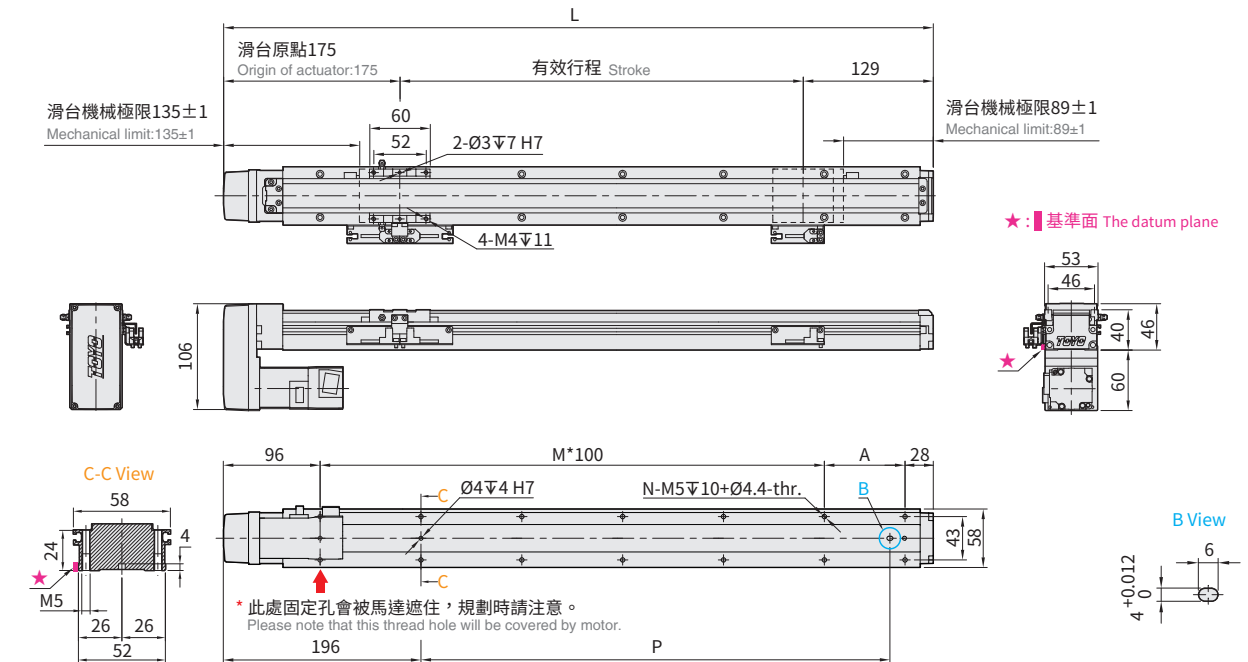

有效行程 Stroke	650	700	750	800	850	900	950	1000	1050	1100	1150	1200	1250	1300	1350	1400	1450	1500	1550	1600	1650	1700	1750	1800	1850	1900	1950	2000		
極限行程 Limit Stroke (±1)	670	720	770	820	870	920	970	1020	1070	1120	1170	1220	1270	1320	1370	1420	1470	1520	1570	1620	1670	1720	1770	1820	1870	1920	1970	2020		
L	BC	971	1021	1071	1121	1171	1221	1271	1321	1371	1421	1471	1521	1571	1621	1671	1721	1771	1821	1871	1921	1971	2021	2071	2121	2171	2221	2271	2321	
	BM	954	1004	1054	1104	1154	1204	1254	1304	1354	1404	1454	1504	1554	1604	1654	1704	1754	1804	1854	1904	1954	2004	2054	2104	2154	2204	2254	2304	
A	30	80	30	80	30	80	30	80	30	80	30	80	30	80	30	80	30	80	30	80	30	80	30	80	30	80	30	80	30	80
M	8	8	9	9	10	10	11	11	12	12	13	13	14	14	15	15	16	16	17	17	18	18	19	19	20	20	21	21	21	
N	20	20	22	22	24	24	26	26	28	28	30	30	32	32	34	34	36	36	38	38	40	40	42	42	44	44	46	46	46	
P	715	765	815	865	915	965	1015	1065	1115	1165	1215	1265	1315	1365	1415	1465	1515	1565	1615	1665	1715	1765	1815	1865	1915	1965	2015	2065		
KG	BC	3.06	3.19	3.32	3.45	3.58	3.7	3.83	3.96	4.08	4.21	4.34	4.46	4.59	4.71	4.84	4.97	5.09	5.22	5.35	5.47	5.6	5.73	5.85	5.98	6.1	6.23	6.36	6.48	
	BM	3.14	3.27	3.4	3.53	3.66	3.78	3.91	4.04	4.16	4.29	4.42	4.54	4.67	4.79	4.92	5.05	5.17	5.3	5.43	5.55	5.68	5.81	5.93	6.06	6.18	6.31	6.44	6.56	
線速度 Linear Speed mm/s	導程 Lead 2	120																												
	導程 Lead 6	360																												
	導程 Lead 12	720																												
	導程 Lead 20	1200																												



Download at www.toyorobot.com

BL 馬達左折 Motor Left Side

單位 Unit : mm

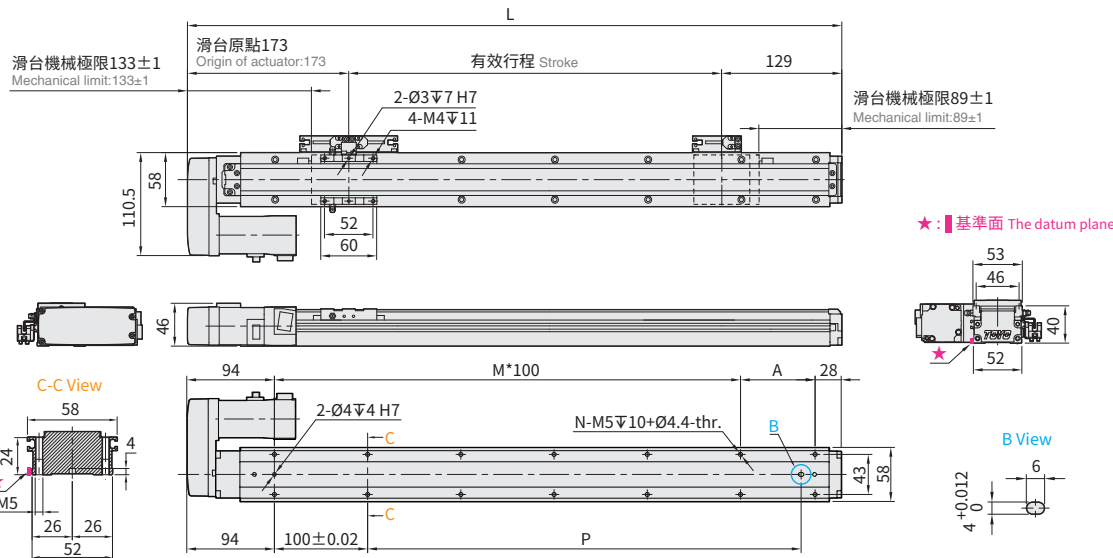

BR 馬達右折 Motor Right Side

單位 Unit : mm

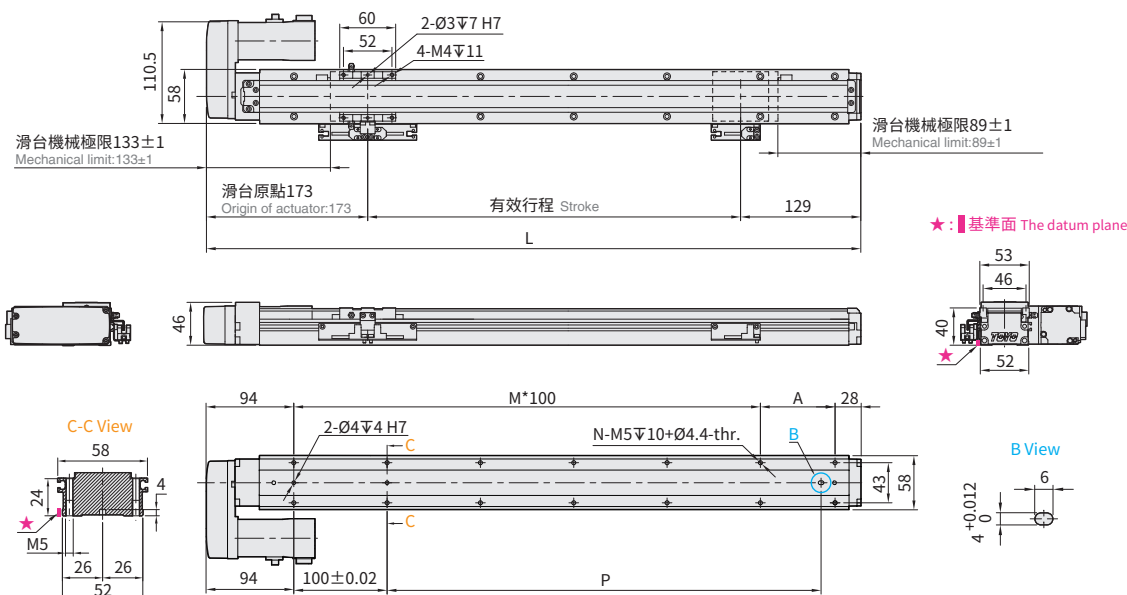

有效行程 Stroke	650	700	750	800	850	900	950	1000	1050	1100	1150	1200	1250	1300	1350	1400	1450	1500	1550	1600	1650	1700	1750	1800	1850	1900	1950	2000	
極限行程 Limit Stroke (±1)	670	720	770	820	870	920	970	1020	1070	1120	1170	1220	1270	1320	1370	1420	1470	1520	1570	1620	1670	1720	1770	1820	1870	1920	1970	2020	
L	952	1002	1052	1102	1152	1202	1252	1302	1352	1402	1452	1502	1552	1602	1652	1702	1752	1802	1852	1902	1952	2002	2052	2102	2152	2202	2252	2302	
A	30	30	30	30	30	30	30	30	30	30	30	30	30	30	30	30	30	30	30	30	30	30	30	30	30	30	30	30	30
M	8	8	9	9	10	10	11	11	12	12	13	13	14	14	15	15	16	16	17	17	18	18	19	19	20	20	21	21	
N	20	20	22	22	24	24	26	26	28	28	30	30	32	32	34	34	36	36	38	38	40	40	42	42	44	44	46	46	
P	715	765	815	865	915	965	1015	1065	1115	1165	1215	1265	1315	1365	1415	1465	1515	1565	1615	1665	1715	1765	1815	1865	1915	1965	2015	2065	
KG	3.14	3.27	3.4	3.53	3.66	3.78	3.91	4.04	4.16	4.29	4.42	4.54	4.67	4.79	4.92	5.05	5.17	5.3	5.43	5.55	5.68	5.81	5.93	6.06	6.18	6.31	6.44	6.56	
線速度 Linear Speed mm/s	導程 Lead 2	120																											
	導程 Lead 6	360																											
	導程 Lead 12	720																											
	導程 Lead 20	1200																											

- 應用例 Application
- 一般 / 螺桿仕様 GLTH
- 一般 / 皮帶仕様 ETB / M
- 無塵 / 螺桿仕様 GCH / ECH
- 無塵 / 皮帶仕様 ECB
- 直交連結 XYGT / XTH / XYTB
- 參考資料 Reference

- GLTH Series
- GLTH3
 - GLTH5
 - GLTH8
 - GLTH12
 - GLTH5D
 - GLTH8D
 - GLMH5
 - GLMH8
 - GLTH5M
 - GLTH8M

GLTH8M 單軸 /1-axis

▶ 軌道內嵌
Integrated Linear Bearing

▶ 螺桿驅動
Ball Screw Drive

精度
±0.005 mm



此圖僅供參考，出貨規格詳見尺寸圖面
The picture is just for the reference. Please check the the actual dimensions on the drawing.

最大行程 Maximum Stroke	2500mm	最高速度 Maximum Speed	1440mm/s	馬達容量 Motor Output	200W	最大可搬重量 Max Payload	80kg
------------------------	--------	-----------------------	----------	----------------------	------	-----------------------	------

型號表示方式 Ordering Method

GLTH8M - L6 - 700 - BC - M20B - C4N5 - 參照右頁
Refer to the right page. - 0001

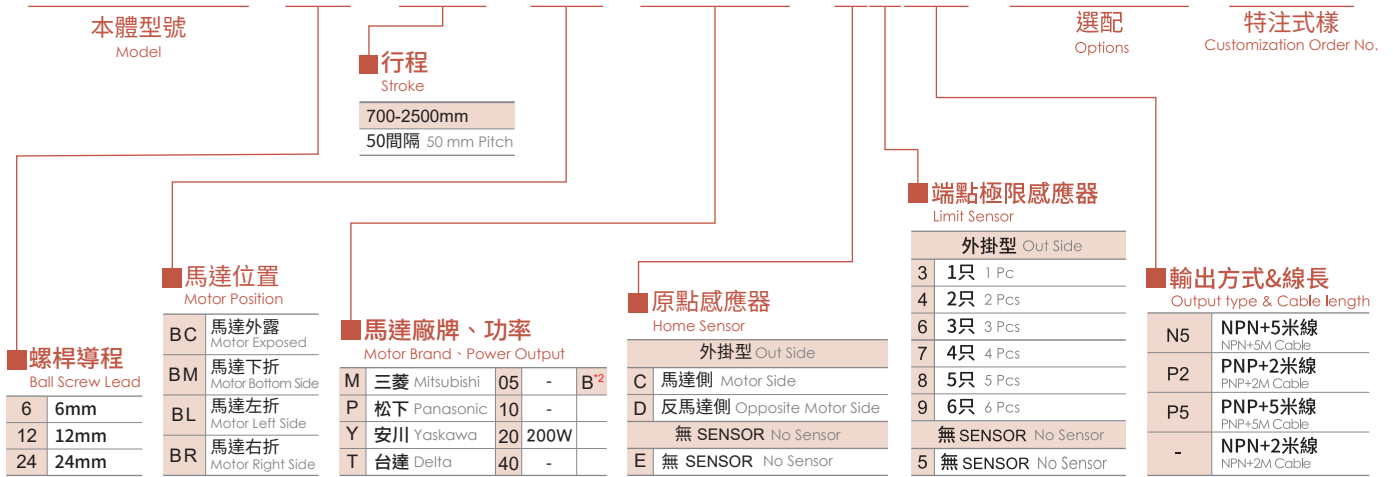

*2 馬達若無煞車則不表示。 If Motor No Brake, No Description.

基本仕様 Specification

性能	位置重複精度 Repeatability	mm	±0.005			
	螺桿導程 Lead	mm	6	12	24	
	最高轉速 Maximum Rotating speed	rpm	3600	3600	3600	
	最高速度 Maximum linear speed ^{※1}	mm/s	360	720	1440	
	最大可搬重量 ^{※2} Maximum Payload	水平使用 Horizontal	kg	80	60	40
		垂直使用 Vertical	kg	15	8	5
	定格推力 Rated Thrust	N	569	284	142	
	標準行程 Stroke (increments)	mm	700-2500mm / 50 間隔 (50 increments)			
	最大加速度 Maximum acceleration	G	0.37	0.73	1.47	
	滾珠螺桿 Ball screw	基本動額定負荷 Basic dynamic load rating Ca	N	7733	5855	3007
基本靜額定負荷 Basic static load rating Coa		N	14200	10401	5414	
直線滑軌 Linear Guide	動態水平負載 Dynamic horizontal (100km)	N	18601			
	靜態水平負載 Static Horizontal	N	34189			
固定側軸承 Fixed bearing	基本動額定負荷 Basic dynamic load rating Cr	N	8447			
	靜態容許負荷 Static load rating Cor	N	5060			
部品	AC 伺服馬達容量 AC Servo Motor Output	W	200			
	滾珠螺桿外徑 Ball Screw Ø	mm	C7Ø14			
	連軸器 Coupling	mm	10X14 / 11 ^{※3}			
	原點感應器 Home Sensor	外掛 Outside	T64N2 (NPN+2 米線) (NPN+2M Cable)			

※1 長行程時，會產生螺桿偏擺，需將速度調降 (線速度請參閱尺寸圖下方表格)

During in a long stroke, it causes ballscrew deflection, the speed must reduce. (Please refer to the linear velocity from the data sheet below the dimension graph.)

※2 由於各廠牌的馬達性能不同，需適度搭配回升電阻以達到此荷重條件。

Since the motor performance of each brand is different, a regenerative resistor needs to be appropriately matched to achieve this load condition.

※3 使用 Panasonic 200W 馬達時，馬達軸心為 Ø11；其他廠牌，馬達軸心為 Ø14。Motor (200W) Shaft Diameter: Panasonic: 11mm; Other: 14mm.

容許負載力距表 Allowable Overhang

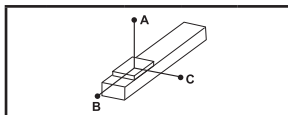

(單位 Unit: mm)

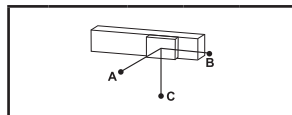

(單位 Unit: mm)

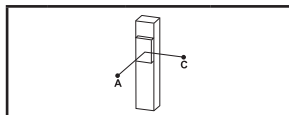

(單位 Unit: mm)

水平安裝 Horizontal Installation		A	B	C
導程 6 Lead	35kg	1600	139	220
	45kg	1210	102	160
	80kg	620	46	74
導程 12 Lead	10kg	2040	470	645
	30kg	638	141	193
	60kg	283	58	80
導程 24 Lead	20kg	253	145	133
	40kg	109	60	55
	-	-	-	-

壁掛安裝 Wall Installation		A	B	C
導程 6 Lead	35kg	220	139	1600
	45kg	160	102	1210
	80kg	74	46	620
導程 12 Lead	10kg	645	470	2040
	30kg	193	141	638
	60kg	80	58	283
導程 24 Lead	20kg	133	145	253
	40kg	55	60	109
	-	-	-	-

垂直安裝 Vertical Installation		A	C
導程 6 Lead	10kg	535	535
	15kg	360	360
	-	-	-
導程 12 Lead	3.5kg	1380	1380
	8kg	605	605
	-	-	-
導程 24 Lead	2kg	1380	1380
	5kg	556	556
	-	-	-

靜額定扭矩 Static Loading Moment

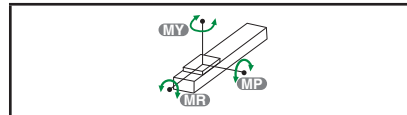

(單位 Unit: N.m)

MY	137
MP	137
MR	227

* 力矩表所表示的數據，代表荷重的重心位置於單方向容許懸出的長度。The data represented by the moment table is the center of gravity of the load. The length of the overhang is allowed in a single direction.

* 符合型錄規範的正常使用下，保證壽命為 10000 公里。

Operation life is not for ceiling-mount inverse use. The data information is not for ceiling-mount inverse use.

* 倒吊使用無法套用標準規範，如有需求請洽詢我司業務。

Data information is not for ceiling-mount inverse use. Contact us for the details if you want to apply ceiling-mount inverse use.

* 壽命及力矩是以馬達加速減速設定 0.2 秒計算。

The life and torque are calculated by setting the motor acceleration and deceleration for 0.2 seconds.

選配 Options

MM

指定馬達出線方向 Selectable Cable Leading Direction		
代號 Code	說明 Instructions	需參照 Refer to
MW	朝上 Upper side	P.111 ~ P.112
MM	朝下 Bottom side	
ML	朝左 Left side	
MR	朝右 Right side	

CMK

馬達傳動配件追加鍵槽 Additional keyway for motor drive parts				
代號 Code	說明 Instructions			需參照 Refer to
	追加鍵槽 Keyway Groove	馬達位置 Motor Position	出貨型式 Shipment Type	
CMK	單邊 (限定馬達側) Single (Limited to the motor side)	BC	鍵槽式聯軸器 Keyway Coupling	P.113 ~ P.115
		BL/BR/BM	鍵槽式皮帶輪 Keyway Belt Pulley	
SKY	雙邊 Double	BC	鍵槽式聯軸器 Keyway Coupling	
		BL/BR/BM	鍵槽式皮帶輪 Keyway Belt Pulley	
SKN	雙邊 Double	BC	無聯軸器 (請自行購買安裝) Without Coupling (Please purchase and install by yourself)	
		BL/BR/BM	無馬達端皮帶輪 (請自行購買安裝) Without Belt Pulley (Please purchase and install by yourself)	

GLTH Series

- GLTH3
- GLTH5
- GLTH8
- GLTH12
- GLTH5D
- GLTH8D
- GLMH5
- GLMH8
- GLTH5M
- GLTH8M

GLTH8M 單軸 /1-axis

▶ 軌道內嵌
Integrated Linear Bearing

▶ 螺桿驅動
Ball Screw Drive



Download at www.toyorobot.com

BC 馬達外露 Motor Exposed

單位 Unit : mm

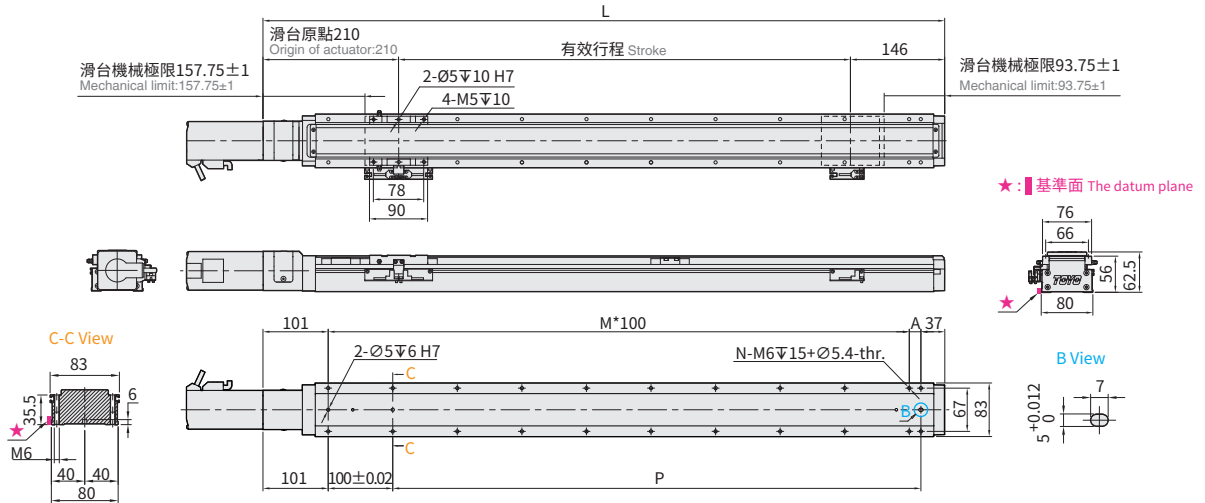

BM 馬達下折 Motor Bottom Side

單位 Unit : mm

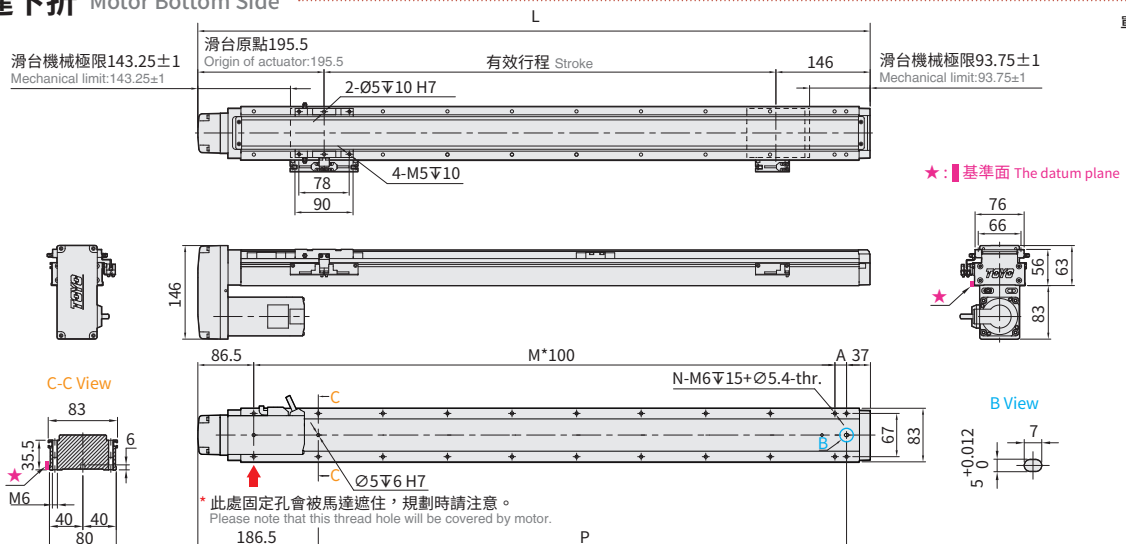

有效行程 Stroke	700	750	800	850	900	950	1000	1050	1100	1150	1200	1250	1300	1350	1400	1450	1500	1550	1600	1650		
極限行程 Limit Stroke (±1)	714.5	764.5	814.5	864.5	914.5	964.5	1014.5	1064.5	1114.5	1164.5	1214.5	1264.5	1314.5	1364.5	1414.5	1464.5	1514.5	1564.5	1614.5	1664.5		
L	BC	1056	1106	1156	1206	1256	1306	1356	1406	1456	1506	1556	1606	1656	1706	1756	1806	1856	1906	1956	2006	
	BM	1041.5	1091.5	1141.5	1191.5	1241.5	1291.5	1341.5	1391.5	1441.5	1491.5	1541.5	1591.5	1641.5	1691.5	1741.5	1791.5	1841.5	1891.5	1941.5	1991.5	
A	18	68	18	68	18	68	18	68	18	68	18	68	18	68	18	68	18	68	18	68	68	
M	9	9	10	10	11	11	12	12	13	13	14	14	15	15	16	16	17	17	18	18	18	
N	22	22	24	24	26	26	28	28	30	30	32	32	34	34	36	36	38	38	40	40	40	
P	818	868	918	968	1018	1068	1118	1168	1218	1268	1318	1368	1418	1468	1518	1568	1618	1668	1718	1768	1768	
KG	BC	6.68	6.93	7.19	7.46	7.71	7.97	8.22	8.47	8.74	8.99	9.24	9.5	9.75	10.02	10.29	10.55	10.82	11.06	11.3	11.56	
	BM	6.88	7.13	7.39	7.66	7.91	8.17	8.42	8.67	8.94	9.19	9.44	9.7	9.95	10.22	10.49	10.75	11.02	11.26	11.51	11.76	
線速度 Linear Speed mm/s	導程 Lead 6	360																				
	導程 Lead 12	720																				
	導程 Lead 24	1440																				
有效行程 Stroke	1700	1750	1800	1850	1900	1950	2000	2050	2100	2150	2200	2250	2300	2350	2400	2450	2500					
	極限行程 Limit Stroke (±1)	1714.5	1764.5	1814.5	1864.5	1914.5	1964.5	2014.5	2064.5	2114.5	2164.5	2214.5	2264.5	2314.5	2364.5	2414.5	2464.5	2514.5				
L	BC	2056	2106	2156	2206	2256	2306	2356	2406	2456	2506	2556	2606	2656	2706	2756	2806	2856				
	BM	2041.5	2091.5	2141.5	2191.5	2241.5	2291.5	2341.5	2391.5	2441.5	2491.5	2541.5	2591.5	2641.5	2691.5	2741.5	2791.5	2841.5				
A	18	68	18	68	18	68	18	68	18	68	18	68	18	68	18	68	18	68	18	68	18	
M	19	19	20	20	21	21	22	22	23	23	24	24	25	25	26	26	27					
N	42	42	44	44	46	46	48	48	50	50	52	52	54	54	56	56	58					
P	1818	1868	1918	1968	2018	2068	2118	2168	2218	2268	2318	2368	2418	2468	2518	2568	2618					
KG	BC	11.82	12.07	12.33	12.58	12.84	13.1	13.35	13.61	13.87	14.12	14.38	14.64	14.89	15.15	15.4	15.66	15.92				
	BM	12.02	12.27	12.53	12.78	13.04	13.3	13.55	13.81	14.07	14.32	14.58	14.84	15.09	15.35	15.61	15.86	16.12				
線速度 Linear Speed mm/s	導程 Lead 6	170	160	150	140	130	120	110	100	90	80	70	60									
	導程 Lead 12	340	320	300	280	260	240	220	200	180	160	140	120									
	導程 Lead 24	680	640	600	560	520	480	440	400	360	320	280	240									



Download at www.toyorobot.com

BL 馬達左折 Motor Left Side

單位 Unit : mm

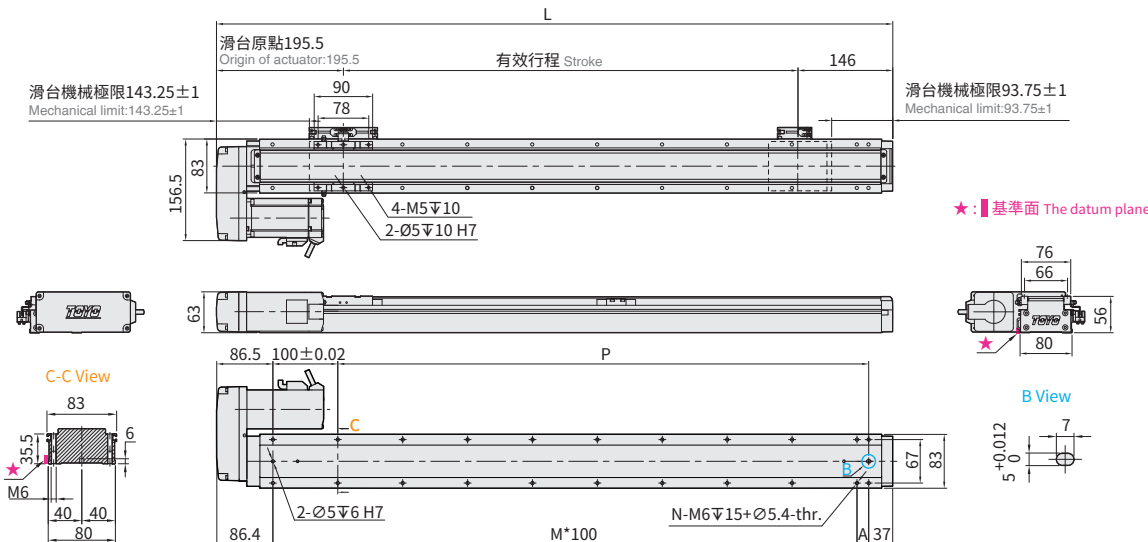

BR 馬達右折 Motor Right Side

單位 Unit : mm

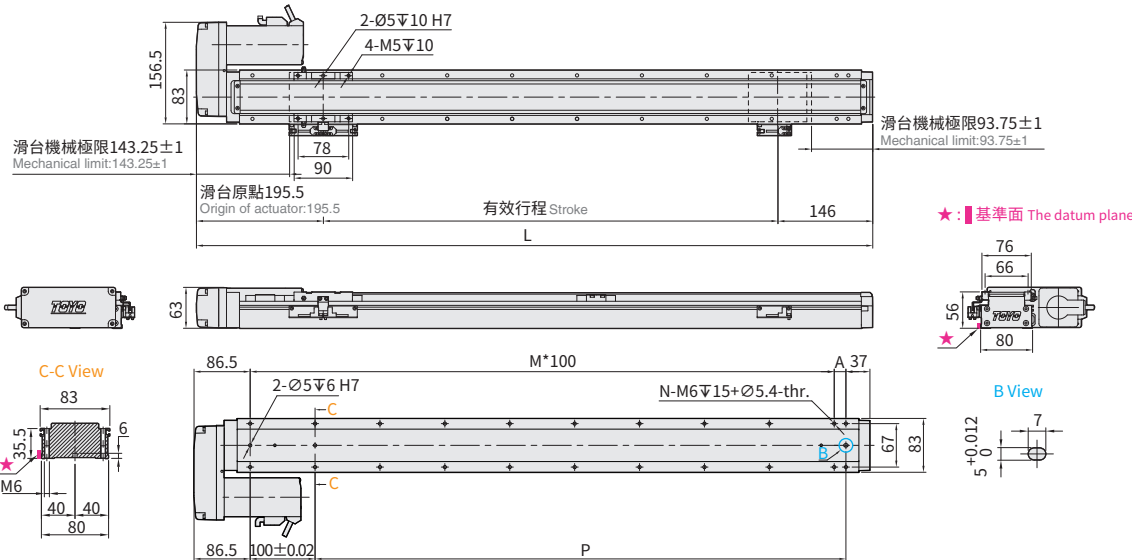

有效行程 Stroke	700	750	800	850	900	950	1000	1050	1100	1150	1200	1250	1300	1350	1400	1450	1500	1550	1600	1650		
極限行程 Limit Stroke (±1)	714.5	764.5	814.5	864.5	914.5	964.5	1014.5	1064.5	1114.5	1164.5	1214.5	1264.5	1314.5	1364.5	1414.5	1464.5	1514.5	1564.5	1614.5	1664.5		
L	1041.5	1091.5	1141.5	1191.5	1241.5	1291.5	1341.5	1391.5	1441.5	1491.5	1541.5	1591.5	1641.5	1691.5	1741.5	1791.5	1841.5	1891.5	1941.5	1991.5		
A	18	68	18	68	18	68	18	68	18	68	18	68	18	68	18	68	18	68	18	68		
M	9	9	10	10	11	11	12	12	13	13	14	14	15	15	16	16	17	17	18	18		
N	22	22	24	24	26	26	28	28	30	30	32	32	34	34	36	36	38	38	40	40		
P	818	868	918	968	1018	1068	1118	1168	1218	1268	1318	1368	1418	1468	1518	1568	1618	1668	1718	1768		
BM	6.88	7.13	7.39	7.66	7.91	8.17	8.42	8.67	8.94	9.19	9.44	9.7	9.95	10.22	10.49	10.75	11.02	11.26	11.51	11.76		
線速度 Linear Speed mm/s																						
	導程 Lead 6											320	300	280	260	250	230	220	210	200	190	180
	導程 Lead 12											640	600	560	520	500	460	440	420	400	380	360
導程 Lead 24											1280	1200	1120	1040	1000	920	880	840	800	760	720	

有效行程 Stroke	1700	1750	1800	1850	1900	1950	2000	2050	2100	2150	2200	2250	2300	2350	2400	2450	2500
極限行程 Limit Stroke (±1)	1714.5	1764.5	1814.5	1864.5	1914.5	1964.5	2014.5	2064.5	2114.5	2164.5	2214.5	2264.5	2314.5	2364.5	2414.5	2464.5	2514.5
L	2041.5	2091.5	2141.5	2191.5	2241.5	2291.5	2341.5	2391.5	2441.5	2491.5	2541.5	2591.5	2641.5	2691.5	2741.5	2791.5	2841.5
A	18	68	18	68	18	68	18	68	18	68	18	68	18	68	18	68	18
M	19	19	20	20	21	21	22	22	23	23	24	24	25	25	26	26	27
N	42	42	44	44	46	46	48	48	50	50	52	52	54	54	56	56	58
P	1818	1868	1918	1968	2018	2068	2118	2168	2218	2268	2318	2368	2418	2468	2518	2568	2618
KG	12.02	12.27	12.53	12.78	13.04	13.3	13.55	13.81	14.07	14.32	14.58	14.84	15.09	15.35	15.61	15.86	16.12
線速度 Linear Speed mm/s																	
	導程 Lead 6	170	160	150	140	130	120	110	100	90	80	70	60	50	40	30	20
	導程 Lead 12	340	320	300	280	260	240	220	200	180	160	140	120	100	80	60	40
導程 Lead 24	680	640	600	560	520	480	440	400	360	320	280	240	200	160	120	80	

- 應用例 Application
- 一般 / 螺桿仕様 GLTH
- 一般 / 皮帶仕様 ETB / M
- 無塵 / 螺桿仕様 GCH / ECH
- 無塵 / 皮帶仕様 ECB
- 直交連結 XYGT / XYTH / XYTB
- 參考資料 Reference

- GLTH Series
- GLTH3
 - GLTH5
 - GLTH8
 - GLTH12
 - GLTH5D
 - GLTH8D
 - GLMH5
 - GLMH8
 - GLTH5M
 - GLTH8M

GLTH8M 單軸 /1-axis

▶ 軌道內嵌
Integrated Linear Bearing

▶ 螺桿驅動
Ball Screw Drive

精度
±0.005 mm



最大行程
Maximum Stroke 2500mm

最高速度
Maximum Speed 1440mm/s

馬達容量
Motor Output 400W

最大可搬重量
Max Payload 105kg

型號表示方式 Ordering Method

GLTH8M - L6 - 700 - BC - M40B - C4N5 - 參照右頁
Refer to the right page. - 0001

本體型號
Model

行程
Stroke

700-2500mm
50間隔 50 mm Pitch

選配
Options

特注式樣
Customization Order No.

螺桿導程
Ball Screw Lead

6	6mm
12	12mm
24	24mm

馬達位置
Motor Position

BC	馬達外露 Motor Exposed
BM	馬達下折 Motor Bottom Side
BL	馬達左折 Motor Left Side
BR	馬達右折 Motor Right Side

馬達廠牌、功率
Motor Brand · Power Output

M	三菱 Mitsubishi	05	-	B ^{*2}
P	松下 Panasonic	10	-	
Y	安川 Yaskawa	20	-	
T	台達 Delta	40	400W	

原點感應器
Home Sensor

外掛型 Out Side	
C	馬達側 Motor Side
D	反馬達側 Opposite Motor Side
無 SENSOR No Sensor	
E	無 SENSOR No Sensor

端點極限感應器
Limit Sensor

外掛型 Out Side	
3	1只 1 Pc
4	2只 2 Pcs
6	3只 3 Pcs
7	4只 4 Pcs
8	5只 5 Pcs
9	6只 6 Pcs
無 SENSOR No Sensor	
5	無 SENSOR No Sensor

輸出方式&線長
Output type & Cable length

N5	NPN+5米線 NPN+5M Cable
P2	PNP+2米線 PNP+2M Cable
P5	PNP+5米線 PNP+5M Cable
-	NPN+2米線 NPN+2M Cable

*2 馬達若無煞車則不表示。 If Motor No Brake, No Description.

基本仕様 Specification

性能	位置重複精度 Repeatability	mm	±0.005			
	螺桿導程 Lead	mm	6	12	24	
	最高轉速 Maximum Rotating speed	rpm	3600	3600	3600	
	最高速度 Maximum linear speed ^{※1}	mm/s	360	720	1440	
	最大可搬重量 ^{※2} Maximum Payload	水平使用 Horizontal	kg	105	85	40
		垂直使用 Vertical	kg	30	20	10
	定格推力 Rated Thrust	N	1156	578	289	
	標準行程 Stroke (increments)	mm	700-2500mm / 50 間隔 (50 increments)			
	最大加速度 Maximum acceleration	G	0.37	0.73	1.47	
	滾珠螺桿 Ball screw	基本動額定負荷 Basic dynamic load rating Ca	N	7733	5855	3007
基本靜額定負荷 Basic static load rating Coa		N	14200	10401	5414	
直線滑軌 Linear Guide	動態水平負載 Dynamic horizontal (100km)	N	18601			
	靜態水平負載 Static Horizontal	N	34189			
固定側軸承 Fixed bearing	基本動額定負荷 Basic dynamic load rating Cr	N	8447			
	靜態容許負荷 Static load rating Cor	N	5060			
部品	AC 伺服馬達容量 AC Servo Motor Output	W	400			
	滾珠螺桿外徑 Ball Screw Ø	mm	C7Ø14			
	連軸器 Coupling	mm	10X14			
	原點感應器 Home Sensor	外掛 Outside	T64N2 (NPN+2 米線) (NPN+2M Cable)			

※1 長行程時，會產生螺桿偏擺，需將速度調降 (線速度請參閱尺寸圖下方表格)

During in a long stroke, it causes ballscrew deflection, the speed must reduce. (Please refer to the linear velocity from the data sheet below the dimension graph.)

※2 由於各廠牌的馬達性能不同，需速度搭配回升電阻以達到此荷重條件。

Since the motor performance of each brand is different, a regenerative resistor needs to be appropriately matched to achieve this load condition.

容許負載力距表 Allowable Overhang

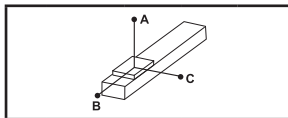

(單位 Unit: mm)

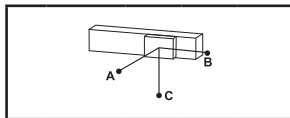

(單位 Unit: mm)

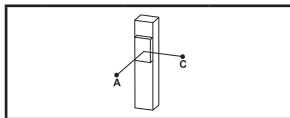

(單位 Unit: mm)

水平安裝 Horizontal Installation		A	B	C
導程 6 Lead	30kg	1900	165	261
	50kg	1080	88	140
	105kg	434	29	47
導程 12 Lead	25kg	780	175	240
	35kg	530	117	160
	85kg	175	33	46
導程 24 Lead	4kg	1400	820	750
	12kg	440	257	235
	40kg	109	60	55

壁掛安裝 Wall Installation		A	B	C
導程 6 Lead	30kg	261	165	1900
	50kg	140	88	1080
	105kg	47	29	434
導程 12 Lead	25kg	240	175	780
	35kg	160	117	530
	85kg	46	33	175
導程 24 Lead	4kg	750	820	1400
	12kg	235	257	440
	40kg	55	60	109

垂直安裝 Vertical Installation		A	C
導程 6 Lead	16kg	335	335
	30kg	180	180
	-	-	-
導程 12 Lead	12kg	400	400
	20kg	240	240
	-	-	-
導程 24 Lead	6kg	460	460
	10kg	275	275
	-	-	-

靜額定扭矩 Static Loading Moment

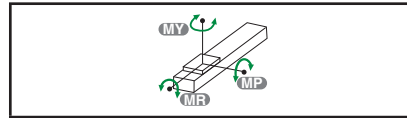

(單位 Unit: N.m)

MY	137
MP	137
MR	227

* 力矩表所表示的數據，代表荷重的重心位置於單方向容許懸出的長度。
The data represented by the moment table is the center of gravity of the load. The length of the overhang is allowed in a single direction.

* 符合型錄規範的正常使用下，保證壽命為 10000 公里。
Operation life is 10,000km when the product is using under the specified conditions.

* 倒吊使用無法套用標準規範，如有需求請洽詢我司業務。
Data information is not for ceiling-mount inverse use. Contact us for the details if you want to apply ceiling-mount inverse usage.

* 壽命及力矩是以馬達加減速設定 0.2 秒計算。
The life and torque are calculated by setting the motor acceleration and deceleration for 0.2 seconds.

選配 Options

MM

指定馬達出線方向 Selectable Cable Leading Direction		
代號 Code	說明 Instructions	需參照 Refer to
MW	朝上 Upper side	P.111 ~ P.112
MM	朝下 Bottom side	
ML	朝左 Left side	
MR	朝右 Right side	

CMK

馬達傳動配件追加鍵槽 Additional keyway for motor drive parts				
代號 Code	說明 Instructions			需參照 Refer to
	追加鍵槽 Keyway Groove	馬達位置 Motor Position	出貨型式 Shipment Type	
CMK	單邊 (限定馬達側) Single (Limited to the motor side)	BC	鍵槽式聯軸器 Keyway Coupling	P.113 ~ P.115
		BL/BR/BM	鍵槽式皮帶輪 Keyway Belt Pulley	
SKY	雙邊 Double	BC	鍵槽式聯軸器 Keyway Coupling	
		BL/BR/BM	鍵槽式皮帶輪 Keyway Belt Pulley	
SKN	雙邊 Double	BC	無聯軸器 (請自行購買安裝) Without Coupling (Please purchase and install by yourself)	
		BL/BR/BM	無馬達端皮帶輪 (請自行購買安裝) Without Belt Pulley (Please purchase and install by yourself)	

GLTH Series

- GLTH3
- GLTH5
- GLTH8
- GLTH12
- GLTH5D
- GLTH8D
- GLMH5
- GLMH8
- GLTH5M
- GLTH8M

GLTH8M 單軸 /1-axis

▶ 軌道內嵌
Integrated Linear Bearing

▶ 螺桿驅動
Ball Screw Drive



Download at www.toyorobot.com

BC 馬達外露 Motor Exposed

單位 Unit : mm

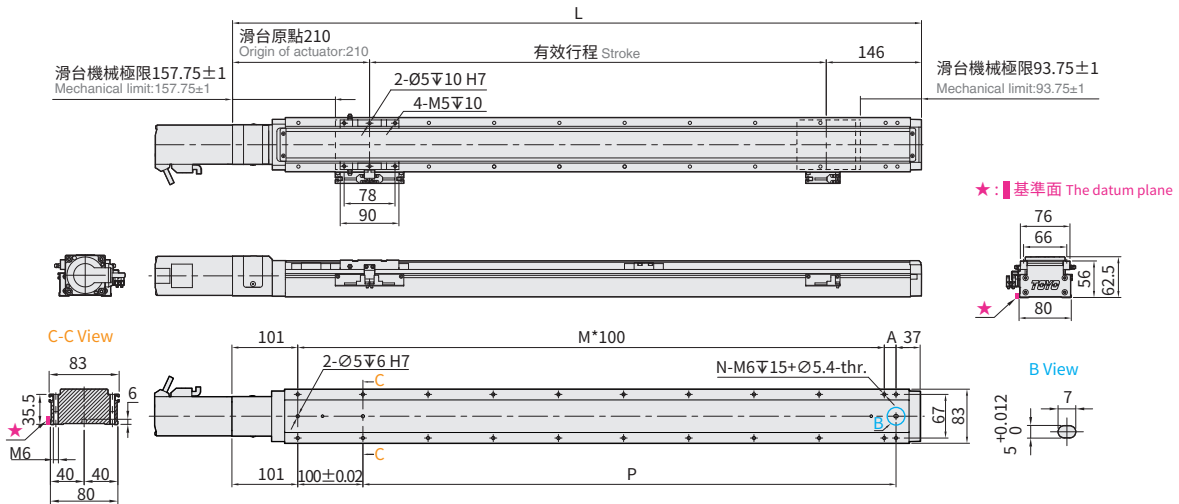

BM 馬達下折 Motor Bottom Side

單位 Unit : mm

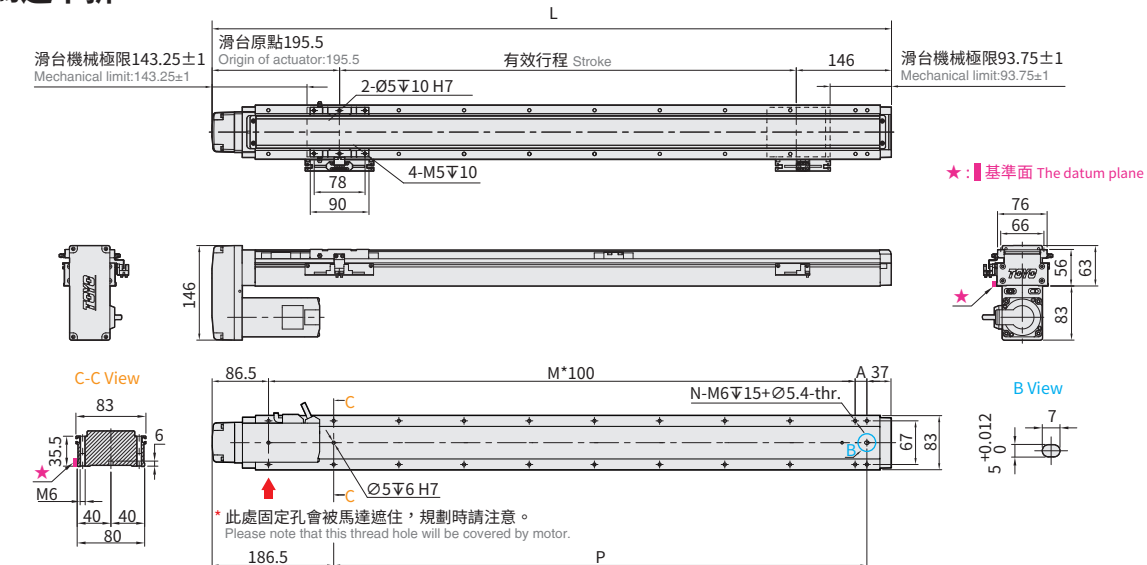

有效行程 Stroke	700	750	800	850	900	950	1000	1050	1100	1150	1200	1250	1300	1350	1400	1450	1500	1550	1600	1650	
極限行程 Limit Stroke (±1)	714.5	764.5	814.5	864.5	914.5	964.5	1014.5	1064.5	1114.5	1164.5	1214.5	1264.5	1314.5	1364.5	1414.5	1464.5	1514.5	1564.5	1614.5	1664.5	
L	BC	1056	1106	1156	1206	1256	1306	1356	1406	1456	1506	1556	1606	1656	1706	1756	1806	1856	1906	1956	2006
	BM	1041.5	1091.5	1141.5	1191.5	1241.5	1291.5	1341.5	1391.5	1441.5	1491.5	1541.5	1591.5	1641.5	1691.5	1741.5	1791.5	1841.5	1891.5	1941.5	1991.5
A	18	68	18	68	18	68	18	68	18	68	18	68	18	68	18	68	18	68	18	68	18
M	9	9	10	10	11	11	12	12	13	13	14	15	15	16	16	17	17	17	18	18	18
N	22	22	24	24	26	26	28	28	30	30	32	32	34	34	36	36	38	38	40	40	40
P	818	868	918	968	1018	1068	1118	1168	1218	1268	1318	1368	1418	1468	1518	1568	1618	1668	1718	1768	
KG	BC	6.68	6.93	7.19	7.46	7.71	7.97	8.22	8.47	8.74	8.99	9.24	9.5	9.75	10.02	10.29	10.55	10.82	11.06	11.3	11.56
	BM	6.88	7.13	7.39	7.66	7.91	8.17	8.42	8.67	8.94	9.19	9.44	9.7	9.95	10.22	10.49	10.75	11.02	11.26	11.51	11.76
線速度 Linear Speed mm/s	導程 Lead 6	360																			
	導程 Lead 12	720																			
	導程 Lead 24	1440																			
有效行程 Stroke	1700	1750	1800	1850	1900	1950	2000	2050	2100	2150	2200	2250	2300	2350	2400	2450	2500				
極限行程 Limit Stroke (±1)	1714.5	1764.5	1814.5	1864.5	1914.5	1964.5	2014.5	2064.5	2114.5	2164.5	2214.5	2264.5	2314.5	2364.5	2414.5	2464.5	2514.5				
L	BC	2056	2106	2156	2206	2256	2306	2356	2406	2456	2506	2556	2606	2656	2706	2756	2806	2856			
	BM	2041.5	2091.5	2141.5	2191.5	2241.5	2291.5	2341.5	2391.5	2441.5	2491.5	2541.5	2591.5	2641.5	2691.5	2741.5	2791.5	2841.5			
A	18	68	18	68	18	68	18	68	18	68	18	68	18	68	18	68	18				
M	19	19	20	20	21	21	22	22	23	23	24	24	25	25	26	26	27				
N	42	42	44	44	46	46	48	48	50	50	52	52	54	54	56	56	58				
P	1818	1868	1918	1968	2018	2068	2118	2168	2218	2268	2318	2368	2418	2468	2518	2568	2618				
KG	BC	11.82	12.07	12.33	12.58	12.84	13.1	13.35	13.61	13.87	14.12	14.38	14.64	14.89	15.15	15.4	15.66	15.92			
	BM	12.02	12.27	12.53	12.78	13.04	13.3	13.55	13.81	14.07	14.32	14.58	14.84	15.09	15.35	15.61	15.86	16.12			
線速度 Linear Speed mm/s	導程 Lead 6	170	160	150	140	130	120				110	100	90	80	70	60					
	導程 Lead 12	340	320	300	280	260	240				220	200	180	160	140	120					
	導程 Lead 24	680	640	600	560	520	480				440	400	360	320	280	240					



Download at www.toyorobot.com

BL 馬達左折 Motor Left Side

單位 Unit : mm

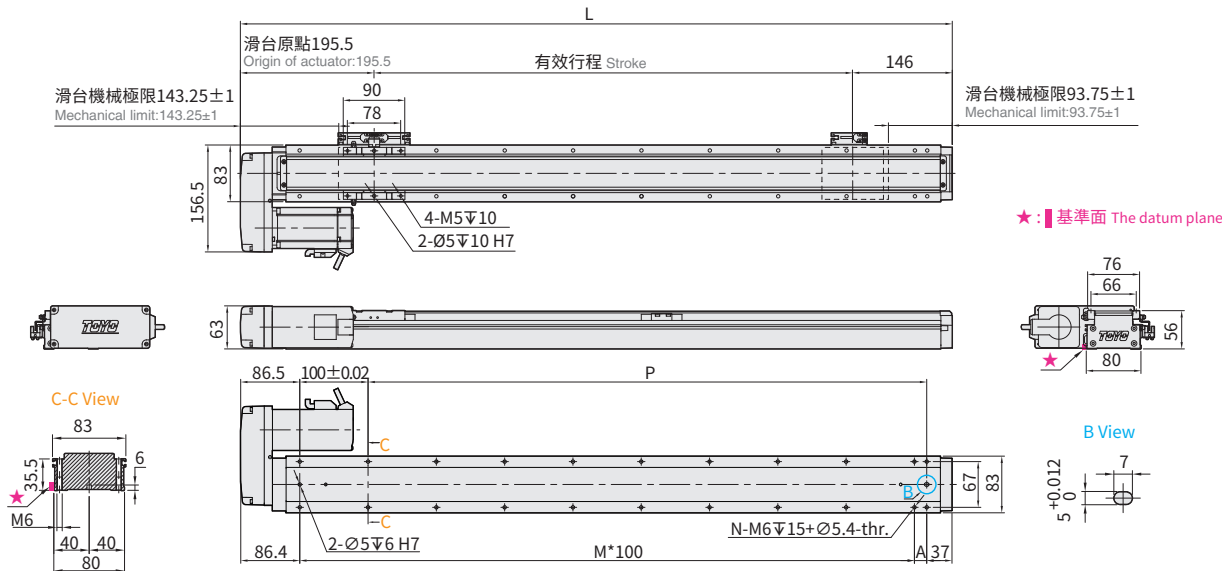

BR 馬達右折 Motor Right Side

單位 Unit : mm

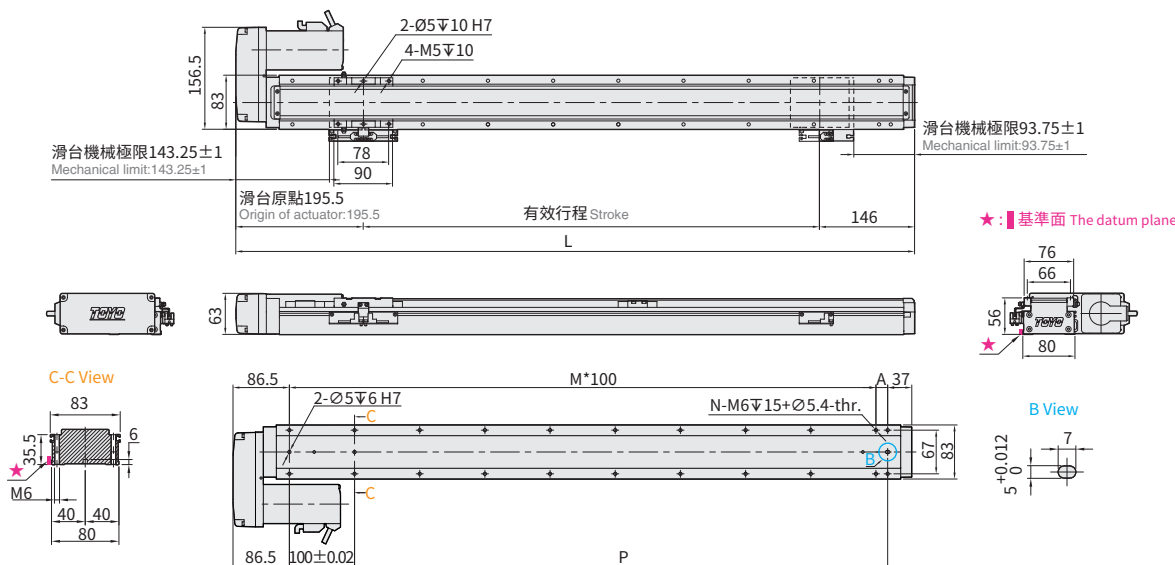

有效行程 Stroke	700	750	800	850	900	950	1000	1050	1100	1150	1200	1250	1300	1350	1400	1450	1500	1550	1600	1650				
極限行程 Limit Stroke (±1)	714.5	764.5	814.5	864.5	914.5	964.5	1014.5	1064.5	1114.5	1164.5	1214.5	1264.5	1314.5	1364.5	1414.5	1464.5	1514.5	1564.5	1614.5	1664.5				
L	1041.5	1091.5	1141.5	1191.5	1241.5	1291.5	1341.5	1391.5	1441.5	1491.5	1541.5	1591.5	1641.5	1691.5	1741.5	1791.5	1841.5	1891.5	1941.5	1991.5				
A	18	68	18	68	18	68	18	68	18	68	18	68	18	68	18	68	18	68	18	68				
M	9	9	10	10	11	11	12	12	13	13	14	14	15	15	16	16	17	17	18	18				
N	22	22	24	24	26	26	28	28	30	30	32	32	34	34	36	36	38	38	40	40				
P	818	868	918	968	1018	1068	1118	1168	1218	1268	1318	1368	1418	1468	1518	1568	1618	1668	1718	1768				
BM	KG	6.88	7.13	7.39	7.66	7.91	8.17	8.42	8.67	8.94	9.19	9.44	9.7	9.95	10.22	10.49	10.75	11.02	11.26	11.51	11.76			
線速度 Linear Speed mm/s	導程 Lead 6	360																						
	導程 Lead 12	720																						
	導程 Lead 24	1440																						
		320	300	280	260	250	230	220	210	200	190	180	170	160	150	140	130	120	110	100	90	80	70	60
		640	600	560	520	500	460	440	420	400	380	360	340	320	300	280	260	240	220	200	180	160	140	120
		1280	1200	1120	1040	1000	920	880	840	800	760	720	680	640	600	560	520	480	440	400	360	320	280	240

有效行程 Stroke	1700	1750	1800	1850	1900	1950	2000	2050	2100	2150	2200	2250	2300	2350	2400	2450	2500
極限行程 Limit Stroke (±1)	1714.5	1764.5	1814.5	1864.5	1914.5	1964.5	2014.5	2064.5	2114.5	2164.5	2214.5	2264.5	2314.5	2364.5	2414.5	2464.5	2514.5
L	2041.5	2091.5	2141.5	2191.5	2241.5	2291.5	2341.5	2391.5	2441.5	2491.5	2541.5	2591.5	2641.5	2691.5	2741.5	2791.5	2841.5
A	18	68	18	68	18	68	18	68	18	68	18	68	18	68	18	68	18
M	19	19	20	20	21	21	22	22	23	23	24	24	25	25	26	26	27
N	42	42	44	44	46	46	48	48	50	50	52	52	54	54	56	56	58
P	1818	1868	1918	1968	2018	2068	2118	2168	2218	2268	2318	2368	2418	2468	2518	2568	2618
KG	12.02	12.27	12.53	12.78	13.04	13.3	13.55	13.81	14.07	14.32	14.58	14.84	15.09	15.35	15.61	15.86	16.12
線速度 Linear Speed mm/s	導程 Lead 6	170															
	導程 Lead 12	340															
	導程 Lead 24	680															
		160	150	140	130	120	110	100	90	80	70	60	50	40	30	20	10
		320	300	280	260	240	220	200	180	160	140	120	100	80	60	40	20
		640	600	560	520	480	440	400	360	320	280	240	200	160	120	80	40

- 應用例 Application
- 一般 / 螺桿仕様 GLTH
- 一般 / 皮帶仕様 ETB / M
- 無塵 / 螺桿仕様 GCH / ECH
- 無塵 / 皮帶仕様 ECB
- 直交連結 XYGT / XTH / XYTB
- 參考資料 Reference

- GLTH Series
- GLTH3
 - GLTH5
 - GLTH8
 - GLTH12
 - GLTH5D
 - GLTH8D
 - GLMH5
 - GLMH8
 - GLTH5M
 - GLTH8M

GLTB5 單軸 /1-axis

▶ 軌道內嵌
Integrated Linear Bearing

▶ 皮帶驅動
Belt Driver

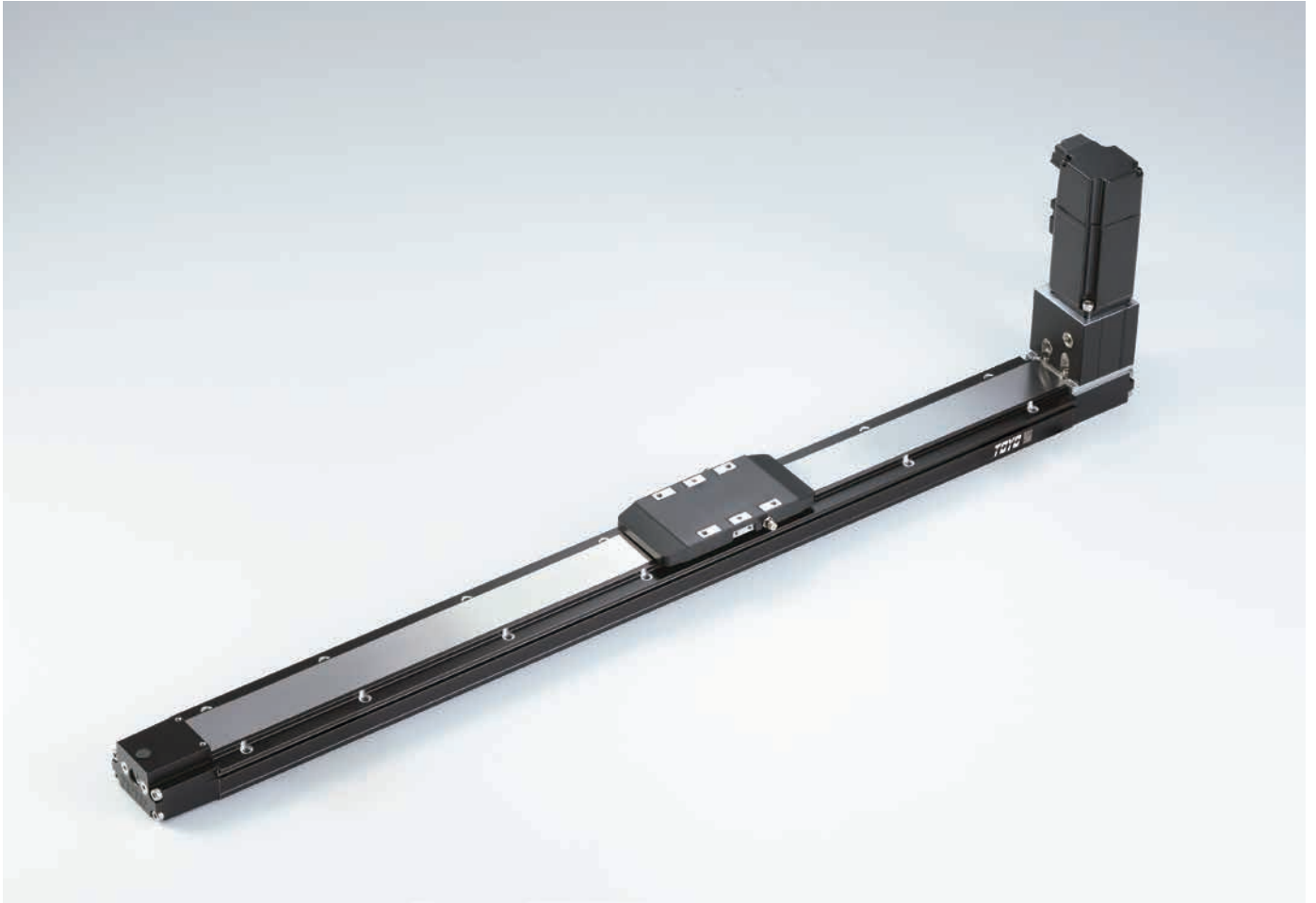

最大行程
Maximum Stroke **3000mm**

最高速度
Maximum Speed **1067mm/s**

馬達容量
Motor Output **100W**

最大可搬重量
Max Payload **5kg**

型號表示方式 Ordering Method

GLTB5 - X32 - 500 - BM - M10 - C4N5 - 參照右頁
Refer to the right page. - 0001

本體型號
Model

導程
Lead

32 32mm

行程^{*1}
Stroke

50-3000mm
50間隔 50 mm Pitch

選配
Options

特注式樣
Customization Order No.

皮帶型式
Belt Type

X 橡膠皮帶
Rubber belt

馬達位置
Motor Position

BW 馬達上折
Motor Top Side
BM 馬達下折
Motor Bottom Side

馬達廠牌、功率
Motor Brand · Power Output

M	三菱 Mitsubishi	05	-
P	松下 Panasonic	10	100W
Y	安川 Yaskawa	20	-
T	台達 Delta	40	-

原點感應器
Home Sensor

外掛型 Out Side	
C	馬達側 Motor Side
D	反馬達側 Opposite Motor Side
無 SENSOR No Sensor	
E	無 SENSOR No Sensor

端點極限感應器
Limit Sensor

外掛型 Out Side	
3	1只 1 Pc
4	2只 2 Pcs
6	3只 3 Pcs
7	4只 4 Pcs
8	5只 5 Pcs
9	6只 6 Pcs
無 SENSOR No Sensor	
5	無 SENSOR No Sensor

輸出方式&線長
Output type & Cable length

N5	NPN+5米線 NPN+5M Cable
P2	PNP+2米線 PNP+2M Cable
P5	PNP+5米線 PNP+5M Cable
-	NPN+2米線 NPN+2M Cable

*1 選擇行程50時，光電使用有以下限制：When the stroke is 50mm, the sensor installation has the following restrictions:

1. 原點與極限需放置於不同側。2. 滑座左右兩側皆需安裝感應片。 Motor Direction BC/BM 1.Home sensor and limit sensor has to be installed on the different side of body. 2.Both sides of slider need to install the sensor trigger device.
1. 原點+極限感應器最數量最多2只 (僅能選用C3/D3/E3/E4/E5)。 Motor Direction BL/BR 1.Home + limit sensors is 2 maximum (only C3/D3/E3/E4/E5 can be selected)

基本仕様 Specification

性能	位置重複精度 Repeatability	mm	±0.06	
	導程 Lead	mm	32	
	最高轉速 Maximum Rotating speed	rpm	2000	
	最高速度 Maximum linear speed	mm/s	1067	
	最大可搬重量 Maximum Payload	水平使用 Horizontal	kg	5
		垂直使用 Vertical	kg	
	定格推力 Rated Thrust	N	53	
	標準行程 Stroke (increments)	mm	50-3000mm / 50 間隔 (50 increments)	
	最大加速度 Maximum acceleration	G	0.27	
部品	AC 伺服馬達容量 AC Servo Motor Output	W	100	
	皮帶寬度 Belt Width	mm	9	
	原點感應器 Home Sensor	外掛 Outside	T64N2 (NPN+2 米線) (NPN+2M Cable)	

容許負載力距表 Allowable Overhang

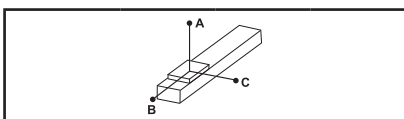

(單位 Unit: mm)

水平安裝 Horizontal Installation	A	B	C
2kg	622	64	65
3kg	380	36	38
5kg	168	14	15

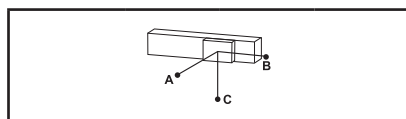

(單位 Unit: mm)

壁掛安裝 Wall Installation	A	B	C
2kg	65	64	622
3kg	38	36	380
5kg	15	14	168

靜額定扭矩 Static Loading Moment

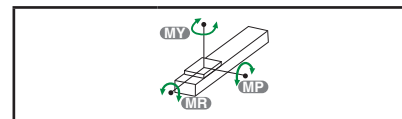

(單位 Unit: N.m)

MY	73
MP	73
MR	115

* 力矩表所表示的數據，代表荷重的重心位置於單一方向容許懸出的長度。
The data represented by the moment table is the center of gravity of the load. The length of the overhang is allowed in a single direction.
* 符合型錄規範的正常使用下，保證壽命為 10000 公里。
Operation life is 10,000km when the product is using under the specified conditions.
* 倒吊使用無法套用標準規範，如有需求請洽詢我司業務。
Data information is not for ceiling-mount inverse use. Contact us for the details if you want to apply ceiling-mount inverse usage.
* 壽命及力矩是以馬達加速減速設定 0.4 秒計算。
The life and torque are calculated by setting the motor acceleration and deceleration for 0.4 seconds.

選配 Options

MM

指定馬達出線方向 Selectable Cable Leading Direction		
代號 Code	說明 Instructions	需參照 Refer to
MW	朝上 Upper side	P.111 ~ P.112
MM	朝下 Bottom side	
ML	朝左 Left side	
MR	朝右 Right side	

CMK

馬達傳動配件追加鍵槽 Additional keyway for motor drive parts			
代號 Code	說明 Instructions		需參照 Refer to
	追加鍵槽 Keyway Groove	出貨型式 Shipment Type	
CMK	單邊 (限定馬達側) Single (Limited to the motor side)	鍵槽式皮帶輪 Keyway Belt Pulley	P.113 ~ P.115

免費服務專線：台灣 **0800-800-893**
Toll-Free Number Taiwan

Memo

應用例
Application

一般 / 螺桿仕様
GTH / GTY / ETH / Y

一般 / 皮帶仕様
GLTB

無塵 / 螺桿仕様
GCH / ECH

無塵 / 皮帶仕様
ECB

直交連結
XYGT / XTH / XYTB

參考資料
Reference

GLTB Series

GLTB5

GLTB8

GLTB8 單軸 /1-axis

▶ 軌道內嵌
Integrated Linear Bearing

▶ 皮帶驅動
Belt Driver



最大行程
Maximum Stroke **3000mm**

最高速度
Maximum Speed **2000mm/s**

馬達容量
Motor Output **400W**

最大可搬重量
Max Payload **8kg**

型號表示方式 Ordering Method

GLTB8 - X60 - 500 - BM - M40 - C4N5 - 參照右頁
Refer to the right page. - 0001

本體型號
Model

導程
Lead

60 60mm

行程^{*1}
Stroke

50-3000mm
50間隔 50 mm Pitch

選配
Options

特注式樣
Customization Order No.

皮帶型式
Belt Type

X 橡膠皮帶
Rubber belt

馬達位置
Motor Position

BW 馬達上折
Motor Top Side
BM 馬達下折
Motor Bottom Side

馬達廠牌、功率
Motor Brand · Power Output

M	三菱 Mitsubishi	05	-
P	松下 Panasonic	10	-
Y	安川 Yaskawa	20	-
T	台達 Delta	40	400W

原點感應器
Home Sensor

外掛型 Out Side	
C	馬達側 Motor Side
D	反馬達側 Opposite Motor Side
無 SENSOR No Sensor	
E	無 SENSOR No Sensor

端點極限感應器
Limit Sensor

外掛型 Out Side	
3	1只 1 Pc
4	2只 2 Pcs
6	3只 3 Pcs
7	4只 4 Pcs
8	5只 5 Pcs
9	6只 6 Pcs
無 SENSOR No Sensor	
5	無 SENSOR No Sensor

輸出方式&線長
Output type & Cable length

N5	NPN+5米線 NPN+5M Cable
P2	PNP+2米線 PNP+2M Cable
P5	PNP+5米線 PNP+5M Cable
-	NPN+2米線 NPN+2M Cable

*1 選擇行程50時，光電使用有以下限制：When the stroke is 50mm, the sensor installation has the following restrictions:

1. 原點與極限需放置於不同側。2. 滑座左右兩側皆需安裝感應片。Motor Direction BC/BM 1.Home sensor and limit sensor has to be installed on the different side of body. 2.Both sides of slider need to install the sensor trigger device.
1. 原點+極限感應器最數量最多2只 (僅能選用C3/D3/E3/E4/E5)。Motor Direction BL/BR 1.Home + limit sensors is 2 maximum (only C3/D3/E3/E4/E5 can be selected)

基本仕様 Specification

性能	位置重複精度 Repeatability	mm	±0.06	
	導程 Lead	mm	60	
	最高轉速 Maximum Rotating speed	rpm	2000	
	最高速度 Maximum linear speed	mm/s	2000	
	最大可搬重量 Maximum Payload	水平使用 Horizontal	kg	8
		垂直使用 Vertical	kg	
	定格推力 Rated Thrust	N	116	
	標準行程 Stroke (increments)	mm	50-3000mm / 50 間隔 (50 increments)	
	最大加速度 Maximum acceleration	G	0.51	
部品	AC 伺服馬達容量 AC Servo Motor Output	W	400	
	皮帶寬度 Belt Width	mm	8	
	原點感應器 Home Sensor	外掛 Outside	T64N2 (NPN+2 米線) (NPN+2M Cable)	

容許負載力距表 Allowable Overhang

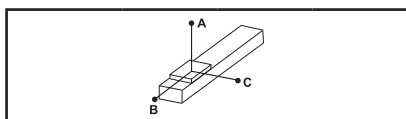

(單位 Unit: mm)

水平安裝 Horizontal Installation	A	B	C
2kg	1110	126	132
5kg	427	90	94
8kg	256	73	77

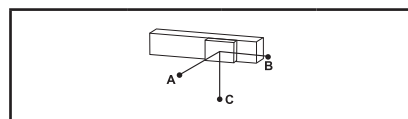

(單位 Unit: mm)

壁掛安裝 Wall Installation	A	B	C
2kg	132	126	1110
5kg	94	90	427
8kg	77	73	256

靜額定扭矩 Static Loading Moment

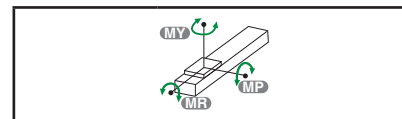

(單位 Unit: N.m)

MY	137
MP	137
MR	227

* 力矩表所表示的數據，代表荷重的重心位置於單一方向容許懸出的長度。
The data represented by the moment table is the center of gravity of the load. The length of the overhang is allowed in a single direction.

* 符合型錄規範的正常使用下，保證壽命為 10000 公里。
Operation life is 10,000km when the product is using under the specified conditions.

* 倒吊使用無法套用標準規範，如有需求請洽詢我司業務。
Data information is not for ceiling-mount inverse use. Contact us for the details if you want to apply ceiling-mount inverse usage.

* 壽命及力矩是以馬達加速減速設定 0.4 秒計算。
The life and torque are calculated by setting the motor acceleration and deceleration for 0.4 seconds.

選配 Options

MM

指定馬達出線方向 Selectable Cable Leading Direction		
代號 Code	說明 Instructions	需參照 Refer to
MW	朝上 Upper side	P.111 ~ P.112
MM	朝下 Bottom side	
ML	朝左 Left side	
MR	朝右 Right side	

CMK

馬達傳動配件追加鍵槽 Additional keyway for motor drive parts			
代號 Code	說明 Instructions		需參照 Refer to
	追加鍵槽 Keyway Groove	出貨型式 Shipment Type	
CMK	單邊 (限定馬達側) Single (Limited to the motor side)	鍵槽式皮帶輪 Keyway Belt Pulley	P.113 ~ P.115



Download at www.toyorobot.com

BW 馬達上折 Motor Top Side

單位 Unit : mm

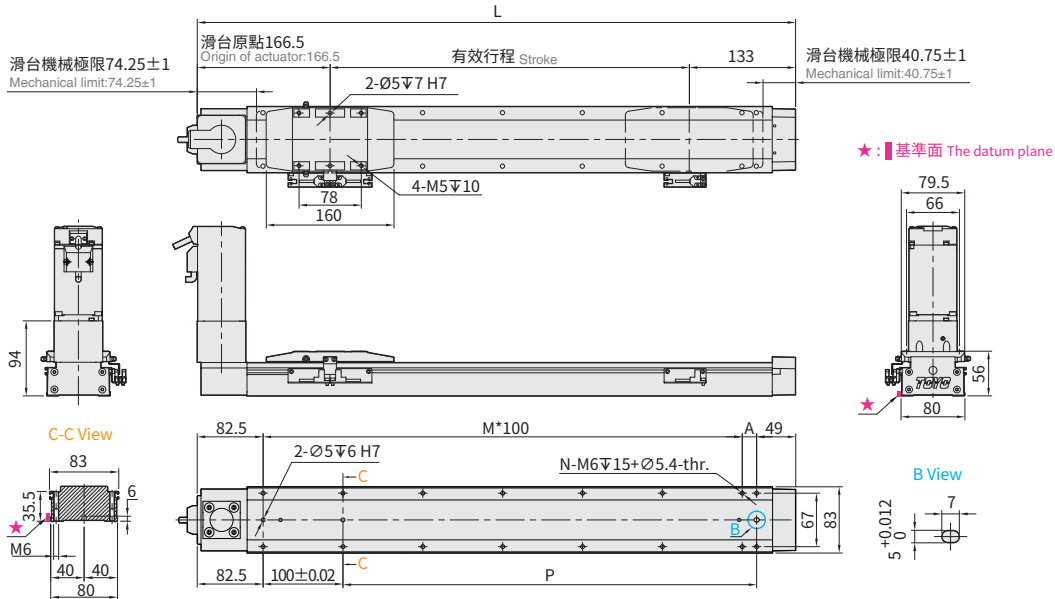

BM 馬達下折 Motor Bottom Side

單位 Unit : mm

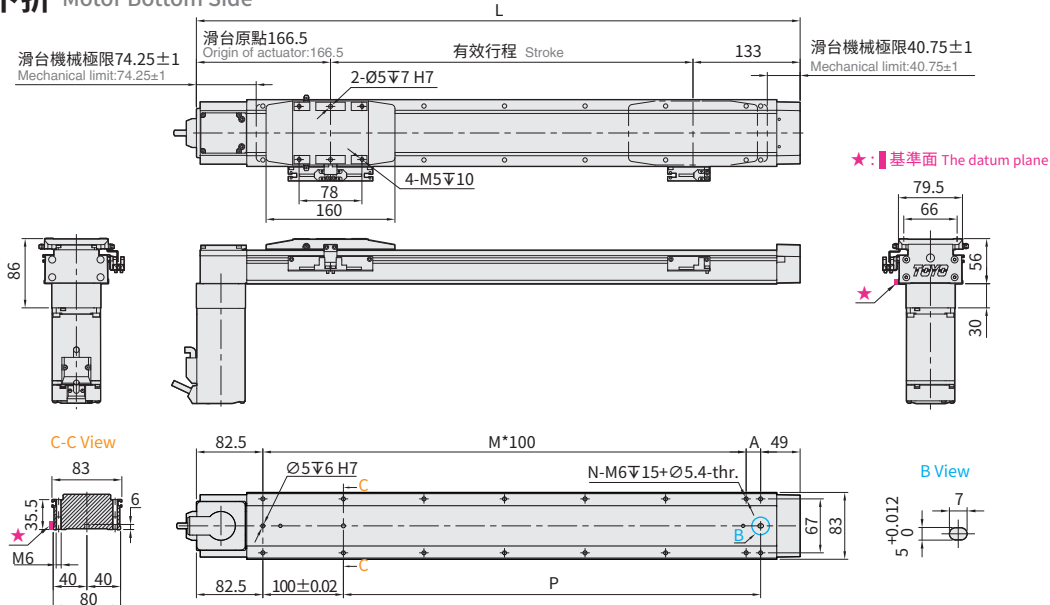

有效行程 Stroke	50	100	150	200	250	300	350	400	450	500	550	600	650	700	750	800	850	900	950	1000	1050	1100	1150	1200	1250	1300	1350	1400	1450	1500		
極限行程 Limit Stroke (±1)	74.5	124.5	174.5	224.5	274.5	324.5	374.5	424.5	474.5	524.5	574.5	624.5	674.5	724.5	774.5	824.5	874.5	924.5	974.5	1024.5	1074.5	1124.5	1174.5	1224.5	1274.5	1324.5	1374.5	1424.5	1474.5	1524.5		
L	349.5	399.5	449.5	499.5	549.5	599.5	649.5	699.5	749.5	799.5	849.5	899.5	949.5	999.5	1049.5	1099.5	1149.5	1199.5	1249.5	1299.5	1349.5	1399.5	1449.5	1499.5	1549.5	1599.5	1649.5	1699.5	1749.5	1799.5		
A	18	68	18	68	18	68	18	68	18	68	18	68	18	68	18	68	18	68	18	68	18	68	18	68	18	68	18	68	18	68		
M	2	2	3	3	4	4	5	5	6	6	7	7	8	8	9	9	10	10	11	11	12	12	13	13	14	14	15	15	16	16		
N	8	8	10	10	12	12	14	14	16	16	18	18	20	20	22	22	24	24	26	26	28	28	30	30	32	32	34	34	36	36		
P	118	168	218	268	318	368	418	468	518	568	618	668	718	768	818	868	918	968	1018	1068	1118	1168	1218	1268	1318	1368	1418	1468	1518	1568		
KG	2.52	2.73	2.94	3.15	3.36	3.57	3.78	3.99	4.2	4.41	4.62	4.83	5.04	5.25	5.46	5.67	5.88	6.09	6.3	6.51	6.72	6.93	7.14	7.35	7.56	7.77	7.98	8.19	8.4	8.61		
線速度 Linear Speed mm/s	2000																															
有效行程 Stroke	1550	1600	1650	1700	1750	1800	1850	1900	1950	2000	2050	2100	2150	2200	2250	2300	2350	2400	2450	2500	2550	2600	2650	2700	2750	2800	2850	2900	2950	3000		
極限行程 Limit Stroke (±1)	1574.5	1624.5	1674.5	1724.5	1774.5	1824.5	1874.5	1924.5	1974.5	2024.5	2074.5	2124.5	2174.5	2224.5	2274.5	2324.5	2374.5	2424.5	2474.5	2524.5	2574.5	2624.5	2674.5	2724.5	2774.5	2824.5	2874.5	2924.5	2974.5	3024.5		
L	1849.5	1899.5	1949.5	1999.5	2049.5	2099.5	2149.5	2199.5	2249.5	2299.5	2349.5	2399.5	2449.5	2499.5	2549.5	2599.5	2649.5	2699.5	2749.5	2799.5	2849.5	2899.5	2949.5	2999.5	3049.5	3099.5	3149.5	3199.5	3249.5	3299.5		
A	18	68	18	68	18	68	18	68	18	68	18	68	18	68	18	68	18	68	18	68	18	68	18	68	18	68	18	68	18	68		
M	17	17	18	18	19	19	20	20	21	21	22	22	23	23	24	24	25	25	26	26	27	27	28	28	29	29	30	30	31	31		
N	38	38	40	40	42	42	44	44	46	46	48	48	50	50	52	52	54	54	56	56	58	58	60	60	62	62	64	64	66	66		
P	1618	1668	1718	1768	1818	1868	1918	1968	2018	2068	2118	2168	2218	2268	2318	2368	2418	2468	2518	2568	2618	2668	2718	2768	2818	2868	2918	2968	3018	3068		
KG	8.82	9.03	9.24	9.45	9.66	9.87	10.08	10.29	10.5	10.71	10.92	11.13	11.34	11.55	11.76	11.97	12.18	12.39	12.6	12.81	13.02	13.23	13.44	13.65	13.86	14.07	14.28	14.49	14.7	14.91		
線速度 Linear Speed mm/s	2000																															

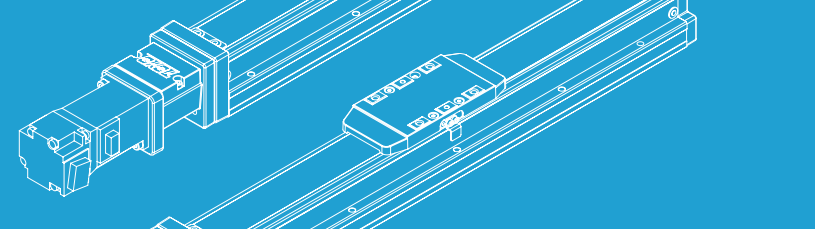

應用例
Application

一般 / 螺桿仕様
GTH / GTV / ETH / Y

一般 / 皮帶仕様
GLTB

無塵 / 螺桿仕様
GCH / ECH

無塵 / 皮帶仕様
ECB

直交連結
XYGT / XTH / XYTB

參考資料
Reference

Memo

Large empty rectangular area for taking notes.

GLTB Series

GLTB5

GLTB8

精度
±0.005 mm

Clean Room

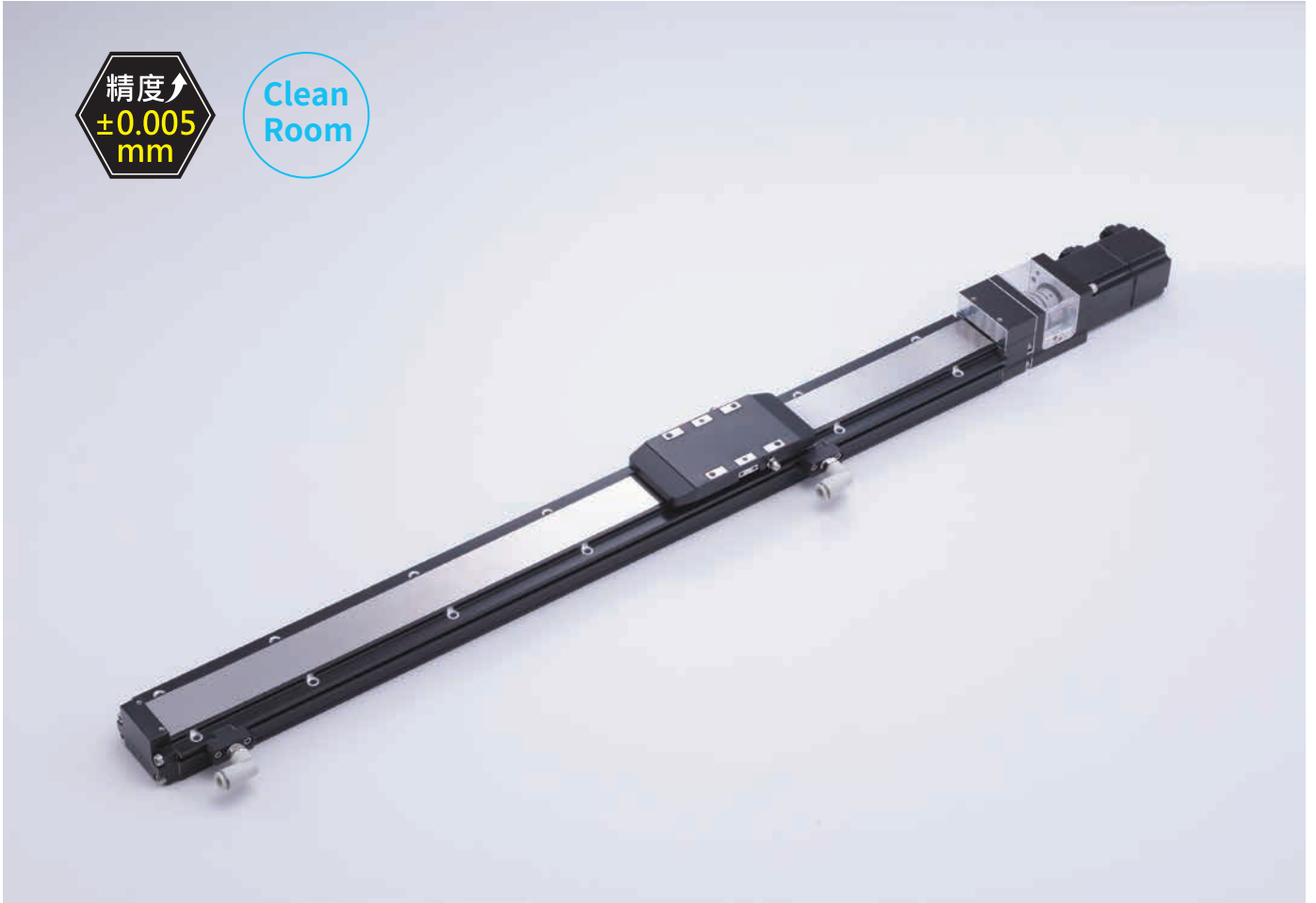

最大行程
Maximum Stroke **1000mm**

最高速度
Maximum Speed **1200mm/s**

馬達容量
Motor Output **100W**

最大可搬重量
Max Payload **30kg**

型號表示方式 Ordering Method

GLCH5 - L2 - 100 - BC - M10B - C4N5 - 參照右頁
Refer to the right page - 0001

本體型號
Model

行程^{*1}
Stroke

50-1000mm
50間隔 50 mm Pitch

選配
Options

特注式樣
Customization Order No.

螺桿導程
Ball Screw Lead

2	2mm
6	6mm
12	12mm
20	20mm

馬達位置
Motor Position

BC	馬達外露 Motor Exposed
BM	馬達下折 Motor Bottom Side
BL	馬達左折 Motor Left Side
BR	馬達右折 Motor Right Side

馬達廠牌、功率
Motor Brand · Power Output

M	三菱 Mitsubishi	05	-	B ^{*2}
P	松下 Panasonic	10	100W	
Y	安川 Yaskawa	20	-	
T	台達 Delta	40	-	

原點感應器
Home Sensor

外掛型 Out Side	
C	馬達側 Motor Side
D	反馬達側 Opposite Motor Side
無 SENSOR No Sensor	
E	無 SENSOR No Sensor

端點極限感應器
Limit Sensor

外掛型 Out Side	
3	1只 1 Pc
4	2只 2 Pcs
6	3只 3 Pcs
7	4只 4 Pcs
8	5只 5 Pcs
9	6只 6 Pcs
無 SENSOR No Sensor	
5	無 SENSOR No Sensor

輸出方式&線長
Output type & Cable length

N5	NPN+5米線 NPN+5M Cable
P2	PNP+2米線 PNP+2M Cable
P5	PNP+5米線 PNP+5M Cable
-	NPN+2米線 NPN+2M Cable

^{*1} 選擇行程50時，光電使用有以下限制：When the stroke is 50mm, the sensor installation has the following restrictions:

馬達方向 BC/BM：1.原點與極限需放置於不同側。2.滑座左右兩側皆需安裝感應片。1.Home sensor and limit sensor has to be installed on the different side of body, 2.Both sides of slider need to install the sensor trigger device.

馬達方向 BL/BR：1.原點+極限感應器最數量最多2只 (僅能選用C3/D3/E3/E4/E5)。1.Home + limit sensors is 2 maximum (only C3/D3/E3/E4/E5 can be selected)

^{*2} 若無煞車則不表示。If No Brake.No Description.

基本仕様 Specification

性能	位置重複精度 Repeatability	mm	±0.005				
	螺桿導程 Lead	mm	2	6	12	20	
	最高轉速 Maximum Rotating speed	rpm	3600	3600	3600	3600	
	最高速度 Maximum linear speed ^{※1}	mm/s	120	300	720	1200	
	最大可搬重量 ^{※2} Maximum Payload	水平使用 Horizontal	kg	30	25	22	10
		垂直使用 Vertical	kg	10	6	4	3
	定格推力 Rated Thrust	N	854	285	142	85	
	標準行程 Stroke (increments)	mm	50-1000mm / 50 間隔 (50 increments)				
	最大加速度 Maximum acceleration	G	0.12	0.37	0.73	1.22	
	滾珠螺桿 Ball screw	基本動額定負荷 Basic dynamic load rating Ca	N	2270	2243	1436	1384
基本靜額定負荷 Basic static load rating Coa		N	4836	3959	2441	2535	
直線滑軌 Linear Guide	動態水平負載 Dynamic horizontal (100km)	N	6563				
	靜態水平負載 Static Horizontal	N	13587				
固定側軸承 Fixed bearing	基本動額定負荷 Basic dynamic load rating Cr	N	5361				
	靜態容許負荷 Static load rating Cor	N	2880				
部品	AC 伺服馬達容量 AC Servo Motor Output	W	100				
	滾珠螺桿外徑 Ball Screw Ø	mm	C7Ø10				
	連軸器 Coupling	mm	7X8				
	原點感應器 Home Sensor	外掛 Outside	T64N2 (NPN+2 米線) (NPN+2M Cable)				

※1 長行程時，會產生螺桿偏擺，需將速度調降 (線速度請參閱尺寸圖下方表格)

During in a long stroke, it causes ballscrew deflection, the speed must reduce. (Please refer to the linear velocity from the data sheet below the dimension graph.)

※2 由於各廠牌的馬達性能不同，需適度搭配回升電阻以達到此荷重條件。

Since the motor performance of each brand is different, a regenerative resistor needs to be appropriately matched to achieve this load condition.

容許負載力距表 Allowable Overhang

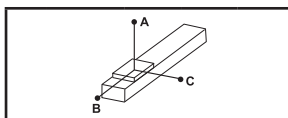

(單位 Unit: mm)

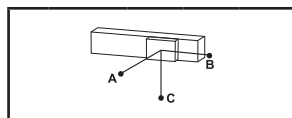

(單位 Unit: mm)

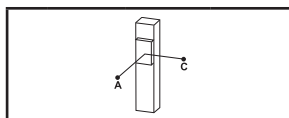

(單位 Unit: mm)

水平安裝 Horizontal Installation		A	B	C
導程 2 Lead	10kg	2500	157	250
	20kg	1120	70	112
	30kg	650	41	65
導程 6 Lead	10kg	1400	122	184
	20kg	650	52	79
	25kg	490	38	57
導程 12 Lead	8kg	590	132	175
	10kg	460	103	135
	22kg	185	37	49
導程 20 Lead	3kg	656	300	303
	6kg	314	141	144
	10kg	177	78	79

壁掛安裝 Wall Installation		A	B	C
導程 2 Lead	10kg	250	157	2500
	20kg	112	70	1120
	30kg	65	41	650
導程 6 Lead	10kg	184	122	1400
	20kg	79	52	650
	25kg	57	38	490
導程 12 Lead	8kg	175	132	590
	10kg	135	103	460
	22kg	49	37	185
導程 20 Lead	3kg	303	300	656
	6kg	144	141	314
	10kg	79	78	177

垂直安裝 Vertical Installation		A	C
導程 2 Lead	5kg	346	346
	10kg	173	173
	-	-	-
導程 6 Lead	3kg	463	463
	6kg	231	231
	-	-	-
導程 12 Lead	2.5kg	465	465
	4kg	292	292
	-	-	-
導程 20 Lead	1.5kg	555	555
	3g	278	278
	-	-	-

靜額定扭矩 Static Loading Moment

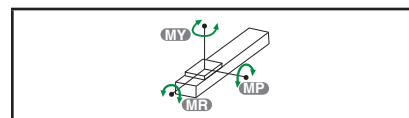

(單位 Unit: N.m)

MY	73
MP	73
MR	115

* 力矩表所表示的數據，代表荷重的重心位置於單方向容許懸出的長度。
The data represented by the moment table is the center of gravity of the load. The length of the overhang is allowed in a single direction.

* 符合型錄規範的正常使用下，保證壽命為 10000 公里。
Operation life is 10,000km when the product is using under the specified conditions.

* 倒吊使用無法套用標準規範，如有需求請洽詢我司業務。
Data information is not for ceiling-mount inverse use. Contact us for the details if you want to apply ceiling-mount inverse usage.

* 壽命及力矩是以馬達加減速設定 0.2 秒計算。
The life and torque are calculated by setting the motor acceleration and deceleration for 0.2 seconds.

選配 Options

MM

指定馬達出線方向 Selectable Cable Leading Direction		
代號 Code	說明 Instructions	需參照 Refer to
MW	朝上 Upper side	P.111 ~ P.112
MM	朝下 Bottom side	
ML	朝左 Left side	
MR	朝右 Right side	

CMK

馬達傳動配件追加鍵槽 Additional keyway for motor drive parts				
代號 Code	說明 Instructions			需參照 Refer to
	追加鍵槽 Keyway Groove	馬達位置 Motor Position	出貨型式 Shipment Type	
CMK	單邊 (限定馬達側) Single (Limited to the motor side)	BC	鍵槽式聯軸器 Keyway Coupling	P.113 ~ P.115
		BL/BR/BM	鍵槽式皮帶輪 Keyway Belt Pulley	
SKY	雙邊 Double	BC	鍵槽式聯軸器 Keyway Coupling	
		BL/BR/BM	鍵槽式皮帶輪 Keyway Belt Pulley	
SKN	雙邊 Double	BC	無聯軸器 (請自行購買安裝) Without Coupling (Please purchase and install by yourself)	
		BL/BR/BM	無馬達端皮帶輪 (請自行購買安裝) Without Belt Pulley (Please purchase and install by yourself)	



Download at www.toyorobot.com

BL 馬達左折 Motor Left Side

單位 Unit : mm

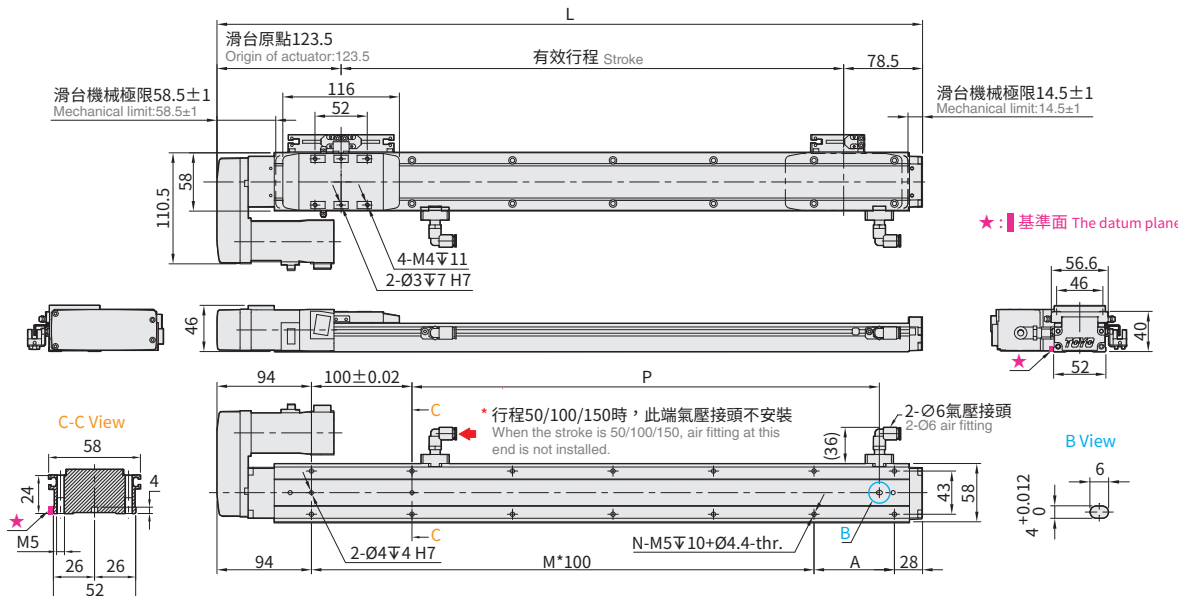

BR 馬達右折 Motor Right Side

單位 Unit : mm

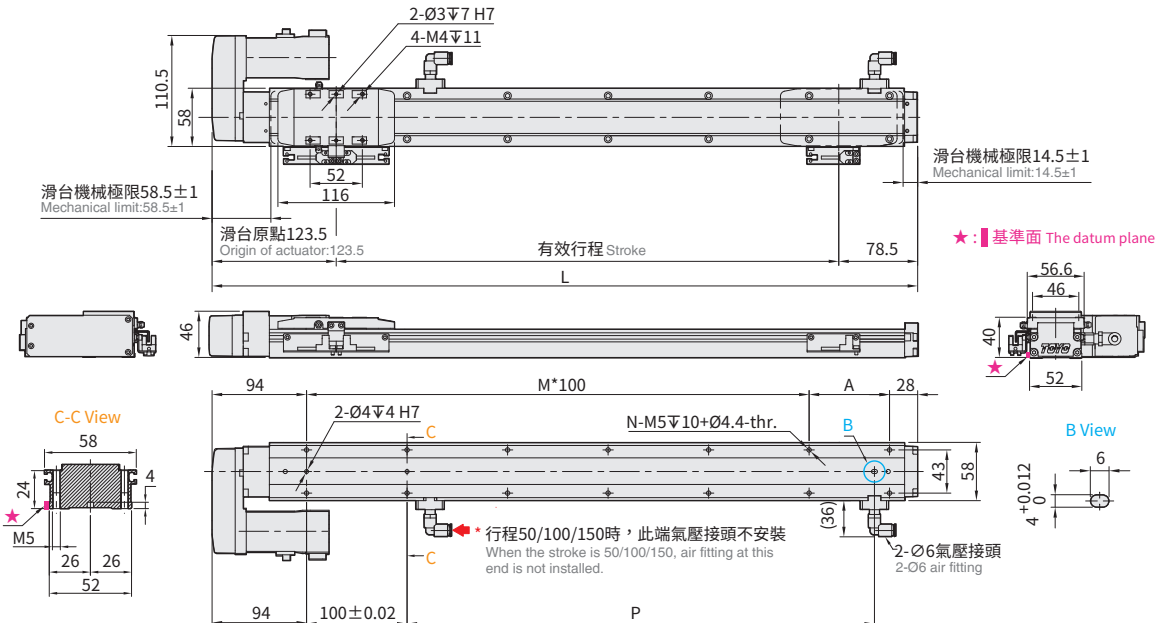

有效行程 Stroke	50 ⁻¹	100	150	200	250	300	350	400	450	500	550	600	650	700	750	800	850	900	950	1000		
極限行程 Limit Stroke (±1)	63	113	163	213	263	313	363	413	463	513	563	613	663	713	763	813	863	913	963	1013		
L	252	302	352	402	452	502	552	602	652	702	752	802	852	902	952	1002	1052	1102	1152	1202		
A	30	80	30	80	30	80	30	80	30	80	30	80	30	80	30	80	30	80	30	80		
M	1	1	2	2	3	3	4	4	5	5	6	6	7	7	8	8	9	9	10	10		
N	6	6	8	8	10	10	12	12	14	14	16	16	18	18	20	20	22	22	24	24		
P	15	65	115	165	215	265	315	365	415	465	515	565	615	665	715	765	815	865	915	965		
KG	1.2	1.33	1.46	1.58	1.71	1.83	1.96	2.09	2.21	2.34	2.47	2.59	2.72	2.85	2.97	3.1	3.22	3.35	3.48	3.6		
線速度 Linear Speed mm/s	導程 Lead 2											110	90	80	70	63	53	50	43	40	36	
	導程 Lead 6											330	270	240	210	190	160	150	130	120	110	
	導程 Lead 12											660	540	480	420	380	320	300	260	240	220	
	導程 Lead 20											1100	900	800	700	630	533	500	430	400	367	

※1 行程 50 時，因本體上鎖式固定孔會被滑座遮住，僅能使用 4 支螺絲固定，建議客戶本體使用下鎖式固定孔鎖附。When the stroke is 50mm, if fixing the body from the top to the bottom, the fixing hole will be blocked by slider and only can be uses 4 screws to fix, as a result, suggest that fixing actuator body from the bottom to the top.

應用例
Application

無塵 / 螺桿仕様
GLCH

一般 / 皮帶仕様
ETB / M

無塵 / 螺桿仕様
GCH / ECH

無塵 / 皮帶仕様
ECB

直交連結
XYGT / XYTH / XYTB

參考資料
Reference

GLCH Series

GLCH5

GLCH8

GLCH12

GLCH5D

GLCH8D

精度
±0.005 mm

Clean Room



最大行程
Maximum Stroke 1250mm

最高速度
Maximum Speed 1440mm/s

馬達容量
Motor Output 200W

最大可搬重量
Max Payload 80kg

型號表示方式 Ordering Method

GLCH8 - L6 - 100 - BC - M20B - C4N5 - 參照右頁
Refer to the right page - 0001

本體型號
Model

行程^{*1}
Stroke

50-1250mm
50mm間隔 50 mm Pitch

選配
Options

特注式樣
Customization Order No.

螺桿導程
Ball Screw Lead

6	6mm
12	12mm
24	24mm

馬達位置
Motor Position

BC	馬達外露 Motor Exposed
BM	馬達下折 Motor Bottom Side
BL	馬達左折 Motor Left Side
BR	馬達右折 Motor Right Side

馬達廠牌、功率
Motor Brand · Power Output

M	三菱 Mitsubishi	05	-	B ^{*2}
P	松下 Panasonic	10	-	
Y	安川 Yaskawa	20	200W	
T	台達 Delta	40	-	

原點感應器
Home Sensor

外掛型 Out Side	
C	馬達側 Motor Side
D	反馬達側 Opposite Motor Side
無 SENSOR No Sensor	
E	無 SENSOR No Sensor

端點極限感應器
Limit Sensor

外掛型 Out Side	
3	1只 1 Pc
4	2只 2 Pcs
6	3只 3 Pcs
7	4只 4 Pcs
8	5只 5 Pcs
9	6只 6 Pcs
無 SENSOR No Sensor	
5	無 SENSOR No Sensor

輸出方式&線長
Output type & Cable length

N5	NPN+5米線 NPN+5M Cable
P2	PNP+2米線 PNP+2M Cable
P5	PNP+5米線 PNP+5M Cable
-	NPN+2米線 NPN+2M Cable

^{*1} 選擇行程50時，光電使用有以下限制：When the stroke is 50mm, the sensor installation has the following restrictions:

馬達方向 BC/BM：1.原點與極限需放置於不同側。2.滑座左右兩側皆需安裝感應片。Motor Direction BC/BM 1.Home sensor and limit sensor has to be installed on the different side of body. 2.Both sides of slider need to install the sensor trigger device.

馬達方向 BL/BR：1.原點+極限感應器最數量最多2只(僅能選用C3/D3/E3/E4/E5)。Motor Direction BL/BR 1.Home + limit sensors is 2 maximum (only C3/D3/E3/E4/E5 can be selected)

^{*2} 馬達若無煞車則不表示。If Motor No Brake, No Description.

基本仕様 Specification

性能	位置重複精度 Repeatability	mm	±0.005			
	螺桿導程 Lead	mm	6	12	24	
	最高轉速 Maximum Rotating speed	rpm	3600	3600	3600	
	最高速度 Maximum linear speed ※1	mm/s	360	720	1440	
	最大可搬重量 ※2 Maximum Payload	水平使用 Horizontal	kg	80	60	40
		垂直使用 Vertical	kg	15	8	5
	定格推力 Rated Thrust	N	569	284	142	
	標準行程 Stroke (increments)	mm	50-1250mm / 50 間隔 (50 increments)			
	最大加速度 Maximum acceleration	G	0.37	0.73	1.47	
	滾珠螺桿 Ball screw	基本動額定負荷 Basic dynamic load rating Ca	N	7733	5855	3007
基本靜額定負荷 Basic static load rating Coa		N	14200	10401	5414	
直線滑軌 Linear Guide	動態水平負載 Dynamic horizontal (100km)	N	18601			
	靜態水平負載 Static Horizontal	N	34189			
固定側軸承 Fixed bearing	基本動額定負荷 Basic dynamic load rating Cr	N	8447			
	靜態容許負荷 Static load rating Cor	N	5060			
部品	AC 伺服馬達容量 AC Servo Motor Output	W	200			
	滾珠螺桿外徑 Ball Screw Ø	mm	C7Ø14			
	連軸器 Coupling	mm	10X14 /11 ※3			
	原點感應器 Home Sensor	外掛 Outside	T64N2 (NPN+2 米線) (NPN+2M Cable)			

※1 長行程時，會產生螺桿偏擺，需將速度調降 (線速度請參閱尺寸圖下方表格)
During in a long stroke, it causes ballscrew deflection, the speed must reduce. (Please refer to the linear velocity from the data sheet below the dimension graph.)
 ※2 由於各廠牌的馬達性能不同，需適度搭配回升電阻以達到此荷重條件。
Since the motor performance of each brand is different, a regenerative resistor needs to be appropriately matched to achieve this load condition.
 ※3 使用 Panasonic 200W 馬達時，馬達軸心為 Ø11；其他廠牌，馬達軸心為 Ø14。Motor (200W) Shaft Diameter: Panasonic: 11mm; Other: 14mm.

容許負載力距表 Allowable Overhang

(單位 Unit : mm)	(單位 Unit : mm)	(單位 Unit : mm)																																																																																																																																		
<table border="1"> <tr><th colspan="4">水平安裝 Horizontal Installation</th></tr> <tr><th>導程 Lead</th><th>A</th><th>B</th><th>C</th></tr> <tr><td rowspan="3">6</td><td>35kg</td><td>1600</td><td>139</td><td>220</td></tr> <tr><td>45kg</td><td>1210</td><td>102</td><td>160</td></tr> <tr><td>80kg</td><td>620</td><td>46</td><td>74</td></tr> <tr><td rowspan="3">12</td><td>10kg</td><td>2040</td><td>470</td><td>645</td></tr> <tr><td>30kg</td><td>638</td><td>141</td><td>193</td></tr> <tr><td>60kg</td><td>283</td><td>58</td><td>80</td></tr> <tr><td rowspan="3">24</td><td>20kg</td><td>253</td><td>145</td><td>133</td></tr> <tr><td>40kg</td><td>109</td><td>60</td><td>55</td></tr> <tr><td>-</td><td>-</td><td>-</td><td>-</td></tr> </table>	水平安裝 Horizontal Installation				導程 Lead	A	B	C	6	35kg	1600	139	220	45kg	1210	102	160	80kg	620	46	74	12	10kg	2040	470	645	30kg	638	141	193	60kg	283	58	80	24	20kg	253	145	133	40kg	109	60	55	-	-	-	-	<table border="1"> <tr><th colspan="4">壁掛安裝 Wall Installation</th></tr> <tr><th>導程 Lead</th><th>A</th><th>B</th><th>C</th></tr> <tr><td rowspan="3">6</td><td>35kg</td><td>220</td><td>139</td><td>1600</td></tr> <tr><td>45kg</td><td>160</td><td>102</td><td>1210</td></tr> <tr><td>80kg</td><td>74</td><td>46</td><td>620</td></tr> <tr><td rowspan="3">12</td><td>10kg</td><td>645</td><td>470</td><td>2040</td></tr> <tr><td>30kg</td><td>193</td><td>141</td><td>638</td></tr> <tr><td>60kg</td><td>80</td><td>58</td><td>283</td></tr> <tr><td rowspan="3">24</td><td>20kg</td><td>133</td><td>145</td><td>253</td></tr> <tr><td>40kg</td><td>55</td><td>60</td><td>109</td></tr> <tr><td>-</td><td>-</td><td>-</td><td>-</td></tr> </table>	壁掛安裝 Wall Installation				導程 Lead	A	B	C	6	35kg	220	139	1600	45kg	160	102	1210	80kg	74	46	620	12	10kg	645	470	2040	30kg	193	141	638	60kg	80	58	283	24	20kg	133	145	253	40kg	55	60	109	-	-	-	-	<table border="1"> <tr><th colspan="3">垂直安裝 Vertical Installation</th></tr> <tr><th>導程 Lead</th><th>A</th><th>C</th></tr> <tr><td rowspan="3">6</td><td>10kg</td><td>535</td><td>535</td></tr> <tr><td>15kg</td><td>360</td><td>360</td></tr> <tr><td>-</td><td>-</td><td>-</td></tr> <tr><td rowspan="3">12</td><td>3.5kg</td><td>1380</td><td>1380</td></tr> <tr><td>8kg</td><td>605</td><td>605</td></tr> <tr><td>-</td><td>-</td><td>-</td></tr> <tr><td rowspan="3">24</td><td>2kg</td><td>1380</td><td>1380</td></tr> <tr><td>5kg</td><td>556</td><td>556</td></tr> <tr><td>-</td><td>-</td><td>-</td></tr> </table>	垂直安裝 Vertical Installation			導程 Lead	A	C	6	10kg	535	535	15kg	360	360	-	-	-	12	3.5kg	1380	1380	8kg	605	605	-	-	-	24	2kg	1380	1380	5kg	556	556	-	-	-
水平安裝 Horizontal Installation																																																																																																																																				
導程 Lead	A	B	C																																																																																																																																	
6	35kg	1600	139	220																																																																																																																																
	45kg	1210	102	160																																																																																																																																
	80kg	620	46	74																																																																																																																																
12	10kg	2040	470	645																																																																																																																																
	30kg	638	141	193																																																																																																																																
	60kg	283	58	80																																																																																																																																
24	20kg	253	145	133																																																																																																																																
	40kg	109	60	55																																																																																																																																
	-	-	-	-																																																																																																																																
壁掛安裝 Wall Installation																																																																																																																																				
導程 Lead	A	B	C																																																																																																																																	
6	35kg	220	139	1600																																																																																																																																
	45kg	160	102	1210																																																																																																																																
	80kg	74	46	620																																																																																																																																
12	10kg	645	470	2040																																																																																																																																
	30kg	193	141	638																																																																																																																																
	60kg	80	58	283																																																																																																																																
24	20kg	133	145	253																																																																																																																																
	40kg	55	60	109																																																																																																																																
	-	-	-	-																																																																																																																																
垂直安裝 Vertical Installation																																																																																																																																				
導程 Lead	A	C																																																																																																																																		
6	10kg	535	535																																																																																																																																	
	15kg	360	360																																																																																																																																	
	-	-	-																																																																																																																																	
12	3.5kg	1380	1380																																																																																																																																	
	8kg	605	605																																																																																																																																	
	-	-	-																																																																																																																																	
24	2kg	1380	1380																																																																																																																																	
	5kg	556	556																																																																																																																																	
	-	-	-																																																																																																																																	

靜額定扭矩 Static Loading Moment

	(單位 Unit : N.m)
MY	137
MP	137
MR	227

* 力矩表所表示的數據，代表荷重的重心位置於單一方向容許懸出的長度。
The data represented by the moment table is the center of gravity of the load. The length of the overhang is allowed in a single direction.
 * 符合型錄規範的正常使用下，保證壽命為 10000 公里。
Operation life is 10,000km when the product is using under the specified conditions.
 * 倒吊使用無法套用標準規範，如有需求請洽詢我司業務。
Data information is not for ceiling-mount inverse use. Contact us for the details if you want to apply ceiling-mount inverse usage.
 * 壽命及力矩是以馬達加減速設定 0.2 秒計算。
The life and torque are calculated by setting the motor acceleration and deceleration for 0.2 seconds.

選配 Options

MM

指定馬達出線方向 Selectable Cable Leading Direction		
代號 Code	說明 Instructions	需參照 Refer to
MW	朝上 Upper side	P.111 ~ P.112
MM	朝下 Bottom side	
ML	朝左 Left side	
MR	朝右 Right side	

CMK

馬達傳動配件追加鍵槽 Additional keyway for motor drive parts				
代號 Code	說明 Instructions			需參照 Refer to
	追加鍵槽 Keyway Groove	馬達位置 Motor Position	出貨型式 Shipment Type	
CMK	單邊 (限定馬達側) Single (Limited to the motor side)	BC	鍵槽式聯軸器 Keyway Coupling	P.113 ~ P.115
		BL/BR/BM	鍵槽式皮帶輪 Keyway Belt Pulley	
SKY	雙邊 Double	BC	鍵槽式聯軸器 Keyway Coupling	
		BL/BR/BM	鍵槽式皮帶輪 Keyway Belt Pulley	
SKN	雙邊 Double	BC	無聯軸器 (請自行購買安裝) Without Coupling (Please purchase and install by yourself)	
		BL/BR/BM	無馬達端皮帶輪 (請自行購買安裝) Without Belt Pulley (Please purchase and install by yourself)	



Download at www.toyorobot.com

BC 馬達外露 Motor Exposed

單位 Unit : mm

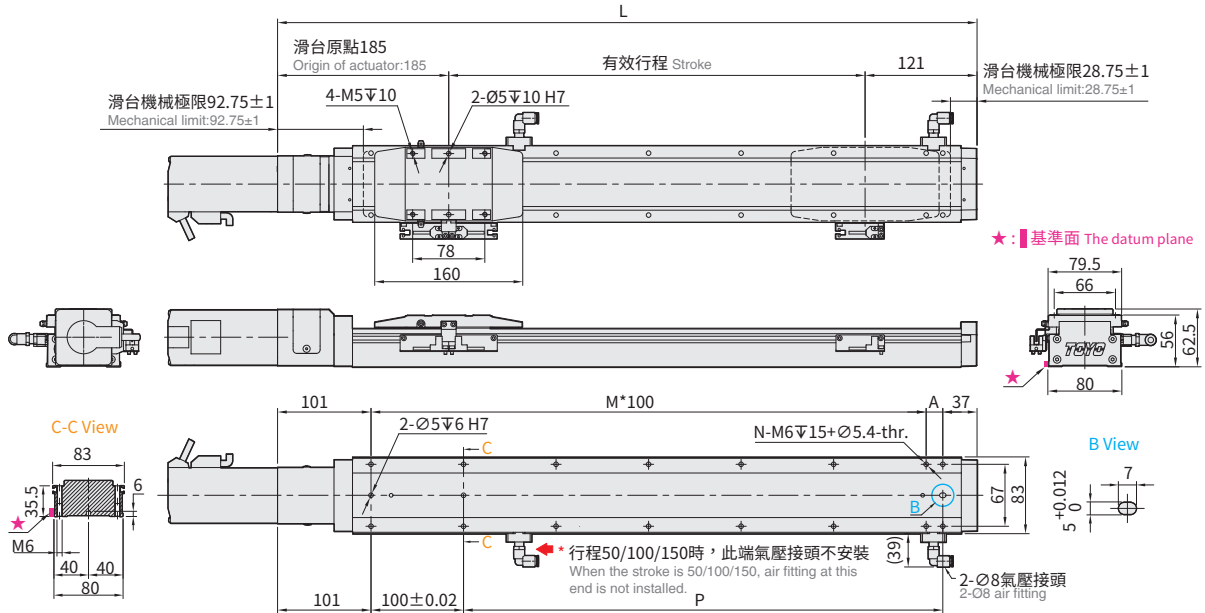

BM 馬達下折 Motor Bottom Side

單位 Unit : mm

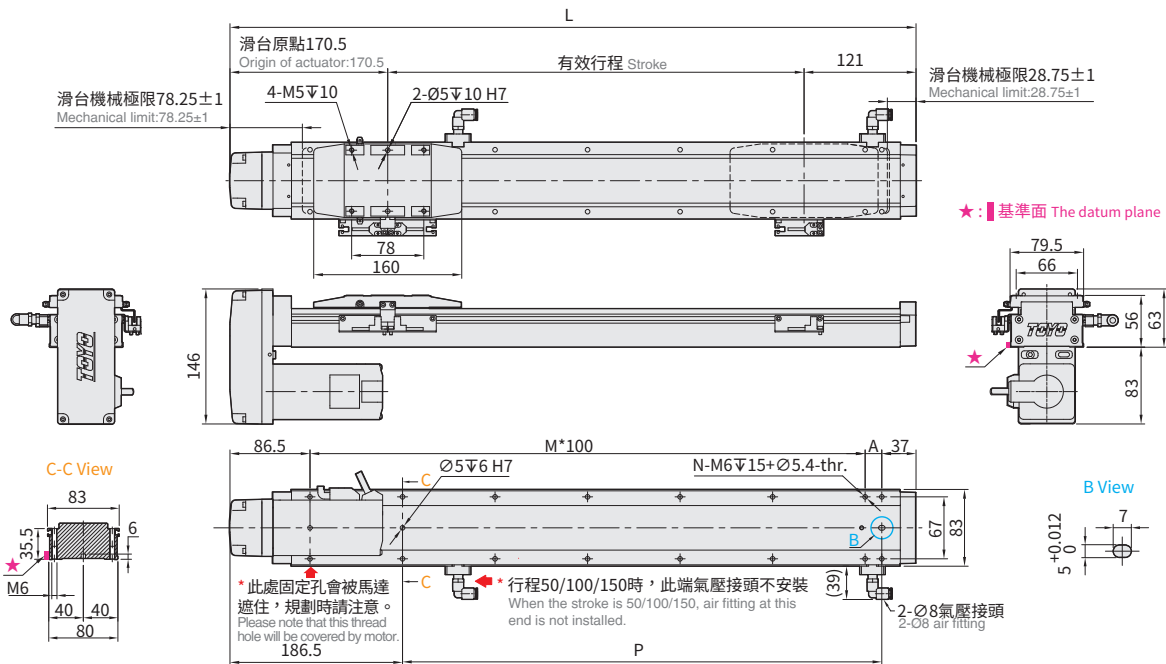

有效行程 Stroke	50 ⁻¹	100	150	200	250	300	350	400	450	500	550	600	650	700	750	800	850	900	950	1000	1050	1100	1150	1200	1250	
極限行程 Limit Stroke (±1)	74.5	124.5	174.5	224.5	274.5	324.5	374.5	424.5	474.5	524.5	574.5	624.5	674.5	724.5	774.5	824.5	874.5	924.5	974.5	1024.5	1074.5	1124.5	1174.5	1224.5	1274.5	
L	BC	356	406	456	506	556	606	656	706	756	806	856	906	956	1006	1056	1106	1156	1206	1256	1306	1356	1406	1456	1506	1556
	BM	341.5	391.5	441.5	491.5	541.5	591.5	641.5	691.5	741.5	791.5	841.5	891.5	941.5	991.5	1041.5	1091.5	1141.5	1191.5	1241.5	1291.5	1341.5	1391.5	1441.5	1491.5	1541.5
A	18	68	118	168	218	268	318	368	418	468	518	568	618	668	718	768	818	868	918	968	1018	1068	1118	1168	1218	1268
M	2	2	3	3	4	4	5	5	6	6	7	7	8	8	9	9	10	10	11	11	12	12	13	13	14	
N	8	8	10	10	12	12	14	14	16	16	18	18	20	20	22	22	24	24	26	26	28	28	30	30	32	
P	118	168	218	268	318	368	418	468	518	568	618	668	718	768	818	868	918	968	1018	1068	1118	1168	1218	1268	1318	
KG	BC	2.35	2.65	2.94	3.24	3.53	3.83	4.13	4.42	4.72	5.01	5.31	5.61	5.91	6.2	6.5	6.79	7.09	7.39	7.68	7.98	8.28	8.57	8.87	9.17	9.46
	BM	2.72	3.02	3.31	3.61	3.91	4.2	4.5	4.79	5.09	5.39	5.68	5.98	6.28	6.57	6.87	7.17	7.46	7.76	8.05	8.35	8.65	8.94	9.24	9.54	9.83
線速度 Linear Speed mm/s	導程 Lead 6											350	310	270	240	210	190	170	160	140	130	120	110	100	90	
	導程 Lead 12											700	620	540	480	420	380	340	320	280	260	240	220	200	180	
	導程 Lead 24											1400	1240	1080	960	840	760	680	640	560	520	480	440	400	360	

* 1 行程 50 時，因本體上鎖式固定孔會被滑座遮住，僅能使用 4 支螺絲固定，建議客戶本體使用下鎖式固定鎖附。When the stroke is 50mm, if fixing the body from the top to the bottom, the fixing hole will be blocked by slider and only can be uses 4 screws to fix; as a result, suggest that fixing actuator body from the bottom to the top.



Download at www.toyorobot.com

BL 馬達左折 Motor Left Side

單位 Unit : mm

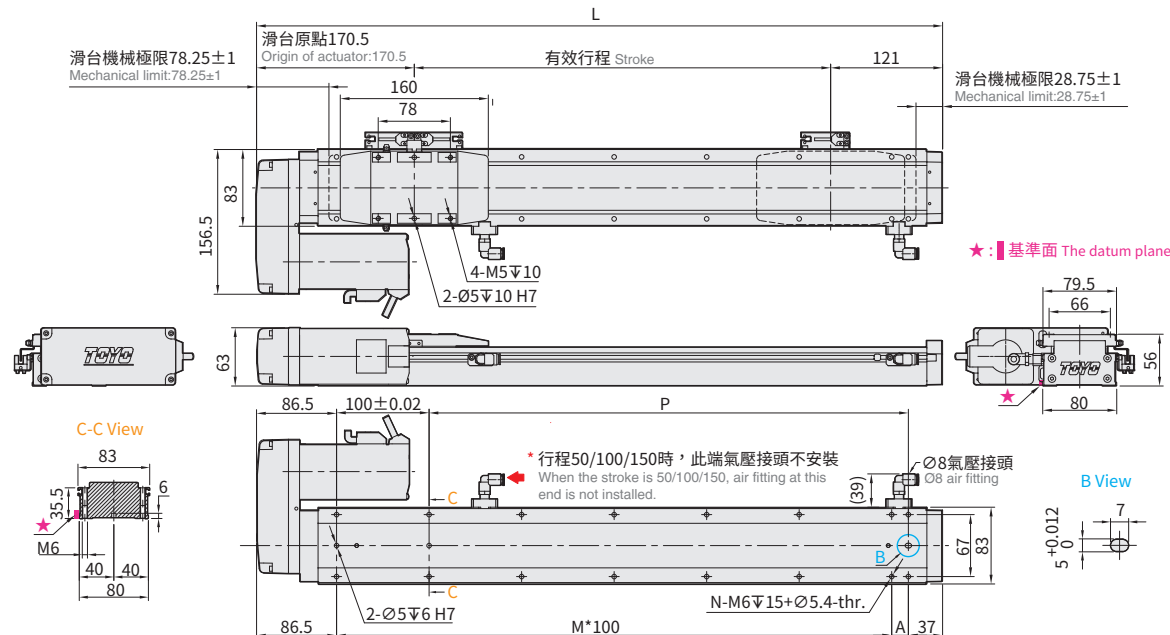

BR 馬達右折 Motor Right Side

單位 Unit : mm

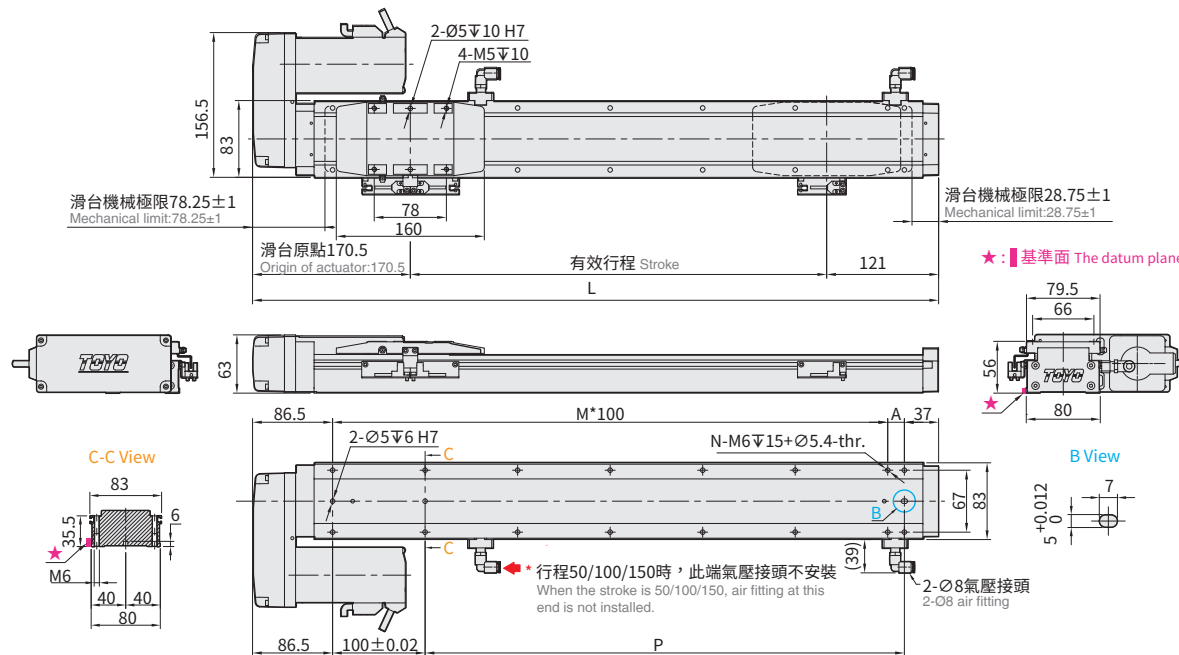

有效行程 Stroke	50 ⁻¹	100	150	200	250	300	350	400	450	500	550	600	650	700	750	800	850	900	950	1000	1050	1100	1150	1200	1250
極限行程 Limit Stroke (±1)	74.5	124.5	174.5	224.5	274.5	324.5	374.5	424.5	474.5	524.5	574.5	624.5	674.5	724.5	774.5	824.5	874.5	924.5	974.5	1024.5	1074.5	1124.5	1174.5	1224.5	1274.5
L	341.5	391.5	441.5	491.5	541.5	591.5	641.5	691.5	741.5	791.5	841.5	891.5	941.5	991.5	1041.5	1091.5	1141.5	1191.5	1241.5	1291.5	1341.5	1391.5	1441.5	1491.5	1541.5
A	18	68	18	68	18	68	18	68	18	68	18	68	18	68	18	68	18	68	18	68	18	68	18	68	18
M	2	2	3	3	4	4	5	5	6	6	7	8	8	9	9	10	10	11	11	12	12	13	13	14	14
N	8	8	10	10	12	12	14	14	16	16	18	18	20	20	22	22	24	24	26	26	28	28	30	30	32
P	118	168	218	268	318	368	418	468	518	568	618	668	718	768	818	868	918	968	1018	1068	1118	1168	1218	1268	1318
KG	2.72	3.02	3.31	3.61	3.91	4.2	4.5	4.79	5.09	5.39	5.68	5.98	6.28	6.57	6.87	7.17	7.46	7.76	8.05	8.35	8.65	8.94	9.24	9.54	9.83
線速度 Linear Speed mm/s	導程 Lead 6	360										350	310	270	240	210	190	170	160	140	130	120	110	100	90
	導程 Lead 12	720										700	620	540	480	420	380	340	320	280	260	240	220	200	180
	導程 Lead 24	1440										1400	1240	1080	960	840	760	680	640	560	520	480	440	400	360

※1 行程 50 時，因本體上鎖式固定孔會被滑座遮住，僅能使用 4 支螺絲固定，建議客戶本體使用下鎖式固定孔鎖附。When the stroke is 50mm, if fixing the body from the top to the bottom, the fixing hole will be blocked by slider and only can be uses 4 screws to fix; as a result, suggest that fixing actuator body from the bottom to the top.

應用例
Application

無塵 / 螺桿仕様
GLCH

一般 / 皮帶仕様
ETB / M

無塵 / 螺桿仕様
GCH / ECH

無塵 / 皮帶仕様
ECB

直交連結
XYGT / XYTH / XYTB

參考資料
Reference

GLCH Series

GLCH5

GLCH8

GLCH12

GLCH5D

GLCH8D

GLCH8 單軸 / 1-axis

▶ 軌道內嵌
Integrated Linear Bearing

▶ 螺桿驅動
Ball Screw Drive

精度
±0.005 mm

Clean Room



最大行程
Maximum Stroke 1250mm

最高速度
Maximum Speed 1440mm/s

馬達容量
Motor Output 400W

最大可搬重量
Max Payload 105kg

型號表示方式 Ordering Method

GLCH8 - L6 - 100 - BC - M40B - C4N5 - 參照右頁
Refer to the right page - 0001

本體型號
Model

行程^{*1}
Stroke

50-1250mm
50mm 間隔 50 mm Pitch

選配
Options

特注式樣
Customization Order No.

馬達位置
Motor Position

BC	馬達外露 Motor Exposed
BM	馬達下折 Motor Bottom Side
BL	馬達左折 Motor Left Side
BR	馬達右折 Motor Right Side

馬達廠牌、功率
Motor Brand · Power Output

M	三菱 Mitsubishi	05	-	B ^{*2}
P	松下 Panasonic	10	-	
Y	安川 Yaskawa	20	-	
T	台達 Delta	40	400W	

原點感應器
Home Sensor

外掛型 Out Side	
C	馬達側 Motor Side
D	反馬達側 Opposite Motor Side
無 SENSOR No Sensor	
E	無 SENSOR No Sensor

端點極限感應器
Limit Sensor

外掛型 Out Side	
3	1只 1 Pc
4	2只 2 Pcs
6	3只 3 Pcs
7	4只 4 Pcs
8	5只 5 Pcs
9	6只 6 Pcs
無 SENSOR No Sensor	
5	無 SENSOR No Sensor

輸出方式&線長
Output type & Cable length

N5	NPN+5米線 NPN+5M Cable
P2	PNP+2米線 PNP+2M Cable
P5	PNP+5米線 PNP+5M Cable
-	NPN+2米線 NPN+2M Cable

螺桿導程
Ball Screw Lead

6	6mm
12	12mm
24	24mm

*1 選擇行程50時，光電使用有以下限制：When the stroke is 50mm, the sensor installation has the following restrictions:

馬達方向 BC/BM：1.原點與極限需放置於不同側。2.滑座左右兩側皆需安裝感應片。Motor Direction BC/BM 1.Home sensor and limit sensor has to be installed on the different side of body. 2.Both sides of slider need to install the sensor trigger device.

馬達方向 BL/BR：1.原點+極限感應器最數量最多2只(僅能選用C3/D3/E3/E4/E5)。Motor Direction BL/BR 1.Home + limit sensors is 2 maximum (only C3/D3/E3/E4/E5 can be selected)

*2 馬達若無煞車則不表示。If Motor No Brake, No Description.

基本仕様 Specification

性能	位置重複精度 Repeatability	mm	±0.005			
	螺桿導程 Lead	mm	6	12	24	
	最高轉速 Maximum Rotating speed	rpm	3600	3600	3600	
	最高速度 Maximum linear speed ※1	mm/s	360	720	1440	
	最大可搬重量 Maximum Payload	水平使用 Horizontal	kg	105	85	40
		垂直使用 Vertical	kg	30	20	10
	定格推力 Rated Thrust	N	1156	578	289	
	標準行程 Stroke (increments)	mm	50-1250mm / 50 間隔 (50 increments)			
	最大加速度 Maximum acceleration	G	0.37	0.73	1.47	
	滾珠螺桿 Ball screw	基本動額定負荷 Basic dynamic load rating Ca	N	7733	5855	3007
基本靜額定負荷 Basic static load rating Coa		N	14200	10401	5414	
直線滑軌 Linear Guide	動態水平負載 Dynamic horizontal (100km)	N	18601			
	靜態水平負載 Static Horizontal	N	34189			
固定側軸承 Fixed bearing	基本動額定負荷 Basic dynamic load rating Cr	N	8447			
	靜態容許負荷 Static load rating Cor	N	5060			
部品	AC 伺服馬達容量 AC Servo Motor Output	W	400			
	滾珠螺桿外徑 Ball Screw Ø	mm	C7Ø14			
	連軸器 Coupling	mm	10X14			
	原點感應器 Home Sensor	外掛 Outside	T64N2 (NPN+2 米線) (NPN+2M Cable)			

※1 長行程時，會產生螺桿偏擺，需將速度調降 (線速度請參閱尺寸圖下方表格)
During in a long stroke, it causes ballscrew deflection, the speed must reduce. (Please refer to the linear velocity from the data sheet below the dimension graph.)

容許負載力距表 Allowable Overhang

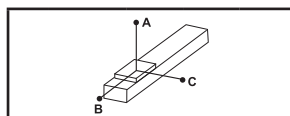

(單位 Unit: mm)

水平安裝 Horizontal Installation	A	B	C
導程 6 Lead	30kg	1900	261
	50kg	1080	88
	105kg	434	29
導程 12 Lead	25kg	780	175
	35kg	530	117
	85kg	175	33
導程 24 Lead	4kg	1400	820
	12kg	440	257
	40kg	109	60

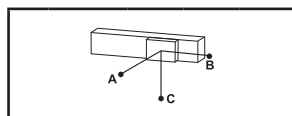

(單位 Unit: mm)

壁掛安裝 Wall Installation	A	B	C
導程 6 Lead	30kg	261	165
	50kg	140	88
	105kg	47	29
導程 12 Lead	25kg	240	175
	35kg	160	117
	85kg	46	33
導程 24 Lead	4kg	750	820
	12kg	235	257
	40kg	55	109

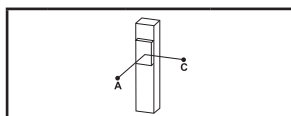

(單位 Unit: mm)

垂直安裝 Vertical Installation	A	C
導程 6 Lead	16kg	335
	30kg	180
	-	-
導程 12 Lead	12kg	400
	20kg	240
	-	-
導程 24 Lead	6kg	460
	10kg	275
	-	-

靜額定扭矩 Static Loading Moment

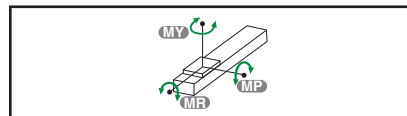

(單位 Unit: N.m)

MY	137
MP	137
MR	227

* 力矩表所表示的數據，代表荷重的重心位置於單一方向容許懸出的長度。
The data represented by the moment table is the center of gravity of the load. The length of the overhang is allowed in a single direction.
* 符合型錄規範的正常使用下，保證壽命為 10000 公里。
Operation life is 10,000km when the product is using under the specified conditions.
* 倒吊使用無法套用標準規範，如有需求請洽詢我司業務。
Data information is not for ceiling-mount inverse use.
Contact us for the details if you want to apply ceiling-mount inverse usage.
* 壽命及力矩是以馬達加減速設定 0.2 秒計算。
The life and torque are calculated by setting the motor acceleration and deceleration for 0.2 seconds.

選配 Options

MM

代號 Code	說明 Instructions	需參照 Refer to
MW	朝上 Upper side	P.111 ~ P.112
MM	朝下 Bottom side	
ML	朝左 Left side	
MR	朝右 Right side	

CMK

代號 Code	說明 Instructions			需參照 Refer to
	追加鍵槽 Keyway Groove	馬達位置 Motor Position	出貨型式 Shipment Type	
CMK	單邊 (限定馬達側) Single (Limited to the motor side)	BC	鍵槽式聯軸器 Keyway Coupling	P.113 ~ P.115
		BL/BR/BM	鍵槽式皮帶輪 Keyway Belt Pulley	
SKY	雙邊 Double	BC	鍵槽式聯軸器 Keyway Coupling	
		BL/BR/BM	鍵槽式皮帶輪 Keyway Belt Pulley	
SKN	雙邊 Double	BC	無聯軸器 (請自行購買安裝) Without Coupling (Please purchase and install by yourself)	
		BL/BR/BM	無馬達端皮帶輪 (請自行購買安裝) Without Belt Pulley (Please purchase and install by yourself)	



Download at www.toyorobot.com

BC 馬達外露 Motor Exposed

單位 Unit : mm

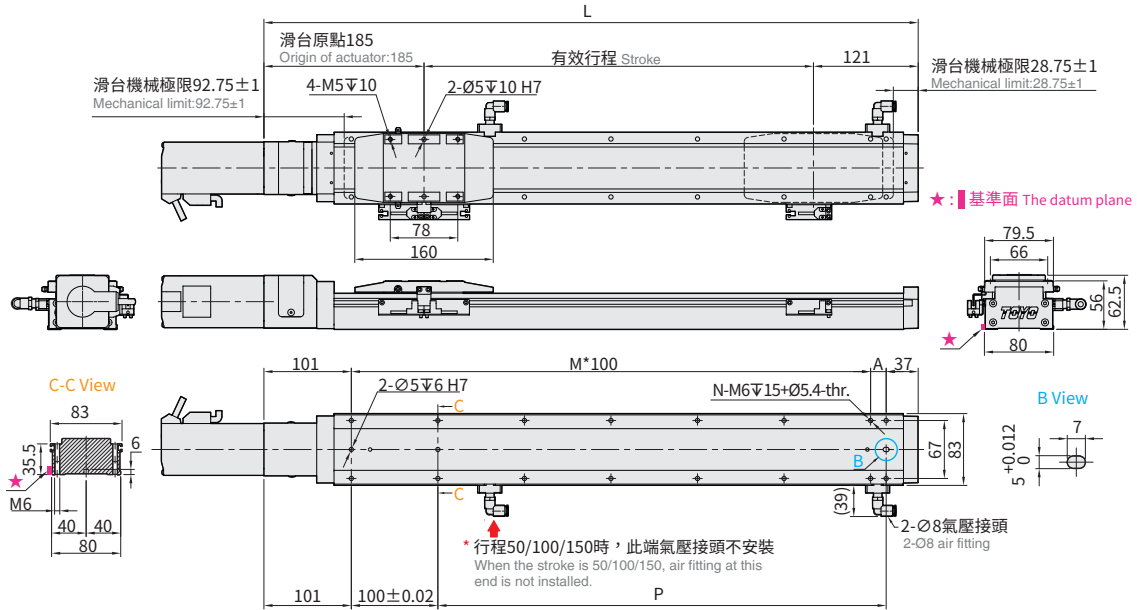

BM 馬達下折 Motor Bottom Side

單位 Unit : mm

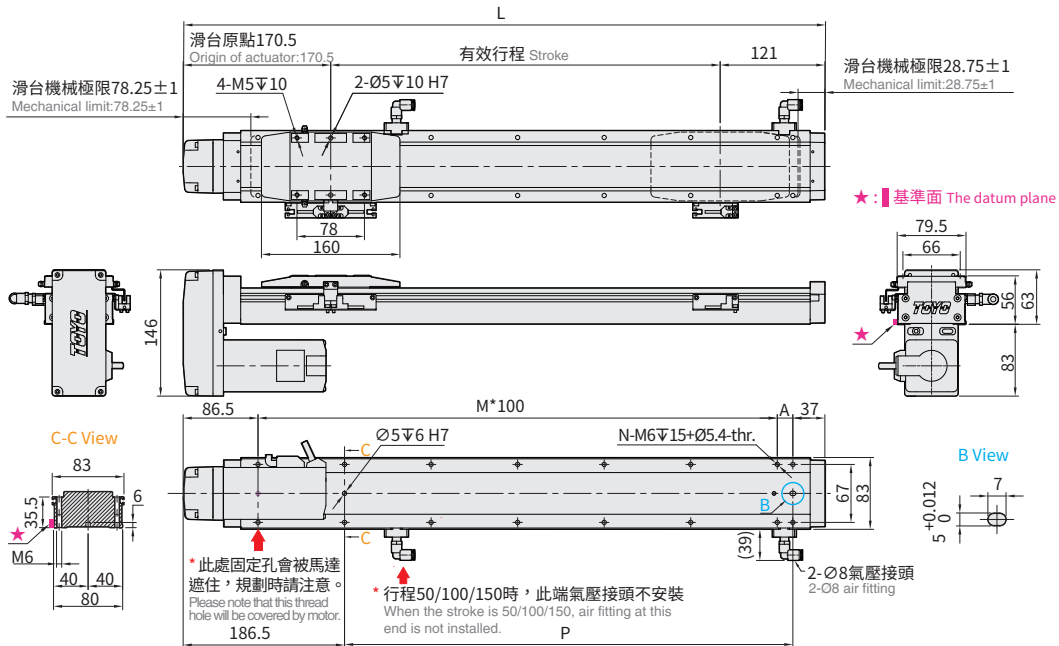

有效行程 Stroke	50 ⁻¹	100	150	200	250	300	350	400	450	500	550	600	650	700	750	800	850	900	950	1000	1050	1100	1150	1200	1250	
極限行程 Limit Stroke (±1)	74.5	124.5	174.5	224.5	274.5	324.5	374.5	424.5	474.5	524.5	574.5	624.5	674.5	724.5	774.5	824.5	874.5	924.5	974.5	1024.5	1074.5	1124.5	1174.5	1224.5	1274.5	
L	BC	356	406	456	506	556	606	656	706	756	806	856	906	956	1006	1056	1106	1156	1206	1256	1306	1356	1406	1456	1506	1556
	BM	341.5	391.5	441.5	491.5	541.5	591.5	641.5	691.5	741.5	791.5	841.5	891.5	941.5	991.5	1041.5	1091.5	1141.5	1191.5	1241.5	1291.5	1341.5	1391.5	1441.5	1491.5	1541.5
A	18	68	118	168	218	268	318	368	418	468	518	568	618	668	718	768	818	868	918	968	1018	1068	1118	1168	1218	1268
M	2	2	3	3	4	4	5	5	6	6	7	7	8	8	9	9	10	10	11	11	12	12	13	13	14	
N	8	8	10	10	12	12	14	14	16	16	18	18	20	20	22	22	24	24	26	26	28	28	30	30	32	
P	118	168	218	268	318	368	418	468	518	568	618	668	718	768	818	868	918	968	1018	1068	1118	1168	1218	1268	1318	
KG	BC	2.35	2.65	2.94	3.24	3.53	3.83	4.13	4.42	4.72	5.01	5.31	5.61	5.91	6.2	6.5	6.79	7.09	7.39	7.68	7.98	8.28	8.57	8.87	9.17	9.46
	BM	2.72	3.02	3.31	3.61	3.91	4.2	4.5	4.79	5.09	5.39	5.68	5.98	6.28	6.57	6.87	7.17	7.46	7.76	8.05	8.35	8.65	8.94	9.24	9.54	9.83
線速度 Linear Speed mm/s	導程 Lead 6											350	310	270	240	210	190	170	160	140	130	120	110	100	90	
	導程 Lead 12											700	620	540	480	420	380	340	320	280	260	240	220	200	180	
	導程 Lead 24											1400	1240	1080	960	840	760	680	640	560	520	480	440	400	360	

*1 行程 50 時，因本體上鎖式固定孔會被滑座遮住，僅能使用 4 支螺絲固定，建議客戶本體使用下鎖式固定孔鎖附。When the stroke is 50mm, if fixing the body from the top to the bottom, the fixing hole will be blocked by slider and only can be uses 4 screws to fix; as a result, suggest that fixing actuator body from the bottom to the top.



Download at www.toyorobot.com

BL 馬達左折 Motor Left Side

單位 Unit : mm

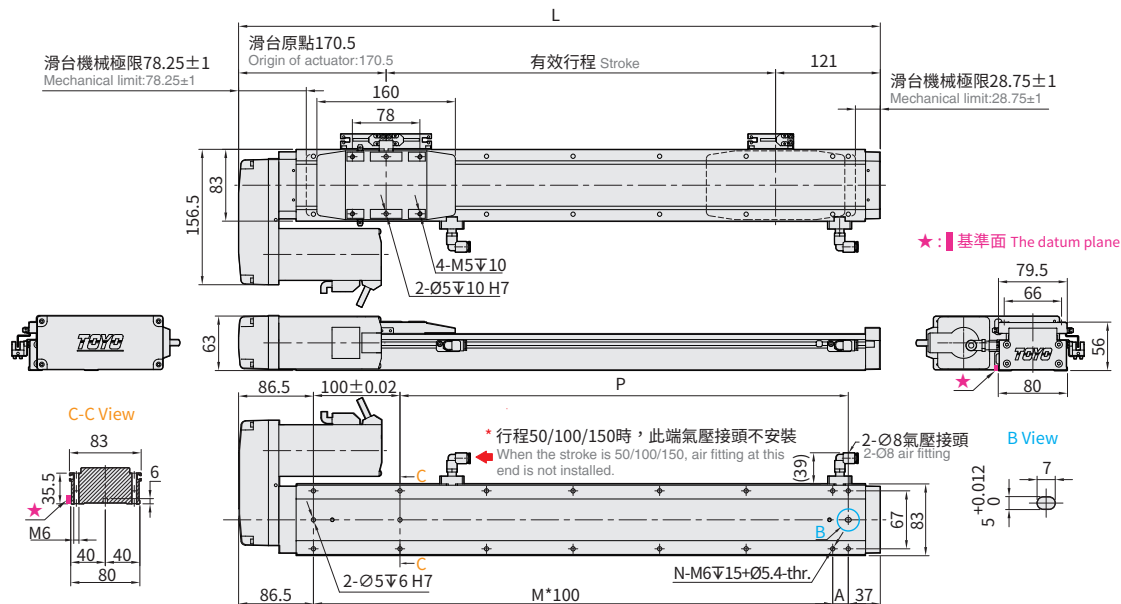

BR 馬達右折 Motor Right Side

單位 Unit : mm

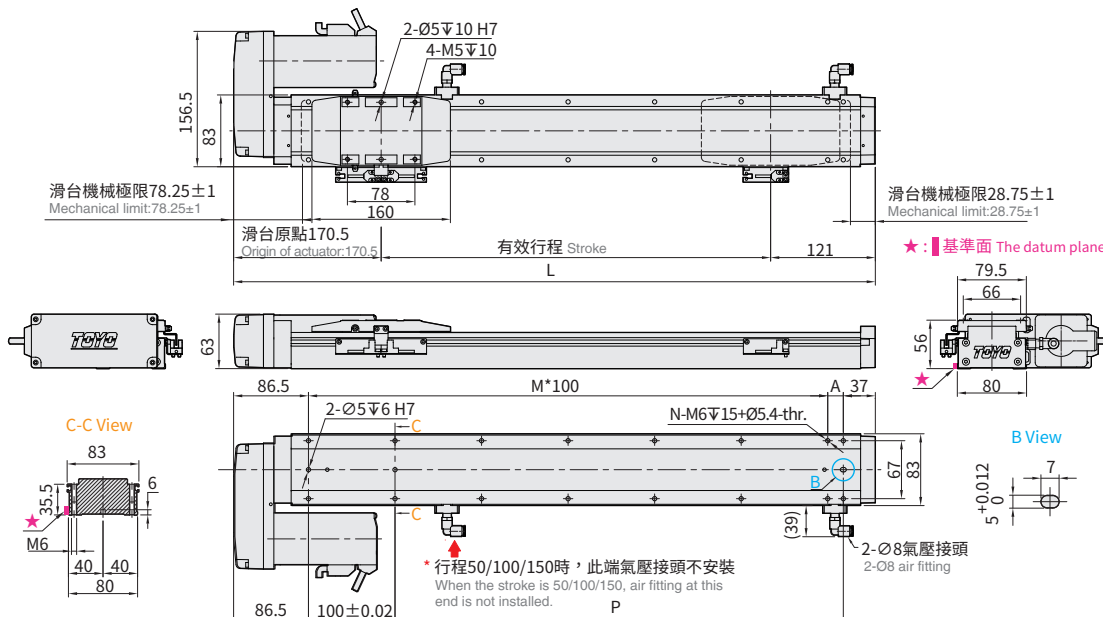

有效行程 Stroke	50 ^{±1}	100	150	200	250	300	350	400	450	500	550	600	650	700	750	800	850	900	950	1000	1050	1100	1150	1200	1250	
極限行程 Limit Stroke (±1)	74.5	124.5	174.5	224.5	274.5	324.5	374.5	424.5	474.5	524.5	574.5	624.5	674.5	724.5	774.5	824.5	874.5	924.5	974.5	1024.5	1074.5	1124.5	1174.5	1224.5	1274.5	
L	341.5	391.5	441.5	491.5	541.5	591.5	641.5	691.5	741.5	791.5	841.5	891.5	941.5	991.5	1041.5	1091.5	1141.5	1191.5	1241.5	1291.5	1341.5	1391.5	1441.5	1491.5	1541.5	
A	18	68	18	68	18	68	18	68	18	68	18	68	18	68	18	68	18	68	18	68	18	68	18	68	18	
M	2	2	3	3	4	4	5	5	6	6	7	7	8	8	9	9	10	10	11	11	12	12	13	13	14	
N	8	8	10	10	12	12	14	14	16	16	18	18	20	20	22	22	24	24	26	26	28	28	30	30	32	
P	118	168	218	268	318	368	418	468	518	568	618	668	718	768	818	868	918	968	1018	1068	1118	1168	1218	1268	1318	
KG	2.72	3.02	3.31	3.61	3.91	4.2	4.5	4.79	5.09	5.39	5.68	5.98	6.28	6.57	6.87	7.17	7.46	7.76	8.05	8.35	8.65	8.94	9.24	9.54	9.83	
線速度 Linear Speed mm/s	導程 Lead 6												350	310	270	240	210	190	170	160	140	130	120	110	100	90
	導程 Lead 12												700	620	540	480	420	380	340	320	280	260	240	220	200	180
	導程 Lead 24												1400	1240	1080	960	840	760	680	640	560	520	480	440	400	360

※1 行程 50 時，因本體上鎖式固定孔會被滑座遮住，僅能使用 4 支螺絲固定，建議客戶本體使用下鎖式固定孔鎖附。When the stroke is 50mm, if fixing the body from the top to the bottom, the fixing hole will be blocked by slider and only can be uses 4 screws to fix; as a result, suggest that fixing actuator body from the bottom to the top.

應用例
Application

無塵 / 螺桿仕様
GLCH

一般 / 皮帶仕様
ETB / M

無塵 / 螺桿仕様
GCH / ECH

無塵 / 皮帶仕様
ECB

直交連結
XYGT / XYTH / XYTB

參考資料
Reference

GLCH Series

GLCH5

GLCH8

GLCH12

GLCH5D

GLCH8D

GLCH12 單軸 /1-axis

▶ 軌道內嵌
Integrated Linear Bearing

▶ 螺桿驅動
Ball Screw Drive

精度
±0.005 mm

Clean Room



此圖僅供參考，出貨規格詳見尺寸圖面
The picture is just for the reference. Please check the the actual dimensions on the drawing.

最大行程
Maximum Stroke **1250mm**

最高速度
Maximum Speed **1440mm/s**

馬達容量
Motor Output **400W**

最大可搬重量
Max Payload **110kg**

型號表示方式 Ordering Method

GLCH12-L12-100-BC-M40B-C4N5- 參照右頁
Refer to the right page. -0001

本體型號
Model

行程^{*1}
Stroke

50-1250mm
50mm間隔 50 mm Pitch

選配
Options

特注式樣
Customization Order No.

馬達位置
Motor Position

BC	馬達外露 Motor Exposed
BM	馬達下折 Motor Bottom Side
BL	馬達左折 Motor Left Side
BR	馬達右折 Motor Right Side

馬達廠牌、功率
Motor Brand · Power Output

M	三菱 Mitsubishi	05	-	B ^{*2}
P	松下 Panasonic	10	-	
Y	安川 Yaskawa	20	-	
T	台達 Delta	40	400W	

原點感應器
Home Sensor

外掛型 Out Side	
C	馬達側 Motor Side
D	反馬達側 Opposite Motor Side
	無 SENSOR No Sensor
E	無 SENSOR No Sensor

端點極限感應器
Limit Sensor

外掛型 Out Side	
3	1只 1 Pc
4	2只 2 Pcs
6	3只 3 Pcs
7	4只 4 Pcs
8	5只 5 Pcs
9	6只 6 Pcs
	無 SENSOR No Sensor
5	無 SENSOR No Sensor

輸出方式&線長
Output type & Cable length

N5	NPN+5M線 NPN+5M Cable
P2	PNP+2M線 PNP+2M Cable
P5	PNP+5M線 PNP+5M Cable
-	NPN+2M線 NPN+2M Cable

螺桿導程
Ball Screw Lead

6	6mm
12	12mm
24	24mm

^{*1} 選擇行程50時，光電使用有以下限制：When the stroke is 50mm, the sensor installation has the following restrictions:

馬達方向 BC/BM：1.原點與極限需放置於不同側。2.滑座左右兩側皆需安裝感應片。Motor Direction BC/BM：1.Home sensor and limit sensor has to be installed on the different side of body. 2.Both sides of slider need to install the sensor trigger device.

馬達方向 BL/BR：1.原點+極限感應器最數量最多2只 (僅能選用C3/D3/E3/E4/E5)。Motor Direction BL/BR：1.Home + limit sensors is 2 maximum (only C3/D3/E3/E4/E5 can be selected)

^{*2} 馬達若無煞車則不表示。If Motor No Brake, No Description.

基本仕様 Specification

性能	位置重複精度 Repeatability	mm	±0.005			
	螺桿導程 Lead	mm	6	12	24	
	最高轉速 Maximum Rotating speed	rpm	3600	3600	3600	
	最高速度 Maximum linear speed ※1	mm/s	360	720	1440	
	最大可搬重量 Maximum Payload	水平使用 Horizontal	kg	110	88	40
		垂直使用 Vertical	kg	30	20	10
	定格推力 Rated Thrust	N	1156	578	289	
	標準行程 Stroke (increments)	mm	50-1250mm / 50 間隔 (50 increments)			
	最大加速度 Maximum acceleration	G	0.37	0.73	1.47	
	滾珠螺桿 Ball screw	基本動額定負荷 Basic dynamic load rating Ca	N	7733	5855	3007
基本靜額定負荷 Basic static load rating Coa		N	14200	10401	5414	
直線滑軌 Linear Guide	動態水平負載 Dynamic horizontal (100km)	N	51128			
	靜態水平負載 Static Horizontal	N	84518			
固定側軸承 Fixed bearing	基本動額定負荷 Basic dynamic load rating Cr	N	8447			
	靜態容許負荷 Static load rating Cor	N	5060			
部品	AC 伺服馬達容量 AC Servo Motor Output	W	400			
	滾珠螺桿外徑 Ball Screw Ø	mm	C7Ø14			
	連軸器 Coupling	mm	10X14			
	原點感應器 Home Sensor	外掛 Outside	T64N2 (NPN+2 米線) (NPN+2M Cable)			

※1 長行程時，會產生螺桿偏擺，需將速度調降 (線速度請參閱尺寸圖下方表格)
During in a long stroke, it causes ballscrew deflection, the speed must reduce. (Please refer to the linear velocity from the data sheet below the dimension graph.)

容許負載力距表 Allowable Overhang

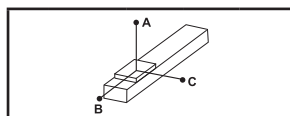

(單位 Unit : mm)

水平安裝 Horizontal Installation	A	B	C
導程 6 Lead	60kg	1900	268
	80kg	1428	113
	110kg	963	70
導程 12 Lead	60kg	1538	346
	70kg	1300	290
	88kg	1010	222
導程 24 Lead	20kg	1285	753
	30kg	835	487
	40kg	613	355

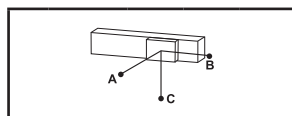

(單位 Unit : mm)

壁掛安裝 Wall Installation	A	B	C
導程 6 Lead	60kg	268	1990
	80kg	184	113
	110kg	114	70
導程 12 Lead	60kg	483	1538
	70kg	406	1300
	88kg	311	1010
導程 24 Lead	20kg	693	1285
	30kg	450	835
	40kg	328	613

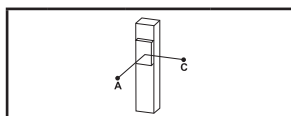

(單位 Unit : mm)

垂直安裝 Vertical Installation	A	C
導程 6 Lead	20kg	1250
	30kg	830
	-	-
導程 12 Lead	10kg	2250
	20kg	1120
	-	-
導程 24 Lead	7kg	1840
	10kg	1280
	-	-

靜額定扭矩 Static Loading Moment

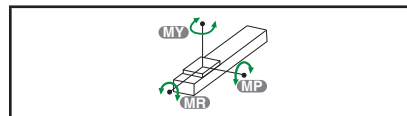

(單位 Unit : N.m)

MY	606
MP	606
MR	1168

* 力矩表所表示的數據，代表荷重的重心位置於單一方向容許懸出的長度。
The data represented by the moment table is the center of gravity of the load. The length of the overhang is allowed in a single direction.
* 符合型錄規範的正常使用下，保證壽命為 10000 公里。
Operation life is 10,000km when the product is using under the specified conditions.
* 倒吊使用無法套用標準規範，如有需求請洽詢我司業務。
Data information is not for ceiling-mount inverse use. Contact us for the details if you want to apply ceiling-mount inverse usage.
* 壽命及力矩是以馬達加速減速設定 0.2 秒計算。
The life and torque are calculated by setting the motor acceleration and deceleration for 0.2 seconds.

選配 Options

MM

指定馬達出線方向 Selectable Cable Leading Direction		
代號 Code	說明 Instructions	需參照 Refer to
MW	朝上 Upper side	P.111 ~ P.112
MM	朝下 Bottom side	
ML	朝左 Left side	
MR	朝右 Right side	

CMK

馬達傳動配件追加鍵槽 Additional keyway for motor drive parts				
代號 Code	說明 Instructions			需參照 Refer to
	追加鍵槽 Keyway Groove	馬達位置 Motor Position	出貨型式 Shipment Type	
CMK	單邊 (限定馬達側) Single (Limited to the motor side)	BC	鍵槽式聯軸器 Keyway Coupling	P.113 ~ P.115
		BL/BR/BM	鍵槽式皮帶輪 Keyway Belt Pulley	
SKY	雙邊 Double	BC	鍵槽式聯軸器 Keyway Coupling	
		BL/BR/BM	鍵槽式皮帶輪 Keyway Belt Pulley	
SKN	雙邊 Double	BC	無聯軸器 (請自行購買安裝) Without Coupling (Please purchase and install by yourself)	
		BL/BR/BM	無馬達端皮帶輪 (請自行購買安裝) Without Belt Pulley (Please purchase and install by yourself)	



Download at www.toyorobot.com

BC 馬達外露 Motor Exposed

單位 Unit : mm

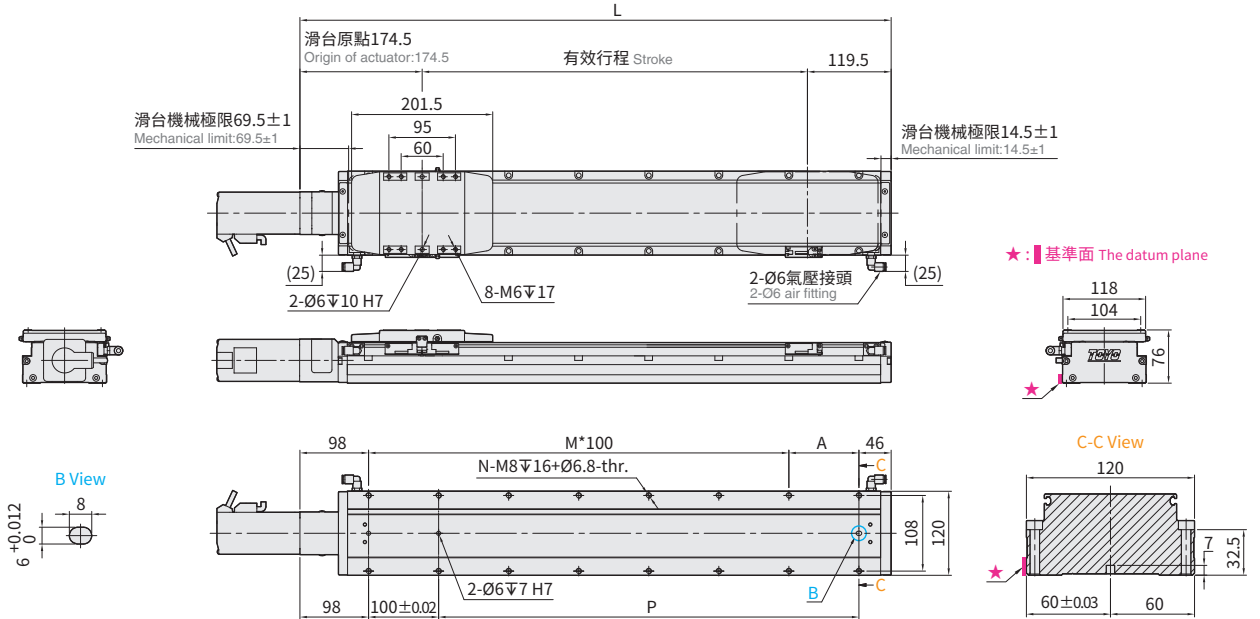

BM 馬達下折 Motor Bottom Side

單位 Unit : mm

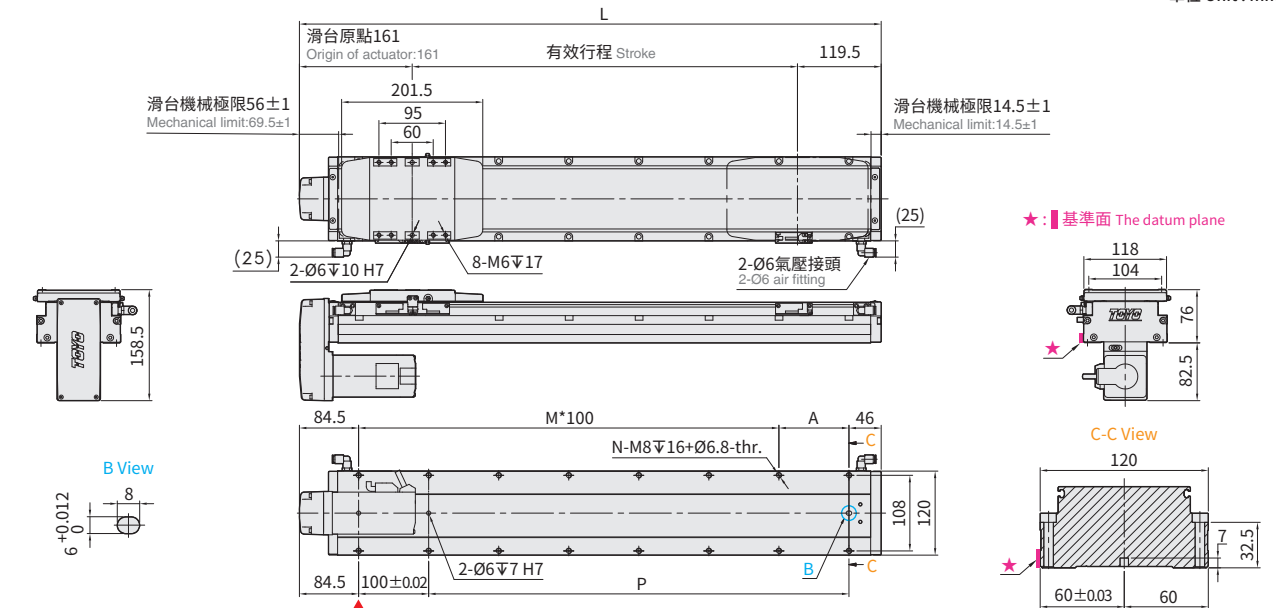

* 此處固定孔會被馬達遮住，規劃時請注意。
Please note that this thread hole will be covered by motor.

Ø6 氣壓接頭
Ø6 air fitting

有效行程 Stroke	50 ⁻¹	100	150	200	250	300	350	400	450	500	550	600	650	700	750	800	850	900	950	1000	1050	1100	1150	1200	1250	
極限行程 Limit Stroke (±1)	58.5	108.5	158.5	208.5	258.5	308.5	358.5	408.5	458.5	508.5	558.5	608.5	658.5	708.5	758.5	808.5	858.5	908.5	958.5	1008.5	1058.5	1108.5	1158.5	1208.5	1258.5	
L	BC	344	394	444	494	544	594	644	694	744	794	844	894	944	994	1044	1094	1144	1194	1244	1294	1344	1394	1444	1494	1544
	BM	330.5	380.5	430.5	480.5	530.5	580.5	630.5	680.5	730.5	780.5	830.5	880.5	930.5	980.5	1030.5	1080.5	1130.5	1180.5	1230.5	1280.5	1330.5	1380.5	1430.5	1480.5	1530.5
A	100	50	100	50	100	50	100	50	100	50	100	50	100	50	100	50	100	50	100	50	100	50	100	50	100	50
M	1	2	2	3	3	4	4	5	5	6	6	7	7	8	8	9	9	10	10	11	11	12	12	13	13	
N	6	8	8	10	10	12	12	14	14	16	16	18	18	20	20	22	22	24	24	26	26	28	28	30	30	
P	100	150	200	250	300	350	400	450	500	550	600	650	700	750	800	850	900	950	1000	1050	1100	1150	1200	1250	1300	
KG	BC	5.35	5.7	6.05	6.4	6.75	7.1	7.45	7.8	8.15	8.5	8.85	9.2	9.55	9.9	10.25	10.6	10.95	11.3	11.65	12	12.35	12.7	13.05	13.4	13.75
	BM	5.51	5.86	6.21	6.56	6.91	7.26	7.61	7.96	8.31	8.66	9.01	9.36	9.71	10.06	10.41	10.76	11.11	11.46	11.81	12.16	12.51	12.86	13.21	13.56	13.91
線速度 Linear Speed mm/s	導程 Lead 6	360										350	310	270	240	210	190	170	160	140	130	120	110	100		
	導程 Lead 12	720										700	620	540	480	420	380	340	320	280	260	240	220	200		
	導程 Lead 24	1440										1400	1240	1080	960	840	760	680	640	560	520	480	440	400		

* 1 行程 50 時，因本體上鎖式固定孔會被滑座遮住，僅能使用 4 支螺絲固定，建議客戶本體使用下鎖式固定孔鎖附。When the stroke is 50mm, if fixing the body from the top to the bottom, the fixing hole will be blocked by slider and only can be uses 4 screws to fix; as a result, suggest that fixing actuator body from the bottom to the top.



Download at www.toyorobot.com

BL 馬達左折 Motor Left Side

單位 Unit : mm

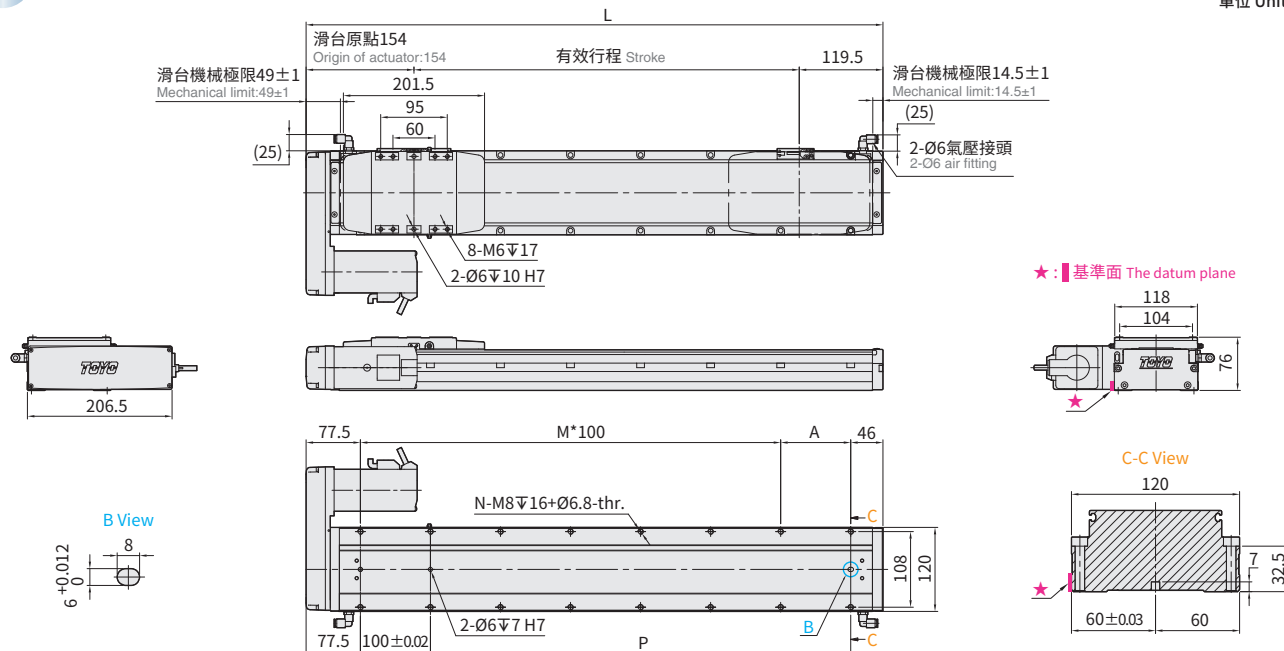

BR 馬達右折 Motor Right Side

單位 Unit : mm

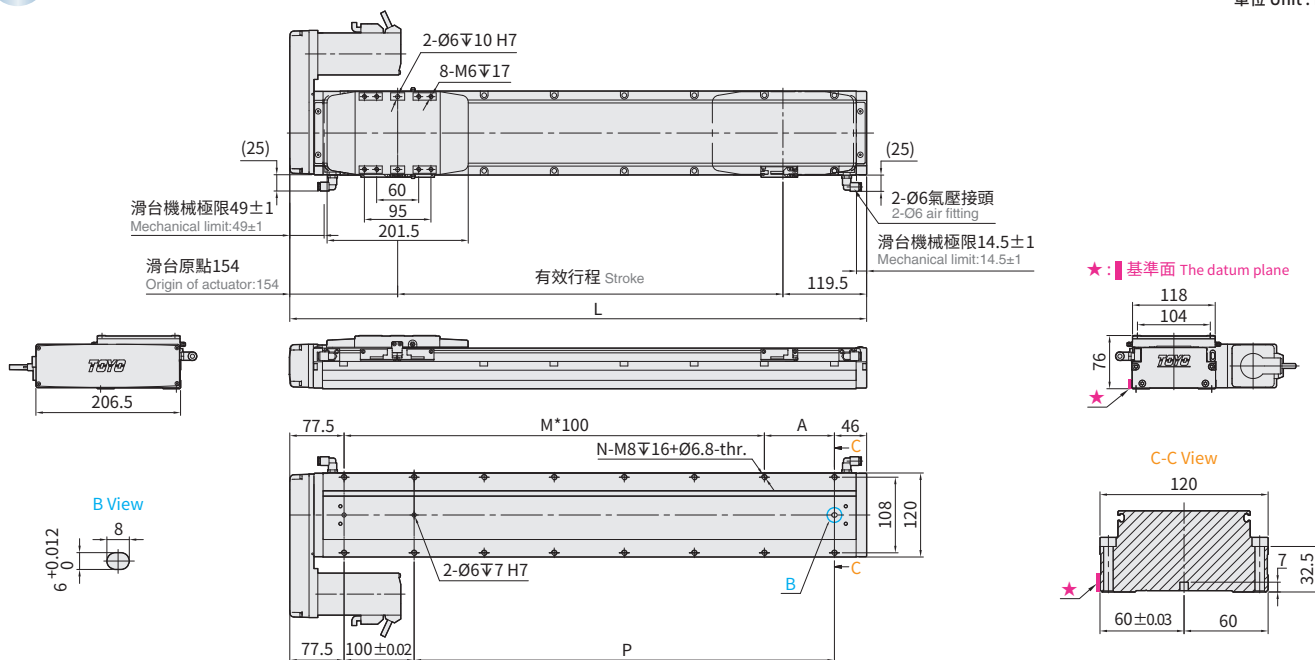

有效行程 Stroke	50 ⁻¹	100	150	200	250	300	350	400	450	500	550	600	650	700	750	800	850	900	950	1000	1050	1100	1150	1200	1250
極限行程 Limit Stroke (±1)	58.5	108.5	158.5	208.5	258.5	308.5	358.5	408.5	458.5	508.5	558.5	608.5	658.5	708.5	758.5	808.5	858.5	908.5	958.5	1008.5	1058.5	1108.5	1158.5	1208.5	1258.5
L	323.5	373.5	423.5	473.5	523.5	573.5	623.5	673.5	723.5	773.5	823.5	873.5	923.5	973.5	1023.5	1073.5	1123.5	1173.5	1223.5	1273.5	1323.5	1373.5	1423.5	1473.5	1523.5
A	100	50	100	50	100	50	100	50	100	50	100	50	100	50	100	50	100	50	100	50	100	50	100	50	100
M	1	2	2	3	3	4	4	5	5	6	6	7	7	8	8	9	9	10	10	11	11	12	12	13	13
N	6	8	8	10	10	12	12	14	14	16	16	18	18	20	20	22	22	24	24	26	26	28	28	30	30
P	100	150	200	250	300	350	400	450	500	550	600	650	700	750	800	850	900	950	1000	1050	1100	1150	1200	1250	1300
KG	5.55	5.9	6.25	6.6	6.95	7.3	7.65	8	8.35	8.7	9.05	9.4	9.75	10.1	10.45	10.8	11.15	11.5	11.85	12.2	12.55	12.9	13.25	13.6	13.95
線速度 Linear Speed mm/s	導程 Lead 6												360												
	導程 Lead 12												720												
	導程 Lead 24												1440												

※1行程50mm時，因本體上鎖式固定孔會被滑座遮住，僅能使用4支螺絲固定，建議客戶本體使用下鎖式固定孔鎖附。When the stroke is 50mm, if fixing the body from the top to the bottom, the fixing hole will be blocked by slider and only can be uses 4 screws to fix; as a result, suggest that fixing actuator body from the bottom to the top.

應用例
Application

無塵 / 螺桿仕様
GLCH

一般 / 皮帶仕様
ETB / M

無塵 / 螺桿仕様
GCH / ECH

無塵 / 皮帶仕様
ECB

直交連結
XYGT / XYTH / XYTB

參考資料
Reference

GLCH Series

GLCH5

GLCH8

GLCH12

GLCH5D

GLCH8D

GLCH5D 單軸 /1-axis

▶ 軌道內嵌
Integrated Linear Bearing

▶ 螺桿驅動
Ball Screw Drive

精度
±0.005 mm

Clean Room

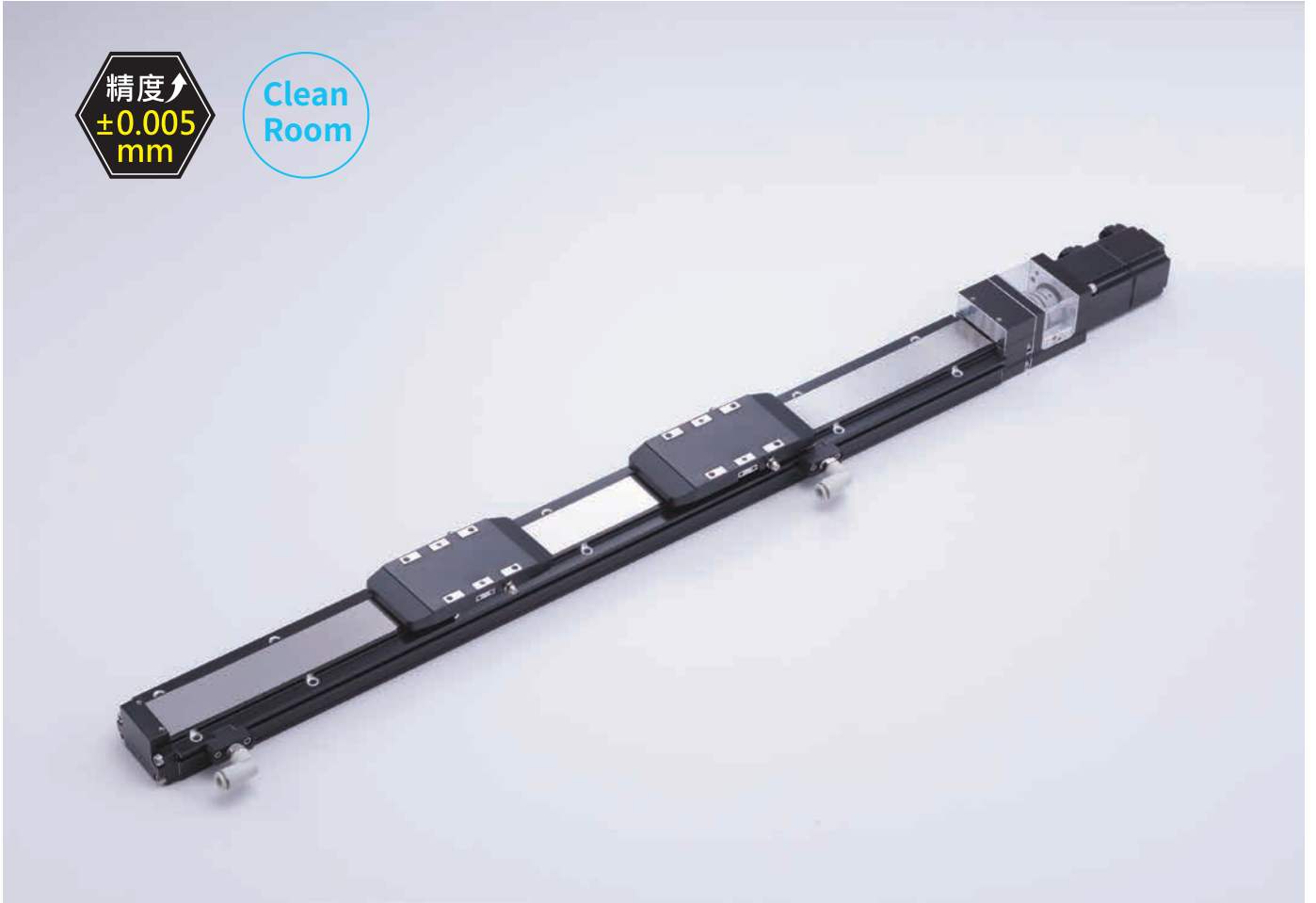

最大行程
Maximum Stroke **850mm**

最高速度
Maximum Speed **1200mm/s**

馬達容量
Motor Output **100W**

最大可搬重量
Max Payload **30kg**

型號表示方式 Ordering Method

GLCH5D - L2 - 100 - BC - M10B - C4N5 - 參照右頁 - 0001

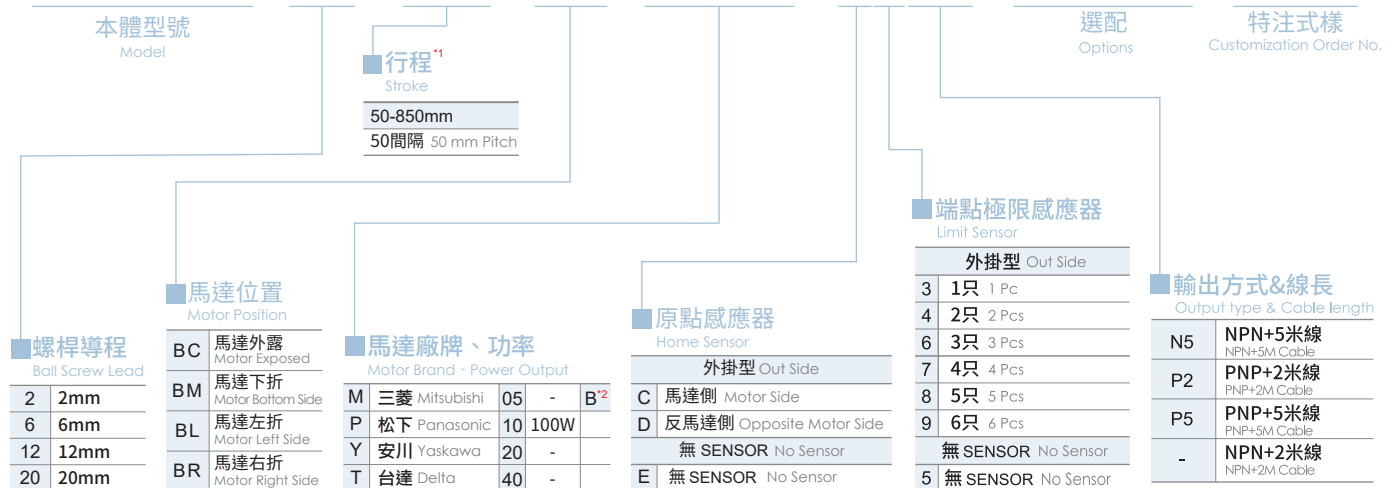

^{*1} 選擇行程50時，光電使用有以下限制：When the stroke is 50mm, the sensor installation has the following restrictions:

馬達方向 BC/BM：1.原點與極限需放置於不同側。2.滑座左右兩側皆需安裝感應片。Motor Direction BC/BM 1.Home sensor and limit sensor has to be installed on the different side of body. 2.Both sides of slider need to install the sensor trigger device.

馬達方向 BL/BR：1.原點+極限感應器最數量最多2只 (僅能選用C3/D3/E3/E4/E5)。Motor Direction BL/BR 1.Home + limit sensors is 2 maximum (only C3/D3/E3/E4/E5 can be selected)

^{*2} 馬達若無煞車則不表示。If Motor No Brake, No Description.

基本仕様 Specification

性能	位置重複精度 Repeatability	mm	±0.005				
	螺桿導程 Lead	mm	2	6	12	20	
	最高轉速 Maximum Rotating speed	rpm	3600	3600	3600	3600	
	最高速度 Maximum linear speed ※1	mm/s	120	300	720	1200	
	最大可搬重量 ※2 Maximum Payload	水平使用 Horizontal	kg	30	25	22	10
		垂直使用 Vertical	kg	10	6	4	3
	定格推力 Rated Thrust	N	854	285	142	85	
	標準行程 Stroke (increments)	mm	50-850mm / 50 間隔 (50 increments)				
	最大加速度 Maximum acceleration	G	0.12	0.37	0.73	1.22	
	滾珠螺桿 Ball screw	基本動額定負荷 Basic dynamic load rating Ca	N	2270	2243	1436	1384
基本靜額定負荷 Basic static load rating Coa		N	4836	3959	2441	2535	
直線滑軌 Linear Guide	動態水平負載 Dynamic horizontal (100km)	N	6563				
	靜態水平負載 Static Horizontal	N	13587				
固定側軸承 Fixed bearing	基本動額定負荷 Basic dynamic load rating Cr	N	5361				
	靜態容許負荷 Static load rating Cor	N	2880				
部品	AC 伺服馬達容量 AC Servo Motor Output	W	100				
	滾珠螺桿外徑 Ball Screw Ø	mm	C7Ø10				
	連軸器 Coupling	mm	7X8				
	原點感應器 Home Sensor	外掛 Outside	T64N2 (NPN+2 米線) (NPN+2M Cable)				

※1 長行程時，會產生螺桿偏擺，需將速度調降 (線速度請參閱尺寸圖下方表格)

During in a long stroke, it causes ballscrew deflection, the speed must reduce. (Please refer to the linear velocity from the data sheet below the dimension graph.)

※2 由於各廠牌的馬達性能不同，需適度搭配回升電阻以達到此荷重條件。

Since the motor performance of each brand is different, a regenerative resistor needs to be appropriately matched to achieve this load condition.

容許負載力距表 Allowable Overhang

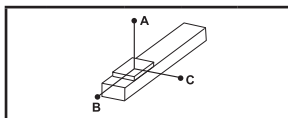

(單位 Unit: mm)

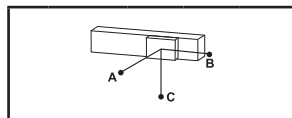

(單位 Unit: mm)

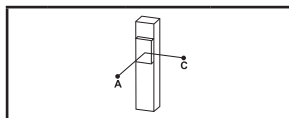

(單位 Unit: mm)

水平安裝 Horizontal Installation		A	B	C
導程 2 Lead	10kg	2500	157	250
	20kg	1120	70	112
	30kg	650	41	65
導程 6 Lead	10kg	1400	122	184
	20kg	650	52	79
	25kg	490	38	57
導程 12 Lead	8kg	590	132	175
	10kg	460	103	135
	22kg	185	37	49
導程 20 Lead	3kg	656	300	303
	6kg	314	141	144
	10kg	177	78	79

壁掛安裝 Wall Installation		A	B	C
導程 2 Lead	10kg	250	157	2500
	20kg	112	70	1120
	30kg	65	41	650
導程 6 Lead	10kg	184	122	1400
	20kg	79	52	650
	25kg	57	38	490
導程 12 Lead	8kg	175	132	590
	10kg	135	103	460
	22kg	49	37	185
導程 20 Lead	3kg	303	300	656
	6kg	144	141	314
	10kg	79	78	177

垂直安裝 Vertical Installation		A	C
導程 2 Lead	5kg	346	346
	10kg	173	173
	-	-	-
導程 6 Lead	3kg	463	463
	6kg	231	231
	-	-	-
導程 12 Lead	2.5kg	465	465
	4kg	292	292
	-	-	-
導程 20 Lead	1.5kg	555	555
	3kg	278	278
	-	-	-

靜額定扭矩 Static Loading Moment

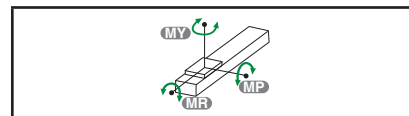

(單位 Unit: N.m)

MY	73
MP	73
MR	115

* 力矩表所表示的數據，代表荷重的重心位置於單一方向容許懸出的長度。
The data represented by the moment table is the center of gravity of the load. The length of the overhang is allowed in a single direction.

* 符合型錄規範的正常使用下，保證壽命為 10000 公里。

Operation life is 10,000km when the product is using under the specified conditions.

* 倒吊使用無法套用標準規範，如有需求請洽詢我司業務。

Data information is not for ceiling-mount inverse use.

Contact us for the details if you want to apply ceiling-mount inverse usage.

* 壽命及力矩是以馬達加減速設定 0.2 秒計算。

The life and torque are calculated by setting the motor acceleration and deceleration for 0.2 seconds.

選配 Options

MM

指定馬達出線方向 Selectable Cable Leading Direction		
代號 Code	說明 Instructions	需參照 Refer to
MW	朝上 Upper side	P.111 ~ P.112
MM	朝下 Bottom side	
ML	朝左 Left side	
MR	朝右 Right side	

CMK

馬達傳動配件追加鍵槽 Additional keyway for motor drive parts				
代號 Code	說明 Instructions			需參照 Refer to
	追加鍵槽 Keyway Groove	馬達位置 Motor Position	出貨型式 Shipment Type	
CMK	單邊 (限定馬達側) Single (Limited to the motor side)	BC	鍵槽式聯軸器 Keyway Coupling	P.113 ~ P.115
		BL/BR/BM	鍵槽式皮帶輪 Keyway Belt Pulley	
SKY	雙邊 Double	BC	鍵槽式聯軸器 Keyway Coupling	
		BL/BR/BM	鍵槽式皮帶輪 Keyway Belt Pulley	
SKN	雙邊 Double	BC	無聯軸器 (請自行購買安裝) Without Coupling (Please purchase and install by yourself)	
		BL/BR/BM	無馬達端皮帶輪 (請自行購買安裝) Without Belt Pulley (Please purchase and install by yourself)	

GLCH5D 單軸 / 1-axis

▶ 軌道內嵌
Integrated Linear Bearing

▶ 螺桿驅動
Ball Screw Drive



Download at www.toyorobot.com

BC 馬達外露 Motor Exposed

單位 Unit : mm

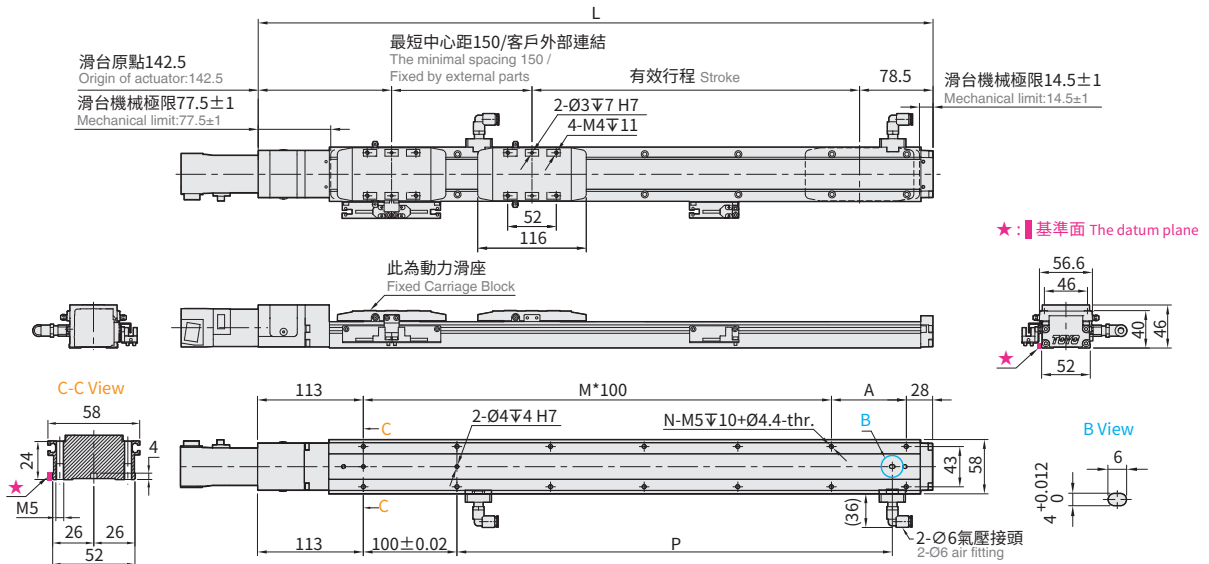

BM 馬達下折 Motor Bottom Side

單位 Unit : mm

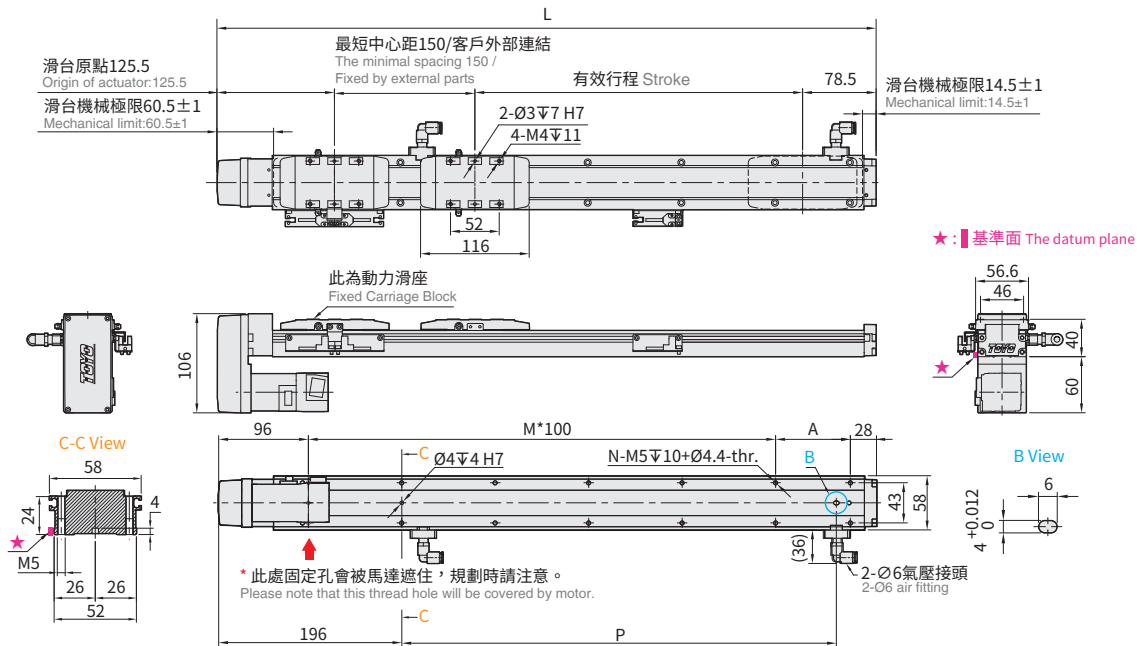

有效行程 Stroke	50 ^{±1}	100	150	200	250	300	350	400	450	500	550	600	650	700	750	800	850
極限行程 Limit Stroke (±1)	63	113	163	213	263	313	363	413	463	513	563	613	663	713	763	813	863
L	BC	421	471	521	571	621	671	721	771	821	871	921	971	1021	1071	1121	1221
	BM	404	454	504	554	604	654	704	754	804	854	904	954	1004	1054	1104	1204
A	80	30	80	30	80	30	80	30	80	30	80	30	80	30	80	30	80
M	2	3	3	4	4	5	5	6	6	7	7	8	8	9	9	10	10
N	8	10	10	12	12	14	14	16	16	18	18	20	20	22	22	24	24
P	165	215	265	315	365	415	465	515	565	615	665	715	765	815	865	915	965
KG	BC	1.61	1.74	1.86	1.99	2.12	2.24	2.37	2.50	2.62	2.75	2.88	3.00	3.13	3.25	3.38	3.51
	BM	1.71	1.84	1.96	2.09	2.22	2.34	2.47	2.60	2.72	2.85	2.98	3.10	3.23	3.35	3.48	3.61
線速度 Linear Speed mm/s	導程 Lead 2							110	90	80	70	63	53	50	43	40	36
	導程 Lead 6							330	270	240	210	190	160	150	130	120	110
	導程 Lead 12							660	540	480	420	380	320	300	260	240	220
	導程 Lead 20							1100	900	800	700	633	533	500	433	400	367

*1 行程 50 時，因本體上鎖式固定孔會被滑座遮住，僅能使用 4 支螺絲固定，建議客戶本體使用下鎖式固定孔鎖附。When the stroke is 50mm, if fixing the body from the top to the bottom, the fixing hole will be blocked by slider and only can be uses 4 screws to fix, as a result, suggest that fixing actuator body from the bottom to the top.



Download at www.toyorobot.com

BL 馬達左折 Motor Left Side

單位 Unit : mm

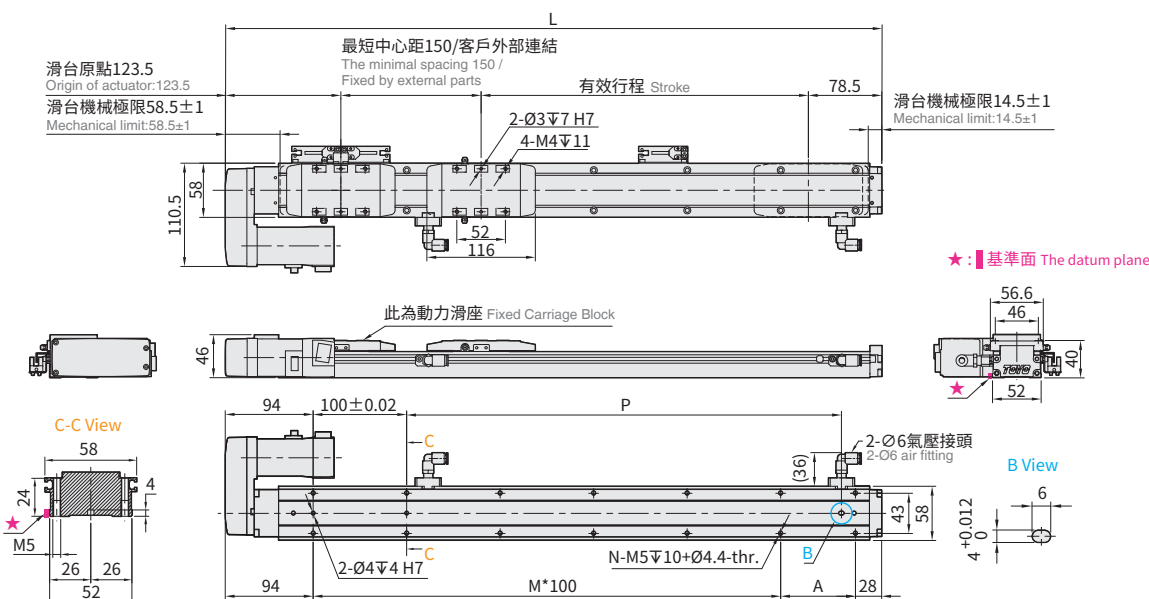

BR 馬達右折 Motor Right Side

單位 Unit : mm

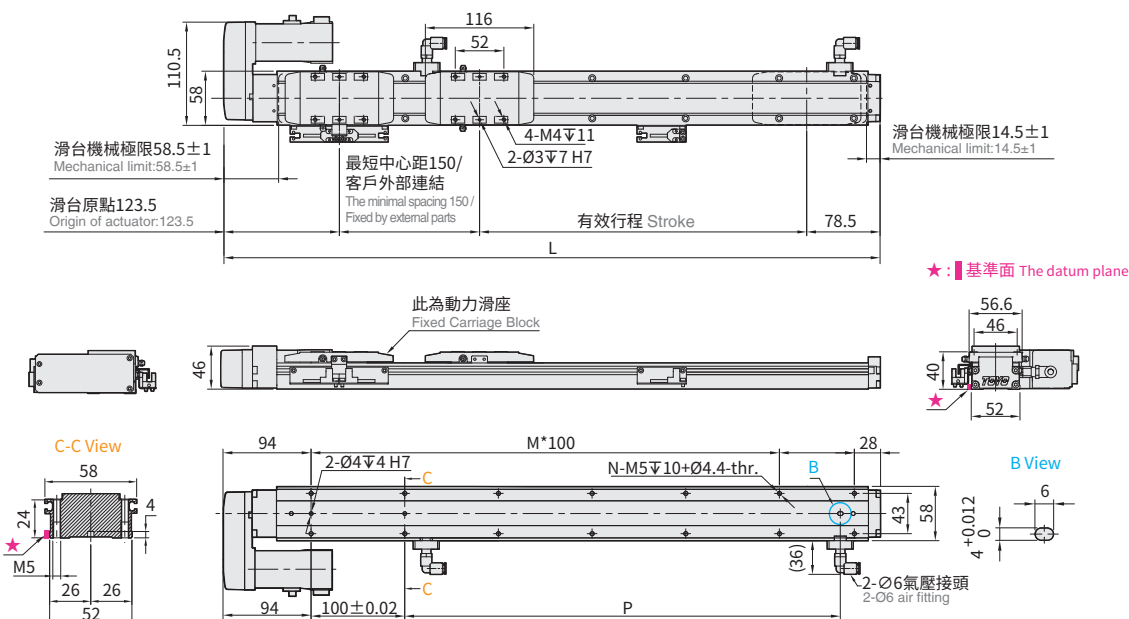

有效行程 Stroke	50 ⁻¹	100	150	200	250	300	350	400	450	500	550	600	650	700	750	800	850
極限行程 Limit Stroke (±1)	63	113	163	213	263	313	363	413	463	513	563	613	663	713	763	813	863
L	402	452	502	552	602	652	702	752	802	852	902	952	1002	1052	1102	1152	1202
A	80	30	80	30	80	30	80	30	80	30	80	30	80	30	80	30	80
M	2	3	3	4	4	5	5	6	6	7	7	8	8	9	9	10	10
N	8	10	10	12	12	14	14	16	16	18	18	20	20	22	22	24	24
P	165	215	265	315	365	415	465	515	565	615	665	715	765	815	865	915	965
KG	1.71	1.84	1.96	2.09	2.22	2.34	2.47	2.60	2.72	2.85	2.98	3.10	3.23	3.35	3.48	3.61	3.73
線速度 Linear Speed mm/s	導程 Lead 2							110	90	80	70	63	53	50	43	40	36
	導程 Lead 6							330	270	240	210	190	160	150	130	120	110
	導程 Lead 12							660	540	480	420	380	320	300	260	240	220
	導程 Lead 20							1100	900	800	700	633	533	500	433	400	367

※1行程50時，因本體上鎖式固定孔會被滑座遮住，僅能使用4支螺絲固定，建議客戶本體使用下鎖式固定孔鎖附。When the stroke is 50mm, if fixing the body from the top to the bottom, the fixing hole will be blocked by slider and only can be uses 4 screws to fix; as a result, suggest that fixing actuator body from the bottom to the top.

應用例
Application

無塵/螺桿仕様
GLCH

一般/皮帶仕様
ETB/M

無塵/螺桿仕様
GCH/ECH

無塵/皮帶仕様
ECB

直交連結
XYGT/XYTH/XYTB

參考資料
Reference

GLCH Series

GLCH5

GLCH8

GLCH12

GLCH5D

GLCH8D

GLCH8D 單軸 /1-axis

▶ 軌道內嵌
Integrated Linear Bearing

▶ 螺桿驅動
Ball Screw Drive

精度
±0.005 mm

Clean Room

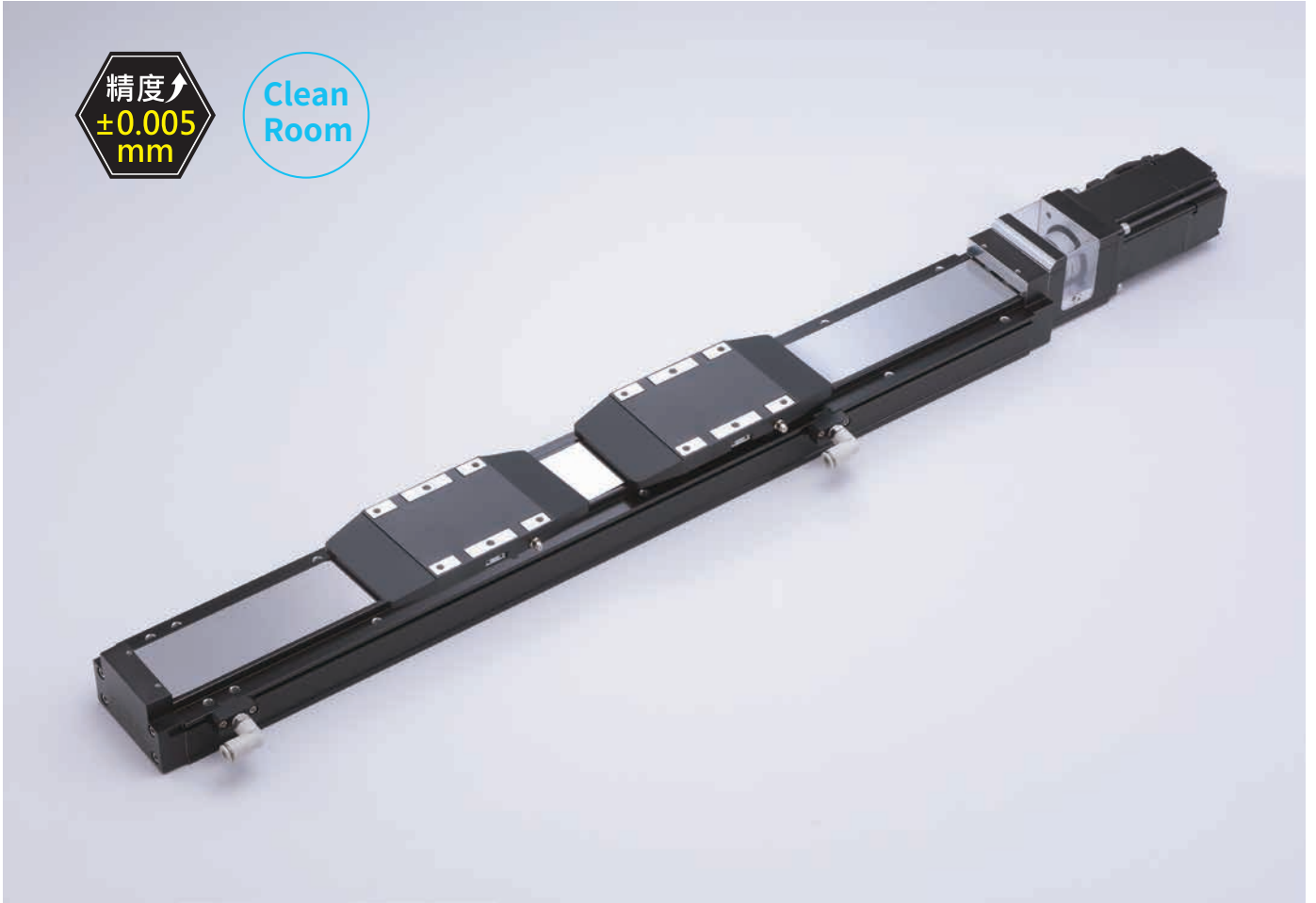

最大行程
Maximum Stroke 1050mm

最高速度
Maximum Speed 1440mm/s

馬達容量
Motor Output 200W

最大可搬重量
Max Payload 80kg

型號表示方式 Ordering Method

GLCH8D - L6 - 100 - BC - M20B - C4N5 - 參照右頁 - 0001

本體型號
Model

行程^{*1}
Stroke
50-1050mm
50間隔 50 mm Pitch

選配
Options

特注式樣
Customization Order No.

螺桿導程
Ball Screw Lead

6	6mm
12	12mm
24	24mm

馬達位置
Motor Position

BC	馬達外露 Motor Exposed
BM	馬達下折 Motor Bottom Side
BL	馬達左折 Motor Left Side
BR	馬達右折 Motor Right Side

馬達廠牌、功率
Motor Brand · Power Output

M	三菱 Mitsubishi	05	-	B ^{*2}
P	松下 Panasonic	10	-	
Y	安川 Yaskawa	20	200W	
T	台達 Delta	40	-	

原點感應器
Home Sensor

外掛型 Out Side	
C	馬達側 Motor Side
D	反馬達側 Opposite Motor Side
無 SENSOR No Sensor	
E	無 SENSOR No Sensor

端點極限感應器
Limit Sensor

外掛型 Out Side	
3	1只 1 Pc
4	2只 2 Pcs
6	3只 3 Pcs
7	4只 4 Pcs
8	5只 5 Pcs
9	6只 6 Pcs
無 SENSOR No Sensor	
5	無 SENSOR No Sensor

輸出方式&線長
Output type & Cable length

N5	PNP+5米線 NPN+5M Cable
P2	PNP+2米線 PNP+2M Cable
P5	PNP+5米線 PNP+5M Cable
-	PNP+2米線 NPN+2M Cable

^{*1} 選擇行程50時，光電使用有以下限制：When the stroke is 50mm, the sensor installation has the following restrictions:

馬達方向 BC/BM：1.原點與極限需放置於不同側。2.滑座左右兩側皆需安裝感應片。Motor Direction BC/BM 1.Home sensor and limit sensor has to be installed on the different side of body. 2.Both sides of slider need to install the sensor trigger device.

馬達方向 BL/BR：1.原點+極限感應器最數量最多2只(僅能選用C3/D3/E3/E4/E5)。Motor Direction BL/BR 1.Home + limit sensors is 2 maximum (only C3/D3/E3/E4/E5 can be selected)

^{*2} 馬達若無煞車則不表示。If Motor No Brake, No Description.

基本仕様 Specification

性能	位置重複精度 Repeatability	mm	±0.005			
	螺桿導程 Lead	mm	6	12	24	
	最高轉速 Maximum Rotating speed	rpm	3600	3600	3600	
	最高速度 Maximum linear speed ※1	mm/s	360	720	1440	
	最大可搬重量 ※2 Maximum Payload	水平使用 Horizontal	kg	80	60	40
		垂直使用 Vertical	kg	15	8	5
	定格推力 Rated Thrust	N	569	284	142	
	標準行程 Stroke (increments)	mm	50-1050mm / 50 間隔 (50 increments)			
	最大加速度 Maximum acceleration	G	0.37	0.73	1.47	
	滾珠螺桿 Ball screw	基本動額定負荷 Basic dynamic load rating Ca	N	7733	5855	3007
		基本靜額定負荷 Basic static load rating Coa	N	14200	10401	5414
	直線滑軌 Linear Guide	動態水平負載 Dynamic horizontal (100km)	N	18601		
靜態水平負載 Static Horizontal		N	34189			
固定側軸承 Fixed bearing	基本動額定負荷 Basic dynamic load rating Cr	N	8447			
	靜態容許負荷 Static load rating Cor	N	5060			
部品	AC 伺服馬達容量 AC Servo Motor Output	W	200			
	滾珠螺桿外徑 Ball Screw Ø	mm	C7Ø14			
	連軸器 Coupling	mm	10X14 / 11 ※3			
	原點感應器 Home Sensor	外掛 Outside	T64N2 (NPN+2 米線) (NPN+2M Cable)			

※1 長行程時，會產生螺桿偏擺，需將速度調降 (線速度請參閱尺寸圖下方表格)
During in a long stroke, it causes ballscrew deflection, the speed must reduce. (Please refer to the linear velocity from the data sheet below the dimension graph.)
※2 由於各廠牌的馬達性能不同，需適度搭配回升電阻以達到此荷重條件。
Since the motor performance of each brand is different, a regenerative resistor needs to be appropriately matched to achieve this load condition.
※3 使用 Panasonic 200W 馬達時，馬達軸心為 Ø11；其他廠牌，馬達軸心為 Ø14。Motor (200W) Shaft Diameter: Panasonic: 11mm; Other: 14mm.

容許負載力距表 Allowable Overhang

(單位 Unit: mm)	(單位 Unit: mm)	(單位 Unit: mm)																																												
<table border="1"> <tr> <th>水平安裝 Horizontal Installation</th> <th>A</th> <th>B</th> <th>C</th> </tr> <tr> <td>導程 6 Lead</td> <td>35kg 1600</td> <td>139 102</td> <td>220 160</td> </tr> <tr> <td>導程 12 Lead</td> <td>10kg 2040</td> <td>470 645</td> <td>645 2040</td> </tr> <tr> <td>導程 24 Lead</td> <td>20kg 253</td> <td>145 109</td> <td>133 55</td> </tr> </table>	水平安裝 Horizontal Installation	A	B	C	導程 6 Lead	35kg 1600	139 102	220 160	導程 12 Lead	10kg 2040	470 645	645 2040	導程 24 Lead	20kg 253	145 109	133 55	<table border="1"> <tr> <th>壁掛安裝 Wall Installation</th> <th>A</th> <th>B</th> <th>C</th> </tr> <tr> <td>導程 6 Lead</td> <td>35kg 220</td> <td>139 102</td> <td>1600 1210</td> </tr> <tr> <td>導程 12 Lead</td> <td>10kg 645</td> <td>470 645</td> <td>2040 645</td> </tr> <tr> <td>導程 24 Lead</td> <td>20kg 133</td> <td>145 109</td> <td>253 55</td> </tr> </table>	壁掛安裝 Wall Installation	A	B	C	導程 6 Lead	35kg 220	139 102	1600 1210	導程 12 Lead	10kg 645	470 645	2040 645	導程 24 Lead	20kg 133	145 109	253 55	<table border="1"> <tr> <th>垂直安裝 Vertical Installation</th> <th>A</th> <th>C</th> </tr> <tr> <td>導程 6 Lead</td> <td>10kg 535</td> <td>535 360</td> </tr> <tr> <td>導程 12 Lead</td> <td>3.5kg 1380</td> <td>1380 605</td> </tr> <tr> <td>導程 24 Lead</td> <td>2kg 1380</td> <td>1380 556</td> </tr> </table>	垂直安裝 Vertical Installation	A	C	導程 6 Lead	10kg 535	535 360	導程 12 Lead	3.5kg 1380	1380 605	導程 24 Lead	2kg 1380	1380 556
水平安裝 Horizontal Installation	A	B	C																																											
導程 6 Lead	35kg 1600	139 102	220 160																																											
導程 12 Lead	10kg 2040	470 645	645 2040																																											
導程 24 Lead	20kg 253	145 109	133 55																																											
壁掛安裝 Wall Installation	A	B	C																																											
導程 6 Lead	35kg 220	139 102	1600 1210																																											
導程 12 Lead	10kg 645	470 645	2040 645																																											
導程 24 Lead	20kg 133	145 109	253 55																																											
垂直安裝 Vertical Installation	A	C																																												
導程 6 Lead	10kg 535	535 360																																												
導程 12 Lead	3.5kg 1380	1380 605																																												
導程 24 Lead	2kg 1380	1380 556																																												

靜額定扭矩 Static Loading Moment

	(單位 Unit: N.m)
MY	137
MP	137
MR	227

* 力矩表所表示的數據，代表荷重的重心位置於單一方向容許懸出的長度。
The data represented by the moment table is the center of gravity of the load. The length of the overhang is allowed in a single direction.
* 符合型錄規範的正常情況下，保證壽命為 10000 公里。
Operation life is 10,000km when the product is using under the specified conditions.
* 倒吊使用無法套用標準規範，如有需求請洽詢我司業務。
Data information is not for ceiling-mount inverse use. Contact us for the details if you want to apply ceiling-mount inverse usage.
* 壽命及力矩是以馬達加速減速設定 0.2 秒計算。
The life and torque are calculated by setting the motor acceleration and deceleration for 0.2 seconds.

選配 Options

MM

指定馬達出線方向 Selectable Cable Leading Direction		
代號 Code	說明 Instructions	需參照 Refer to
MW	朝上 Upper side	P.111 ~ P.112
MM	朝下 Bottom side	
ML	朝左 Left side	
MR	朝右 Right side	

CMK

馬達傳動配件追加鍵槽 Additional keyway for motor drive parts				
代號 Code	說明 Instructions			需參照 Refer to
	追加鍵槽 Keyway Groove	馬達位置 Motor Position	出貨型式 Shipment Type	
CMK	單邊 (限定馬達側) Single (Limited to the motor side)	BC	鍵槽式聯軸器 Keyway Coupling	P.113 ~ P.115
		BL/BR/BM	鍵槽式皮帶輪 Keyway Belt Pulley	
SKY	雙邊 Double	BC	鍵槽式聯軸器 Keyway Coupling	
		BL/BR/BM	鍵槽式皮帶輪 Keyway Belt Pulley	
SKN	雙邊 Double	BC	無聯軸器 (請自行購買安裝) Without Coupling (Please purchase and install by yourself)	
		BL/BR/BM	無馬達端皮帶輪 (請自行購買安裝) Without Belt Pulley (Please purchase and install by yourself)	



Download at www.toyorobot.com

BC 馬達外露 Motor Exposed

單位 Unit : mm

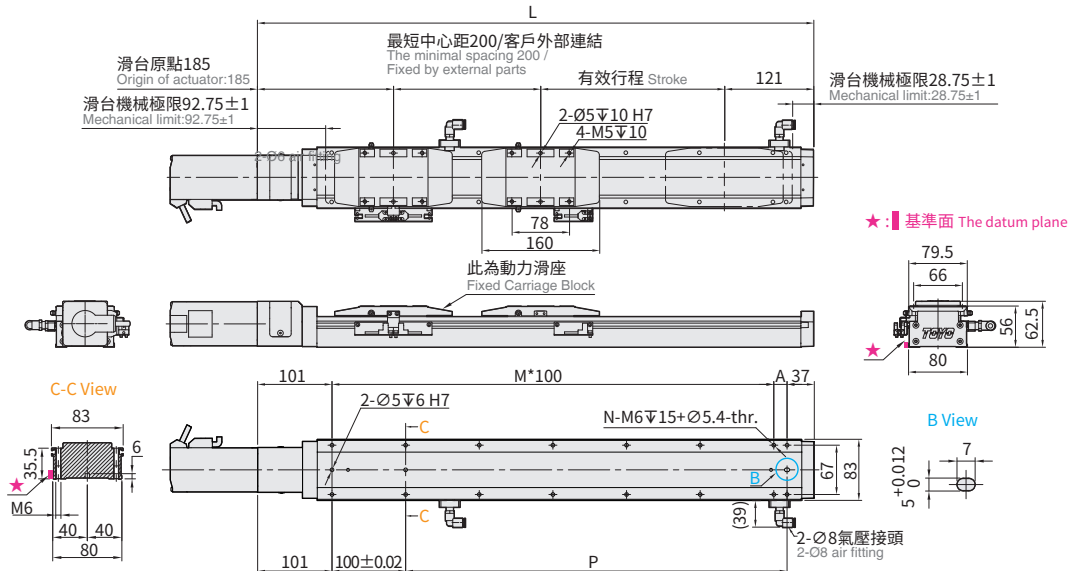

BM 馬達下折 Motor Bottom Side

單位 Unit : mm

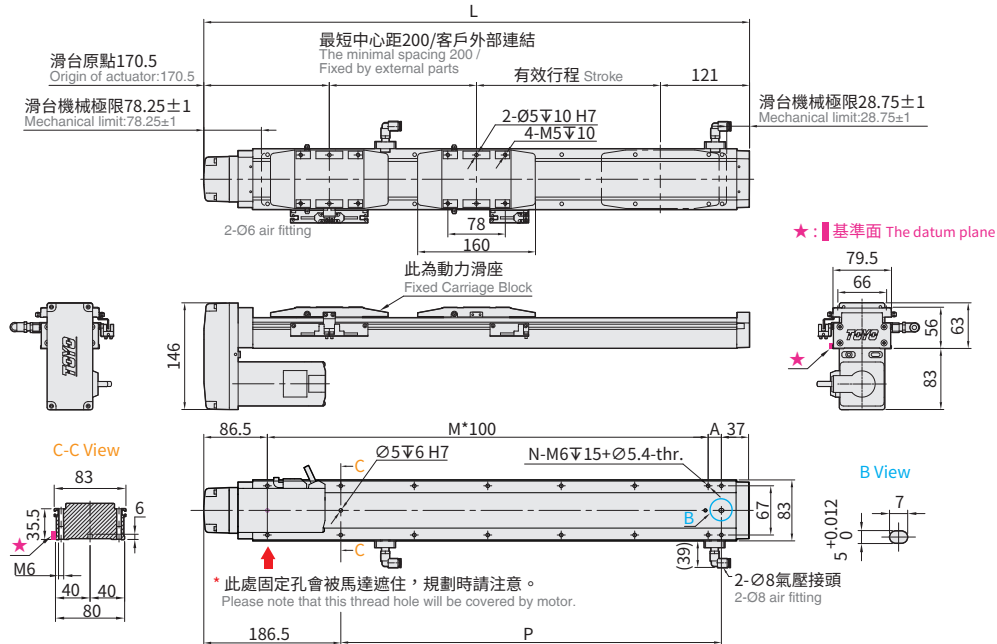

有效行程 Stroke	50 ^{mm}	100	150	200	250	300	350	400	450	500	550	600	650	700	750	800	850	900	950	1000	1050	
極限行程 Limit Stroke (±1)	74.5	124.5	174.5	224.5	274.5	324.5	374.5	424.5	474.5	524.5	574.5	624.5	674.5	724.5	774.5	824.5	874.5	924.5	974.5	1024.5	1074.5	
L	BC	556	606	656	706	756	806	856	906	956	1006	1056	1106	1156	1206	1256	1306	1356	1406	1456	1506	1556
	BM	541.5	591.5	641.5	691.5	741.5	791.5	841.5	891.5	941.5	991.5	1041.5	1091.5	1141.5	1191.5	1241.5	1291.5	1341.5	1391.5	1441.5	1491.5	1541.5
A	18	68	18	68	18	68	18	68	18	68	18	68	18	68	18	68	18	68	18	68	18	68
M	4	4	5	5	6	6	7	7	8	8	9	9	10	10	11	11	12	12	13	13	14	14
N	12	12	14	14	16	16	18	18	20	20	22	22	24	24	26	26	28	28	30	30	32	32
P	318	368	418	468	518	568	618	668	718	768	818	868	918	968	1018	1068	1118	1168	1218	1268	1318	1318
KG	BC	3.93	4.23	4.53	4.82	5.12	5.41	5.71	6.01	6.31	6.6	6.9	7.19	7.49	7.79	8.08	8.38	8.68	8.97	9.27	9.57	9.86
	BM	4.31	4.6	4.9	5.19	5.49	5.79	6.08	6.38	6.68	6.97	7.27	7.57	7.86	8.16	8.45	8.75	9.05	9.34	9.64	9.94	10.23
線速度 Linear Speed mm/s	導程 Lead 6	360																				
	導程 Lead 12	720																				
	導程 Lead 24	1440																				

※1 行程 50 時，因本體上鎖式固定孔會被滑座遮住，僅能使用 4 支螺絲固定，建議客戶本體使用下鎖式固定孔鎖附。When the stroke is 50mm, if fixing the body from the top to the bottom, the fixing hole will be blocked by slider and only can be uses 4 screws to fix,as a result, suggest that fixing actuator body from the bottom to the top.



Download at www.toyorobot.com

BL 馬達左折 Motor Left Side

單位 Unit : mm

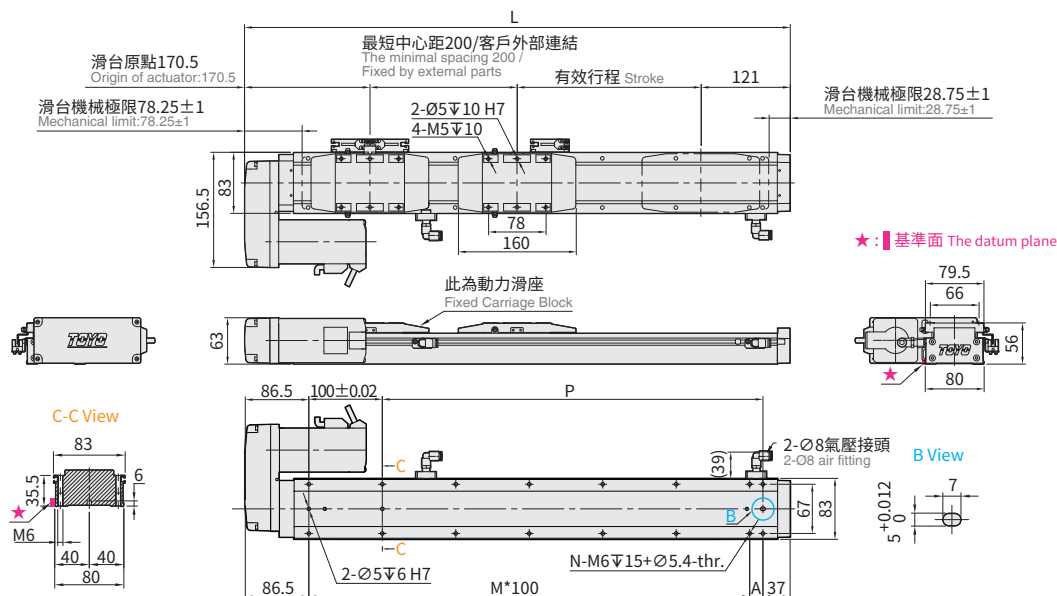

BR 馬達右折 Motor Right Side

單位 Unit : mm

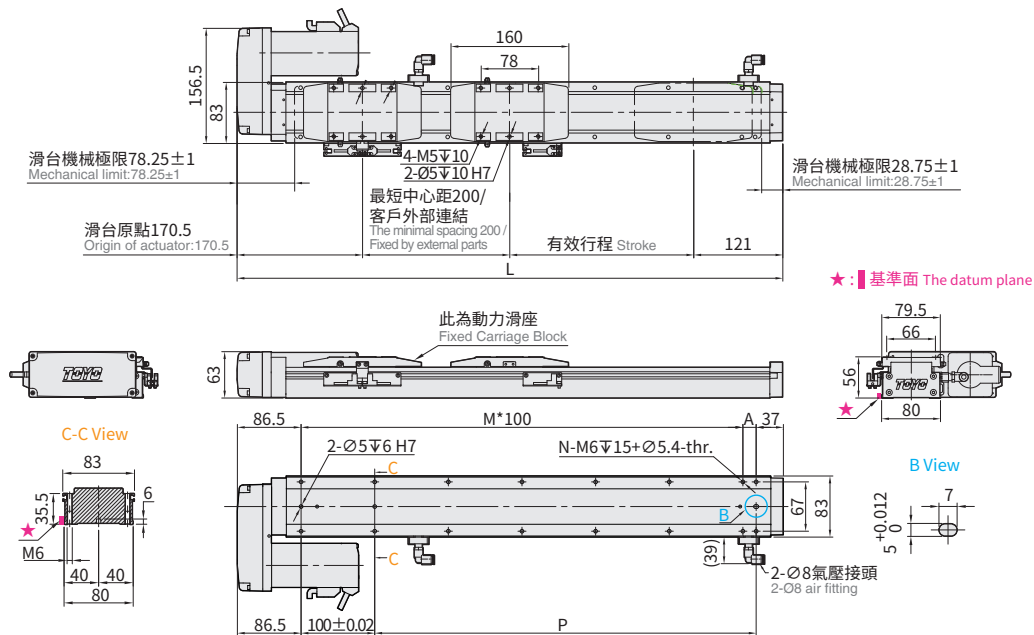

有效行程 Stroke	50 ^{±1}	100	150	200	250	300	350	400	450	500	550	600	650	700	750	800	850	900	950	1000	1050																																												
極限行程 Limit Stroke (±1)	74.5	124.5	174.5	224.5	274.5	324.5	374.5	424.5	474.5	524.5	574.5	624.5	674.5	724.5	774.5	824.5	874.5	924.5	974.5	1024.5	1074.5																																												
L	541.5	591.5	641.5	691.5	741.5	791.5	841.5	891.5	941.5	991.5	1041.5	1091.5	1141.5	1191.5	1241.5	1291.5	1341.5	1391.5	1441.5	1491.5	1541.5																																												
A	18	68	18	68	18	68	18	68	18	68	18	68	18	68	18	68	18	68	18	68	18																																												
M	4	4	5	5	6	6	7	7	8	8	9	10	10	11	11	12	12	12	13	13	14																																												
N	12	12	14	14	16	16	18	18	20	20	22	22	24	24	26	26	28	28	30	30	32																																												
P	318	368	418	468	518	568	618	668	718	768	818	868	918	968	1018	1068	1118	1168	1218	1268	1318																																												
KG	4.31	4.6	4.9	5.19	5.49	5.79	6.08	6.38	6.68	6.97	7.27	7.57	7.86	8.16	8.45	8.75	9.05	9.34	9.64	9.94	10.23																																												
線速度 Linear Speed mm/s	導程 Lead 6					360				350				310				270				240				210				190				170				160				140				130				120				110				100				90			
	導程 Lead 12					720				700				620				540				480				420				380				340				320				280				260				240				220				200				180			
	導程 Lead 24					1440				1400				1240				1080				960				840				760				680				640				560				520				480				440				400				360			

※1 行程 50 時，因本體上鎖式固定孔會被滑座遮住，僅能使用 4 支螺絲固定，建議客戶本體使用下鎖式固定孔鎖附。When the stroke is 50mm, if fixing the body from the top to the bottom, the fixing hole will be blocked by slider and only can be uses 4 screws to fix; as a result, suggest that fixing actuator body from the bottom to the top.

應用例
Application

無塵 / 螺桿仕様
GLCH

一般 / 皮帶仕様
ETB / M

無塵 / 螺桿仕様
GCH / ECH

無塵 / 皮帶仕様
ECB

直交連結
XYGT / XYTH / XYTB

參考資料
Reference

GLCH Series

GLCH5

GLCH8

GLCH12

GLCH5D

GLCH8D

GLCH8D 單軸 /1-axis

▶ 軌道內嵌
Integrated Linear Bearing

▶ 螺桿驅動
Ball Screw Drive

精度
±0.005 mm

Clean Room



最大行程
Maximum Stroke 1050mm

最高速度
Maximum Speed 1440mm/s

馬達容量
Motor Output 400W

最大可搬重量
Max Payload 80kg

型號表示方式 Ordering Method

GLCH8D - L6 - 100 - BC - M40B - C4N5 - 參照右頁 - 0001

本體型號
Model

行程^{*1}
Stroke
50-1050mm
50間隔 50 mm Pitch

選配
Options

特注式樣
Customization Order No.

螺桿導程
Ball Screw Lead

6	6mm
12	12mm
24	24mm

馬達位置
Motor Position

BC	馬達外露 Motor Exposed
BM	馬達下折 Motor Bottom Side
BL	馬達左折 Motor Left Side
BR	馬達右折 Motor Right Side

馬達廠牌、功率
Motor Brand · Power Output

M	三菱 Mitsubishi	05	-	B ^{*2}
P	松下 Panasonic	10	-	
Y	安川 Yaskawa	20	-	
T	台達 Delta	40	400W	

原點感應器
Home Sensor

外掛型 Out Side	
C	馬達側 Motor Side
D	反馬達側 Opposite Motor Side
無 SENSOR No Sensor	
E	無 SENSOR No Sensor

端點極限感應器
Limit Sensor

外掛型 Out Side	
3	1只 1 Pc
4	2只 2 Pcs
6	3只 3 Pcs
7	4只 4 Pcs
8	5只 5 Pcs
9	6只 6 Pcs
無 SENSOR No Sensor	
5	無 SENSOR No Sensor

輸出方式&線長
Output type & Cable length

N5	PNP+5米線 NPN+5M Cable
P2	PNP+2米線 PNP+2M Cable
P5	PNP+5米線 PNP+5M Cable
-	PNP+2米線 NPN+2M Cable

^{*1} 選擇行程50時，光電使用有以下限制：When the stroke is 50mm, the sensor installation has the following restrictions:

馬達方向 BC/BM：1.原點與極限需放置於不同側。2.滑座左右兩側皆需安裝感應片。Motor Direction BC/BM 1.Home sensor and limit sensor has to be installed on the different side of body. 2.Both sides of slider need to install the sensor trigger device.

馬達方向 BL/BR：1.原點+極限感應器最數量最多2只(僅能選用C3/D3/E3/E4/E5)。Motor Direction BL/BR 1.Home + limit sensors is 2 maximum (only C3/D3/E3/E4/E5 can be selected)

^{*2} 馬達若無煞車則不表示。If Motor No Brake, No Description.

基本仕様 Specification

性能	位置重複精度 Repeatability	mm	±0.005			
	螺桿導程 Lead	mm	6	12	24	
	最高轉速 Maximum Rotating speed	rpm	3600	3600	3600	
	最高速度 Maximum linear speed ^{※1}	mm/s	360	720	1440	
	最大可搬重量 ^{※2} Maximum Payload	水平使用 Horizontal	kg	105	85	40
		垂直使用 Vertical	kg	30	20	10
	定格推力 Rated Thrust	N	1156	578	289	
	標準行程 Stroke (increments)	mm	50-1050mm / 50 間隔 (50 increments)			
	最大加速度 Maximum acceleration	G	0.37	0.73	1.47	
	滾珠螺桿 Ball screw	基本動額定負荷 Basic dynamic load rating Ca	N	7733	5855	3007
基本靜額定負荷 Basic static load rating Coa		N	14200	10401	5414	
直線滑軌 Linear Guide	動態水平負載 Dynamic horizontal (100km)	N	18601			
	靜態水平負載 Static Horizontal	N	34189			
固定側軸承 Fixed bearing	基本動額定負荷 Basic dynamic load rating Cr	N	8447			
	靜態容許負荷 Static load rating Cor	N	5060			
部品	AC 伺服馬達容量 AC Servo Motor Output	W	400			
	滾珠螺桿外徑 Ball Screw Ø	mm	C7Ø14			
	連軸器 Coupling	mm	10X14			
	原點感應器 Home Sensor	外掛 Outside	T64N2 (NPN+2 米線) (NPN+2M Cable)			

※1 長行程時，會產生螺桿偏擺，需將速度調降 (線速度請參閱尺寸下方表格)

During in a long stroke, it causes ballscrew deflection, the speed must reduce. (Please refer to the linear velocity from the data sheet below the dimension graph.)

※2 由於各廠牌的馬達性能不同，需適度搭配回升電阻以達到此荷重條件。

Since the motor performance of each brand is different, a regenerative resistor needs to be appropriately matched to achieve this load condition.

容許負載力距表 Allowable Overhang

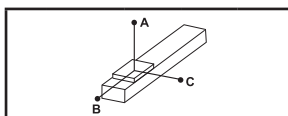

(單位 Unit: mm)

水平安裝 Horizontal Installation		A	B	C
導程 6 Lead	30kg	1900	165	261
	50kg	1080	88	140
	105kg	434	29	47
導程 12 Lead	25kg	780	175	240
	35kg	530	117	160
	85kg	175	33	46
導程 24 Lead	4kg	1400	820	750
	12kg	440	257	235
	40kg	109	60	55

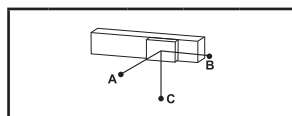

(單位 Unit: mm)

壁掛安裝 Wall Installation		A	B	C
導程 6 Lead	30kg	261	165	1900
	50kg	140	88	1080
	105kg	47	29	434
導程 12 Lead	25kg	240	175	780
	35kg	160	117	530
	85kg	46	33	175
導程 24 Lead	4kg	750	820	1400
	12kg	235	257	440
	40kg	55	60	109

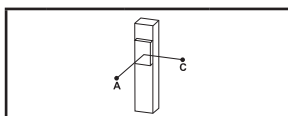

(單位 Unit: mm)

垂直安裝 Vertical Installation		A	C
導程 6 Lead	6kg	335	335
	30kg	180	180
	-	-	-
導程 12 Lead	12kg	400	400
	20kg	240	240
	-	-	-
導程 24 Lead	6kg	460	460
	10kg	275	275
	-	-	-

靜額定扭矩 Static Loading Moment

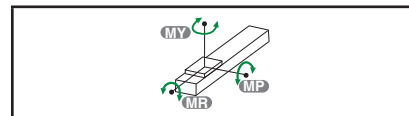

(單位 Unit: N.m)

MY	137
MP	137
MR	227

* 力矩表所表示的數據，代表荷重的重心位置於單一方向容許懸出的長度。
The data represented by the moment table is the center of gravity of the load. The length of the overhang is allowed in a single direction.
* 符合型錄規範的正常情況下，保證壽命為 10000 公里。
Operation life is 10,000km when the product is using under the specified conditions.
* 倒吊使用無法套用標準規範，如有需求請洽詢我司業務。
Data information is not for ceiling-mount inverse use. Contact us for the details if you want to apply ceiling-mount inverse usage.
* 壽命及力矩是以馬達加減速設定 0.2 秒計算。
The life and torque are calculated by setting the motor acceleration and deceleration for 0.2 seconds.

選配 Options

MM

指定馬達出線方向 Selectable Cable Leading Direction		
代號 Code	說明 Instructions	需參照 Refer to
MW	朝上 Upper side	P.111 ~ P.112
MM	朝下 Bottom side	
ML	朝左 Left side	
MR	朝右 Right side	

CMK

馬達傳動配件追加鍵槽 Additional keyway for motor drive parts				
代號 Code	說明 Instructions			需參照 Refer to
	追加鍵槽 Keyway Groove	馬達位置 Motor Position	出貨型式 Shipment Type	
CMK	單邊 (限定馬達側) Single (Limited to the motor side)	BC	鍵槽式聯軸器 Keyway Coupling	P.113 ~ P.115
		BL/BR/BM	鍵槽式皮帶輪 Keyway Belt Pulley	
SKY	雙邊 Double	BC	鍵槽式聯軸器 Keyway Coupling	
		BL/BR/BM	鍵槽式皮帶輪 Keyway Belt Pulley	
SKN	雙邊 Double	BC	無聯軸器 (請自行購買安裝) Without Coupling (Please purchase and install by yourself)	
		BL/BR/BM	無馬達端皮帶輪 (請自行購買安裝) Without Belt Pulley (Please purchase and install by yourself)	



Download at www.toyorobot.com

BC 馬達外露 Motor Exposed

單位 Unit : mm

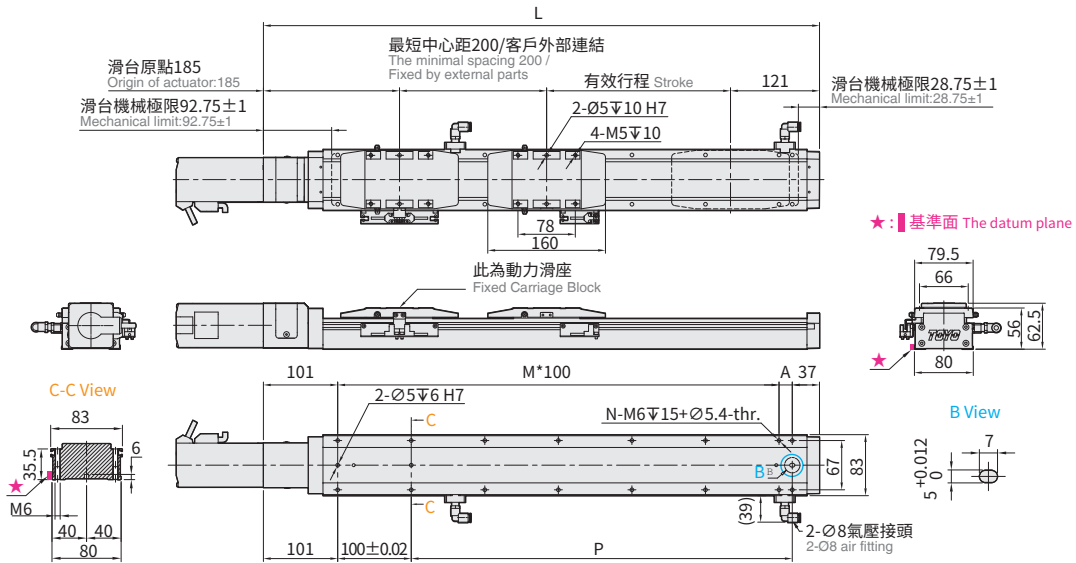

BM 馬達下折 Motor Bottom Side

單位 Unit : mm

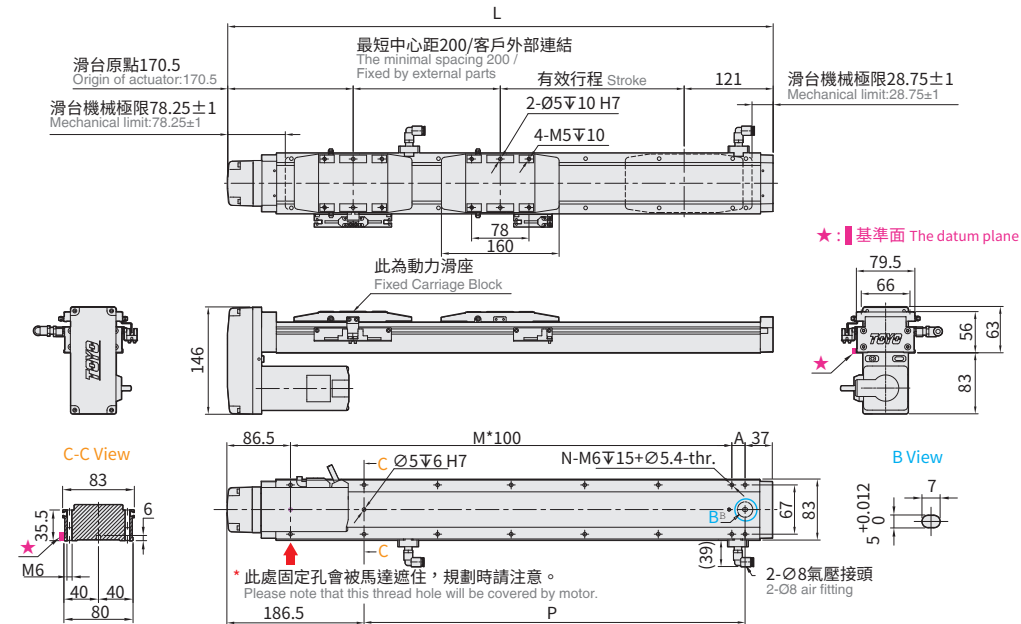

有效行程 Stroke	50 ^{mm}	100	150	200	250	300	350	400	450	500	550	600	650	700	750	800	850	900	950	1000	1050	
極限行程 Limit Stroke (±1)	74.5	124.5	174.5	224.5	274.5	324.5	374.5	424.5	474.5	524.5	574.5	624.5	674.5	724.5	774.5	824.5	874.5	924.5	974.5	1024.5	1074.5	
L	BC	556	606	656	706	756	806	856	906	956	1006	1056	1106	1156	1206	1256	1306	1356	1406	1456	1506	1556
	BM	541.5	591.5	641.5	691.5	741.5	791.5	841.5	891.5	941.5	991.5	1041.5	1091.5	1141.5	1191.5	1241.5	1291.5	1341.5	1391.5	1441.5	1491.5	1541.5
A	18	68	18	68	18	68	18	68	18	68	18	68	18	68	18	68	18	68	18	68	18	68
M	4	4	5	5	6	6	7	7	8	8	9	9	10	10	11	11	12	12	13	13	14	14
N	12	12	14	14	16	16	18	18	20	20	22	22	24	24	26	26	28	28	30	30	32	32
P	318	368	418	468	518	568	618	668	718	768	818	868	918	968	1018	1068	1118	1168	1218	1268	1318	1318
KG	BC	3.93	4.23	4.53	4.82	5.12	5.41	5.71	6.01	6.31	6.6	6.9	7.19	7.49	7.79	8.08	8.38	8.68	8.97	9.27	9.57	9.86
	BM	4.31	4.6	4.9	5.19	5.49	5.79	6.08	6.38	6.68	6.97	7.27	7.57	7.86	8.16	8.45	8.75	9.05	9.34	9.64	9.94	10.23
線速度 Linear Speed mm/s	導程 Lead 6	360				350				310	270	240	210	190	170	160	140	130	120	110	100	90
	導程 Lead 12	720				700				620	540	480	420	380	340	320	280	260	240	220	200	180
	導程 Lead 24	1440				1400				1240	1080	960	840	760	680	640	560	520	480	440	400	360

※1 行程 50 時，因本體上鎖式固定孔會被滑座遮住，僅能使用 4 支螺絲固定，建議客戶本體使用下鎖式固定孔鎖附。When the stroke is 50mm, if fixing the body from the top to the bottom, the fixing hole will be blocked by slider and only can be uses 4 screws to fix.as a result, suggest that fixing actuator body from the bottom to the top.



Download at www.toyorobot.com

BL 馬達左折 Motor Left Side

單位 Unit : mm

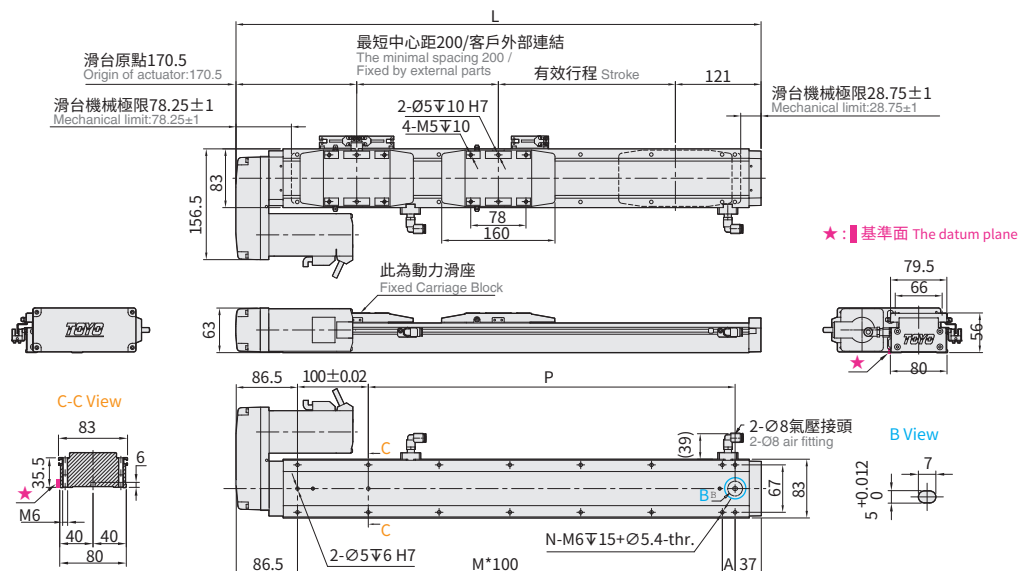

BR 馬達右折 Motor Right Side

單位 Unit : mm

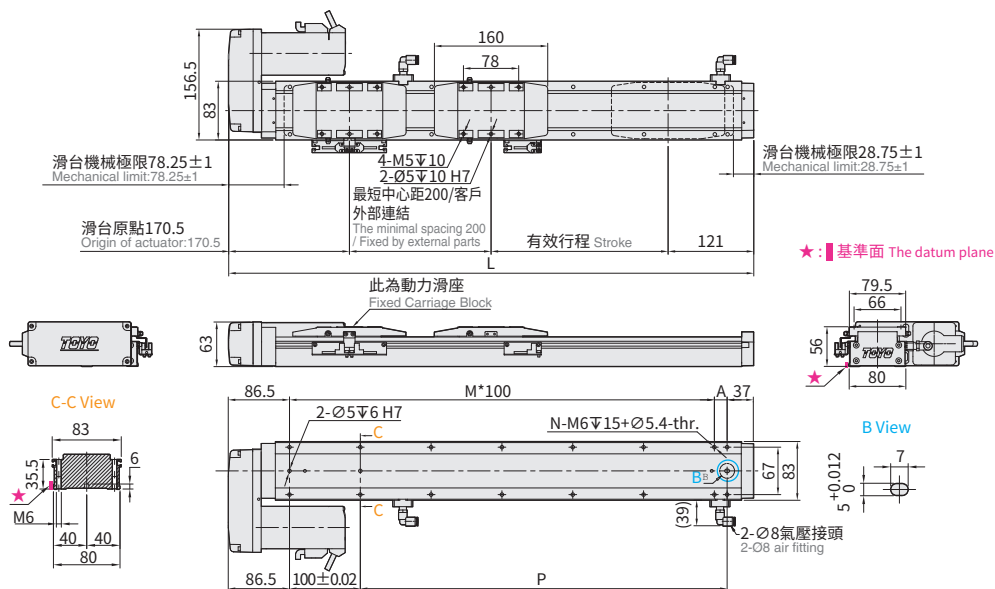

有效行程 Stroke	50 ^{±1}	100	150	200	250	300	350	400	450	500	550	600	650	700	750	800	850	900	950	1000	1050	
極限行程 Limit Stroke (±1)	74.5	124.5	174.5	224.5	274.5	324.5	374.5	424.5	474.5	524.5	574.5	624.5	674.5	724.5	774.5	824.5	874.5	924.5	974.5	1024.5	1074.5	
L	541.5	591.5	641.5	691.5	741.5	791.5	841.5	891.5	941.5	991.5	1041.5	1091.5	1141.5	1191.5	1241.5	1291.5	1341.5	1391.5	1441.5	1491.5	1541.5	
A	18	68	18	68	18	68	18	68	18	68	18	68	18	68	18	68	18	68	18	68	18	
M	4	4	5	5	6	6	7	7	8	8	9	10	10	11	11	12	12	13	13	14	14	
N	12	12	14	14	16	16	18	18	20	20	22	22	24	24	26	26	28	28	30	30	32	
P	318	368	418	468	518	568	618	668	718	768	818	868	918	968	1018	1068	1118	1168	1218	1268	1318	
KG	4.31	4.6	4.9	5.19	5.49	5.79	6.08	6.38	6.68	6.97	7.27	7.57	7.86	8.16	8.45	8.75	9.05	9.34	9.64	9.94	10.23	
線速度 Linear Speed mm/s	導程 Lead 6	360				350				310	270	240	210	190	170	160	140	130	120	110	100	90
	導程 Lead 12	720				700				620	540	480	420	380	340	320	280	260	240	220	200	180
	導程 Lead 24	1440				1400				1240	1080	960	840	760	680	640	560	520	480	440	400	360

※1 行程 50 時，因本體上鎖式固定孔會被滑座遮住，僅能使用 4 支螺絲固定，建議客戶本體使用下鎖式固定孔鎖附。When the stroke is 50mm, if fixing the body from the top to the bottom, the fixing hole will be blocked by slider and only can be uses 4 screws to fix; as a result, suggest that fixing actuator body from the bottom to the top.

應用例
Application

無塵 / 螺桿仕様
GLCH

一般 / 皮帶仕様
ETB / M

無塵 / 螺桿仕様
GCH / ECH

無塵 / 皮帶仕様
ECB

直交連結
XYGT / XYTH / XYTB

參考資料
Reference

GLCH Series

GLCH5

GLCH8

GLCH12

GLCH5D

GLCH8D

GLCB5 單軸 / 1-axis

▶ 軌道內嵌
Integrated Linear Bearing

▶ 皮帶驅動
Belt Driver

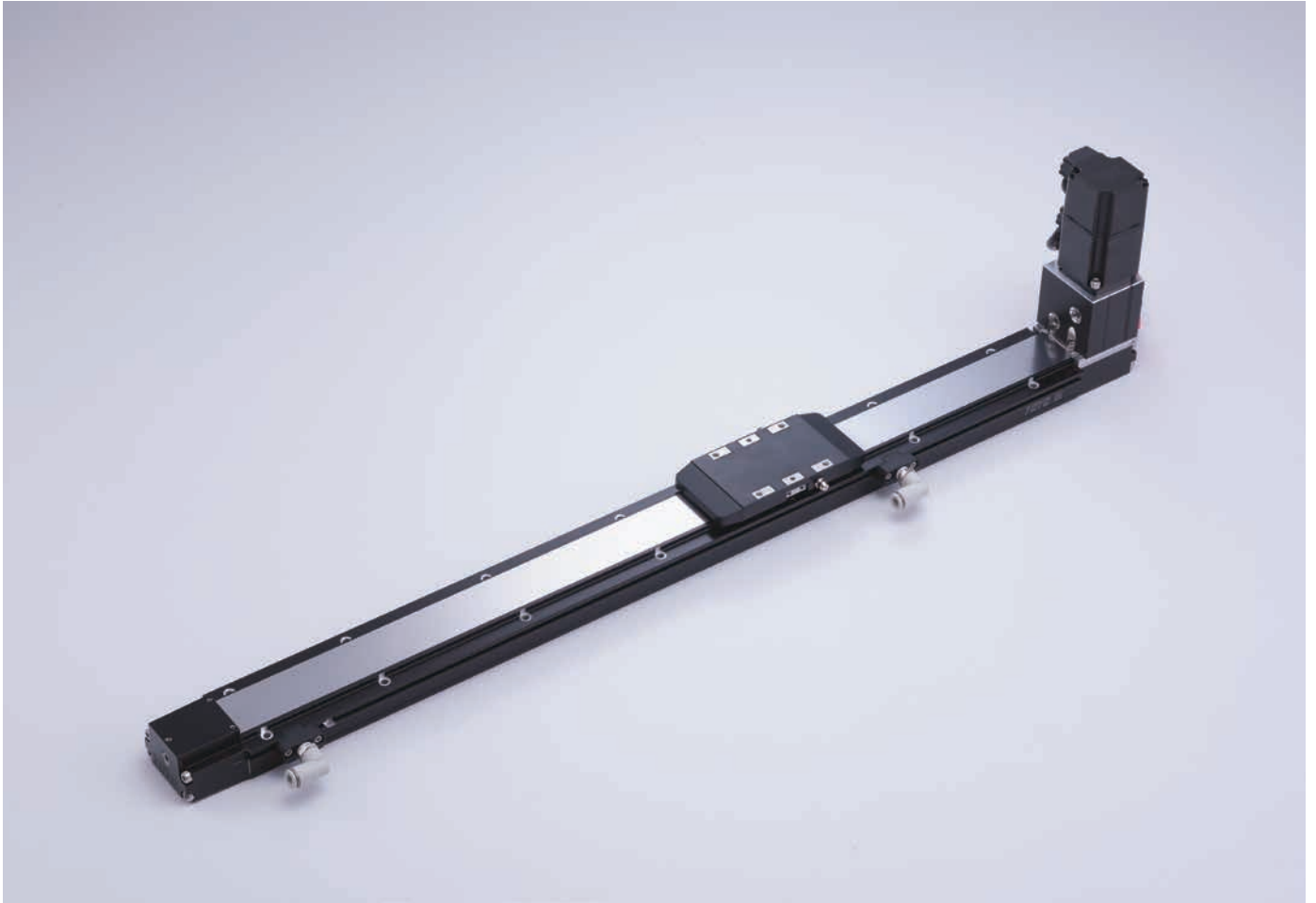

最大行程
Maximum Stroke **3000mm**

最高速度
Maximum Speed **1067mm/s**

馬達容量
Motor Output **100W**

最大可搬重量
Max Payload **5kg**

型號表示方式 Ordering Method

GLCB5 - X32 - 500 - BM - M10 - C4N5 - 參照右頁
Refer to the right page. - 0001

本體型號
Model

導程
Lead

32 32mm

行程^{*1}
Stroke

50-3000mm
50間隔 50 mm Pitch

選配
Options

特注式樣
Customization Order No.

皮帶型式
Belt Type

X 橡膠皮帶
Rubber belt

馬達位置
Motor Position

BW 馬達上折
Motor Top Side
BM 馬達下折
Motor Bottom Side

馬達廠牌、功率
Motor Brand、Power Output

M	三菱 Mitsubishi	05	-
P	松下 Panasonic	10	100W
Y	安川 Yaskawa	20	-
T	台達 Delta	40	-

原點感應器
Home Sensor

外掛型 Out Side	
C	馬達側 Motor Side
D	反馬達側 Opposite Motor Side
無 SENSOR No Sensor	
E	無 SENSOR No Sensor

端點極限感應器
Limit Sensor

外掛型 Out Side	
3	1只 1 Pc
4	2只 2 Pcs
6	3只 3 Pcs
7	4只 4 Pcs
8	5只 5 Pcs
9	6只 6 Pcs
無 SENSOR No Sensor	
5	無 SENSOR No Sensor

輸出方式&線長
Output type & Cable length

N5	NPN+5米線 NPN+5M Cable
P2	PNP+2米線 PNP+2M Cable
P5	PNP+5米線 PNP+5M Cable
-	NPN+2米線 NPN+2M Cable

*1 選擇行程50時, 光電使用有以下限制: When the stroke is 50mm, the sensor installation has the following restrictions:

1. 原點與極限需放置於不同側。2. 滑座左右兩側皆需安裝感應片。Motor Direction BC/BM 1.Home sensor and limit sensor has to be installed on the different side of body. 2.Both sides of slider need to install the sensor trigger device.

基本仕様 Specification

性能	位置重複精度 Repeatability	mm	±0.06	
	導程 Lead	mm	32	
	最高轉速 Maximum Rotating speed	rpm	2000	
	最高速度 Maximum linear speed	mm/s	1067	
	最大可搬重量 Maximum Payload	水平使用 Horizontal	kg	5
		垂直使用 Vertical	kg	
	定格推力 Rated Thrust	N	53	
	標準行程 Stroke (increments)	mm	50-3000mm / 50 間隔 (50 increments)	
最大加速度 Maximum acceleration	G	0.27		
部品	AC 伺服馬達容量 AC Servo Motor Output	W	100	
	皮帶寬度 Belt Width	mm	9	
	原點感應器 Home Sensor	外掛 Outside	T64N2 (NPN+2 米線) (NPN+2M Cable)	

容許負載力距表 Allowable Overhang

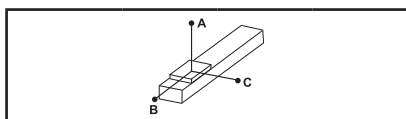

(單位 Unit: mm)

水平安裝 Horizontal Installation	A	B	C
2kg	622	64	65
3kg	380	36	38
5kg	168	14	15

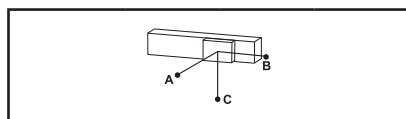

(單位 Unit: mm)

壁掛安裝 Wall Installation	A	B	C
2kg	65	64	622
3kg	38	36	380
5kg	15	14	168

靜額定扭矩 Static Loading Moment

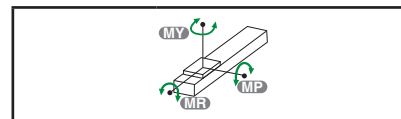

(單位 Unit: N.m)

MY	73
MP	73
MR	115

* 力矩表所表示的數據，代表荷重的重心位置於單一方向容許懸出的長度。
The data represented by the moment table is the center of gravity of the load. The length of the overhang is allowed in a single direction.
* 符合型錄規範的正常使用下，保證壽命為 10000 公里。
Operation life is 10,000km when the product is using under the specified conditions.
* 倒吊使用無法套用標準規範，如有需求請洽詢我司業務。
Data information is not for ceiling-mount inverse use. Contact us for the details if you want to apply ceiling-mount inverse usage.
* 壽命及力矩是以馬達加減速設定 0.4 秒計算。
The life and torque are calculated by setting the motor acceleration and deceleration for 0.4 seconds.

選配 Options

MM

指定馬達出線方向 Selectable Cable Leading Direction		
代號 Code	說明 Instructions	需參照 Refer to
MW	朝上 Upper side	P.111 ~ P.112
MM	朝下 Bottom side	
ML	朝左 Left side	
MR	朝右 Right side	

CMK

馬達傳動配件追加鍵槽 Additional keyway for motor drive parts			
代號 Code	說明 Instructions		需參照 Refer to
	追加鍵槽 Keyway Groove	出貨型式 Shipment Type	
CMK	單邊 (限定馬達側) Single (Limited to the motor side)	鍵槽式皮帶輪 Keyway Belt Pulley	P.113 ~ P.115



Download at www.toyorobot.com

BW 馬達上折 Motor Top Side

單位 Unit : mm

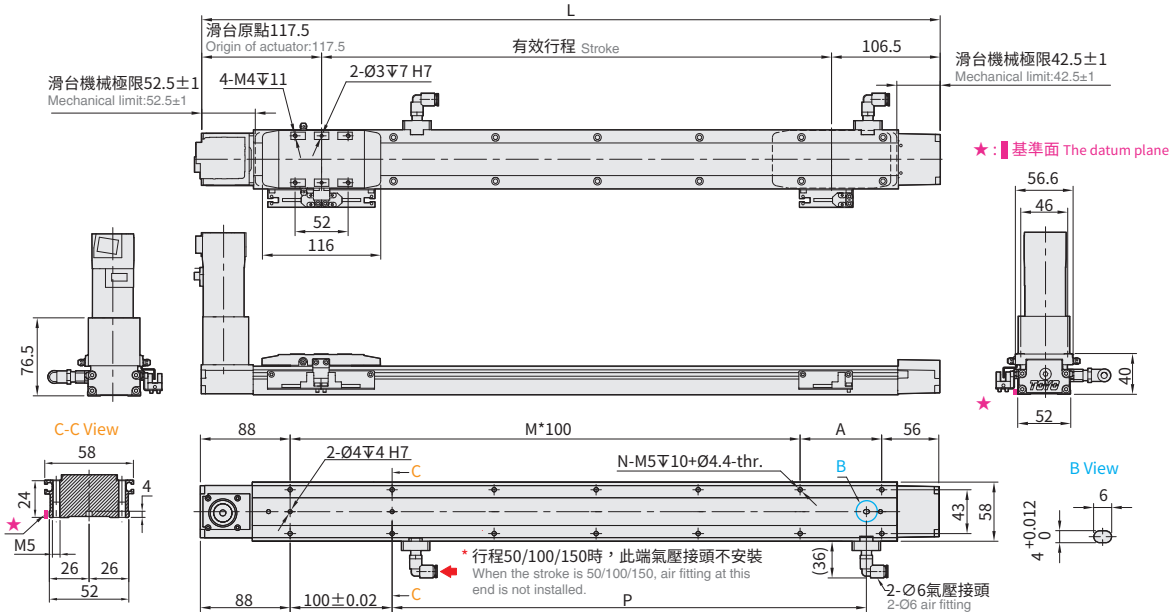

BM 馬達下折 Motor Bottom Side

單位 Unit : mm

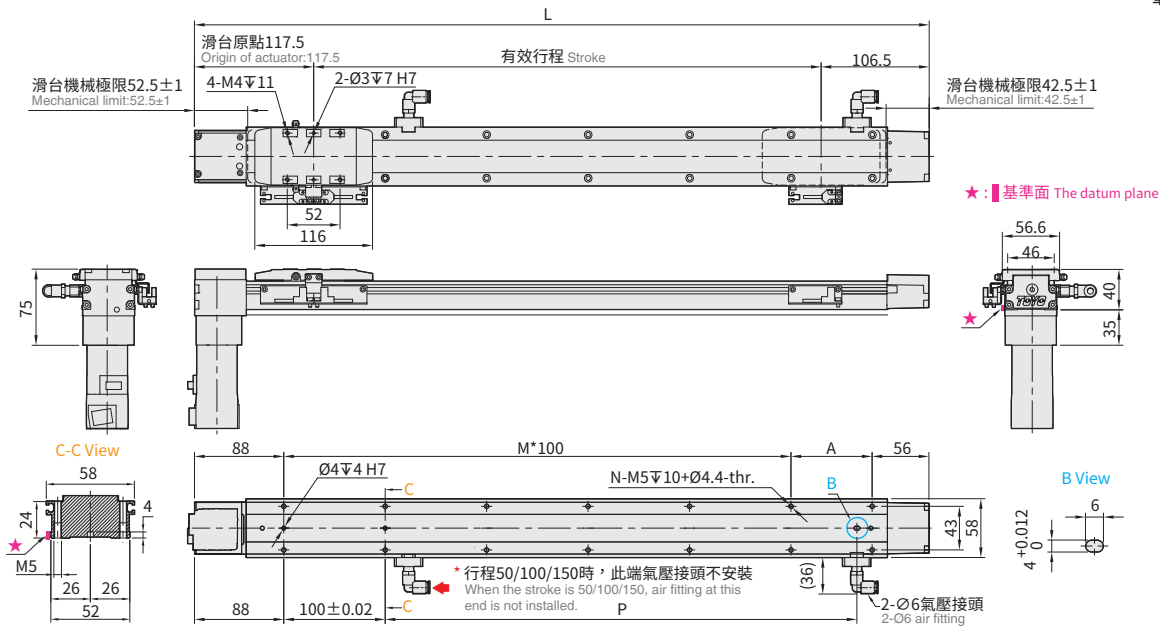

有效行程 Stroke	50	100	150	200	250	300	350	400	450	500	550	600	650	700	750	800	850	900	950	1000	1050	1100	1150	1200	1250	1300	1350	1400	1450	1500			
極限行程 Limit Stroke (±1)	63	113	163	213	263	313	363	413	463	513	563	613	663	713	763	813	863	913	963	1013	1063	1113	1163	1213	1263	1313	1363	1413	1463	1513			
L	274	324	374	424	474	524	574	624	674	724	774	824	874	924	974	1024	1074	1124	1174	1224	1274	1324	1374	1424	1474	1524	1574	1624	1674	1724			
A	30	80	30	80	30	80	30	80	30	80	30	80	30	80	30	80	30	80	30	80	30	80	30	80	30	80	30	80	30	80			
M	1	1	2	2	3	3	4	4	5	5	6	6	7	7	8	8	9	9	10	10	11	11	12	12	13	13	14	14	15	15			
N	6	6	8	8	10	10	12	12	14	14	16	16	18	18	20	20	22	22	24	24	26	26	28	28	30	30	32	32	34	34			
P	15	65	115	165	215	265	315	365	415	465	515	565	615	665	715	765	815	865	915	965	1015	1065	1115	1165	1215	1265	1315	1365	1415	1465			
KG	1.6	1.64	1.68	1.72	1.76	1.8	1.84	1.88	1.92	1.96	1.99	2.03	2.07	2.11	2.15	2.18	2.22	2.26	2.3	2.33	2.37	2.41	2.45	2.48	2.52	2.56	2.6	2.63	2.67	2.71			
線速度 Linear Speed mm/s	1067																																
有效行程 Stroke	1550	1600	1650	1700	1750	1800	1850	1900	1950	2000	2050	2100	2150	2200	2250	2300	2350	2400	2450	2500	2550	2600	2650	2700	2750	2800	2850	2900	2950	3000			
極限行程 Limit Stroke (±1)	1563	1613	1663	1713	1763	1813	1863	1913	1963	2013	2063	2113	2163	2213	2263	2313	2363	2413	2463	2513	2563	2613	2663	2713	2763	2813	2863	2913	2963	3013			
L	1774	1824	1874	1924	1974	2024	2074	2124	2174	2224	2274	2324	2374	2424	2474	2524	2574	2624	2674	2724	2774	2824	2874	2924	2974	3024	3074	3124	3174	3224			
A	30	80	30	80	30	80	30	80	30	80	30	80	30	80	30	80	30	80	30	80	30	80	30	80	30	80	30	80	30	80			
M	16	16	17	17	18	18	19	19	20	20	21	21	22	22	23	23	24	24	25	25	26	26	27	27	28	28	29	29	30	30			
N	36	36	38	38	40	40	42	42	44	44	46	46	48	48	50	50	52	52	54	54	56	56	58	58	60	60	62	62	64	64			
P	1515	1565	1615	1665	1715	1765	1815	1865	1915	1965	2015	2065	2115	2165	2215	2265	2315	2365	2415	2465	2515	2565	2615	2665	2715	2765	2815	2865	2915	2965			
KG	2.75	2.78	2.81	2.85	2.89	2.93	2.97	3	3.04	3.08	3.12	3.15	3.19	3.23	3.27	3.3	3.34	3.38	3.42	3.45	3.49	3.53	3.57	3.6	3.64	3.67	3.71	3.75	3.79	3.82			
線速度 Linear Speed mm/s	1067																																

免費服務專線：台灣 0800-800-893
Toll-Free Number Taiwan

Memo

應用例
Application

一般 / 螺桿仕様
GTH / GTY / ETH / Y

無塵 / 皮帶仕様
GLCB

無塵 / 螺桿仕様
GCH / ECH

無塵 / 皮帶仕様
ECB

直交連結
XYGT / XTH / XYTB

參考資料
Reference

GLCB Series

GLCB5

GLCB8

GLCB8 單軸 / 1-axis

▶ 軌道內嵌
Integrated Linear Bearing

▶ 皮帶驅動
Belt Driver



最大行程
Maximum Stroke **3000mm**

最高速度
Maximum Speed **2000mm/s**

馬達容量
Motor Output **400W**

最大可搬重量
Max Payload **8kg**

型號表示方式 Ordering Method

GLCB8 - X60 - 500 - BM - M40 - C4N5 - 參照右頁
Refer to the right page. - 0001

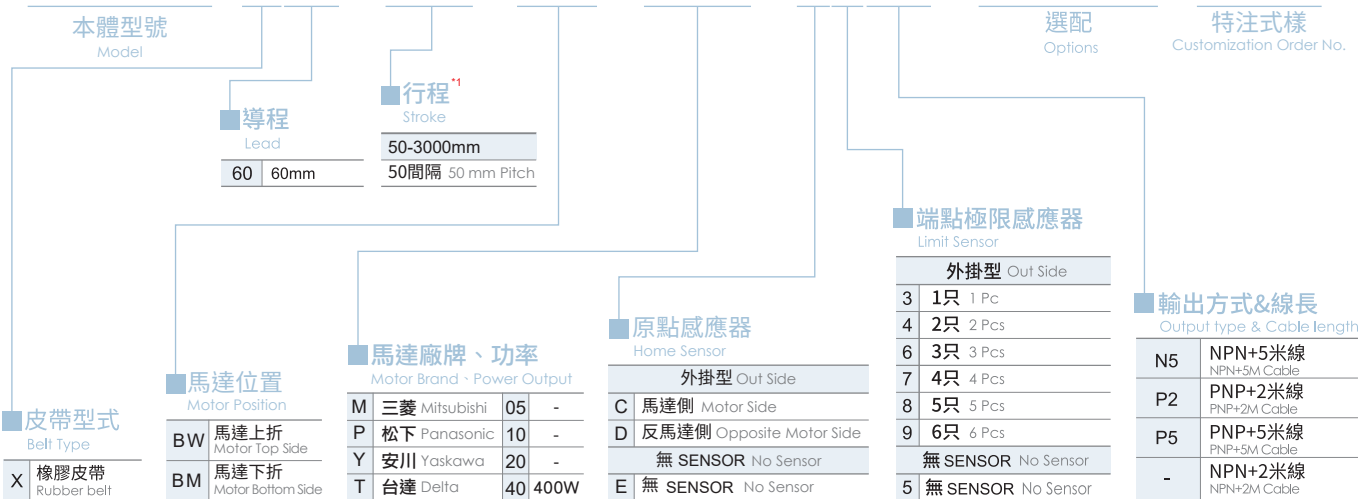

*1 選擇行程50時, 光電使用有以下限制: When the stroke is 50mm, the sensor installation has the following restrictions:
1. 原點與極限需放置於不同側。2. 滑座左右兩側皆需安裝感應片。Motor Direction BC/BM 1.Home sensor and limit sensor has to be installed on the different side of body. 2.Both sides of slider need to install the sensor trigger device.

基本仕様 Specification

性能	位置重複精度 Repeatability		mm	±0.06
	導程 Lead		mm	60
	最高轉速 Maximum Rotating speed		rpm	2000
	最高速度 Maximum linear speed		mm/s	2000
	最大可搬重量 Maximum Payload	水平使用 Horizontal	kg	8
		垂直使用 Vertical	kg	
	定格推力 Rated Thrust		N	116
	標準行程 Stroke (increments)		mm	50-3000mm / 50 間隔 (50 increments)
	最大加速度 Maximum acceleration		G	0.51
部品	AC 伺服馬達容量 AC Servo Motor Output		W	400
	皮帶寬度 Belt Width		mm	8
	原點感應器 Home Sensor	外掛 Outside		T64N2 (NPN+2 米線) (NPN+2M Cable)

容許負載力距表 Allowable Overhang

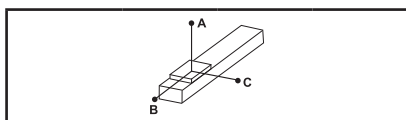

(單位 Unit: mm)

水平安裝 Horizontal Installation	A	B	C
2kg	1110	126	132
5kg	427	90	94
8kg	256	73	77

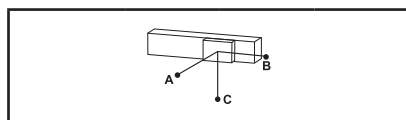

(單位 Unit: mm)

壁掛安裝 Wall Installation	A	B	C
2kg	132	126	1110
5kg	94	90	427
8kg	77	73	256

靜額定扭矩 Static Loading Moment

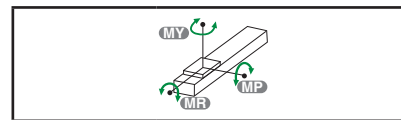

(單位 Unit: N.m)

MY	137
MP	137
MR	227

* 力矩表所表示的數據，代表荷重的重心位置於單一方向容許懸出的長度。
The data represented by the moment table is the center of gravity of the load. The length of the overhang is allowed in a single direction.
* 符合型錄規範的正常使用下，保證壽命為 10000 公里。
Operation life is 10,000km when the product is using under the specified conditions.
* 倒吊使用無法套用標準規範，如有需求請洽詢我司業務。
Data information is not for ceiling-mount inverse use. Contact us for the details if you want to apply ceiling-mount inverse usage.
* 壽命及力矩是以馬達加速減速設定 0.4 秒計算。
The life and torque are calculated by setting the motor acceleration and deceleration for 0.4 seconds.

選配 Options

MM

指定馬達出線方向 Selectable Cable Leading Direction		
代號 Code	說明 Instructions	需參照 Refer to
MW	朝上 Upper side	P.111 ~ P.112
MM	朝下 Bottom side	
ML	朝左 Left side	
MR	朝右 Right side	

CMK

馬達傳動配件追加鍵槽 Additional keyway for motor drive parts			
代號 Code	說明 Instructions		需參照 Refer to
	追加鍵槽 Keyway Groove	出貨型式 Shipment Type	
CMK	單邊 (限定馬達側) Single (Limited to the motor side)	鍵槽式皮帶輪 Keyway Belt Pulley	P.113 ~ P.115

GLCB8 單軸 / 1-axis

▶ 軌道內嵌
Integrated Linear Bearing

▶ 皮帶驅動
Belt Driver



Download at www.toyorobot.com

BW 馬達上折 Motor Top Side

單位 Unit : mm

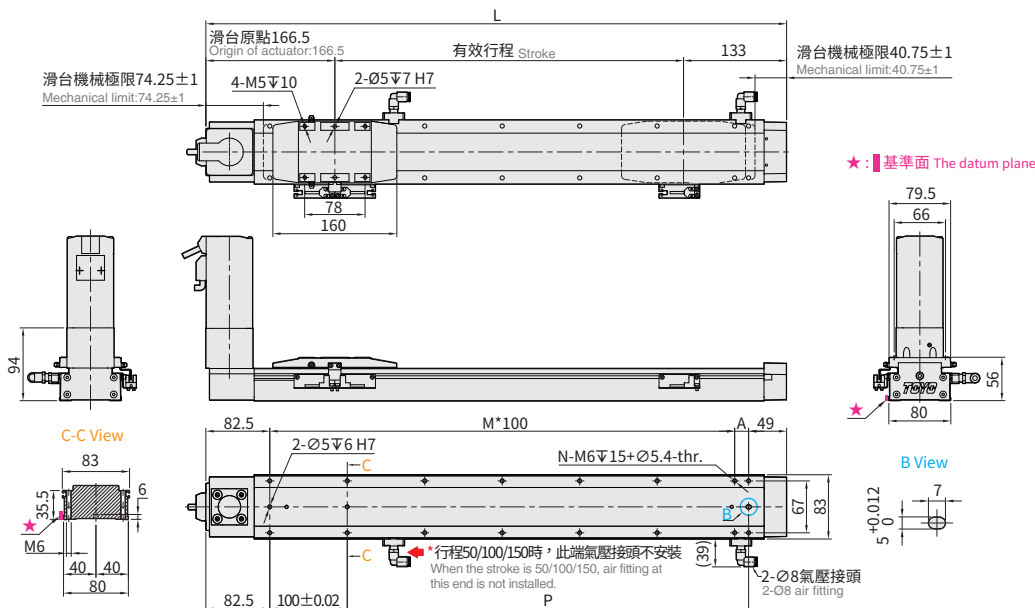

BM 馬達下折 Motor Bottom Side

單位 Unit : mm

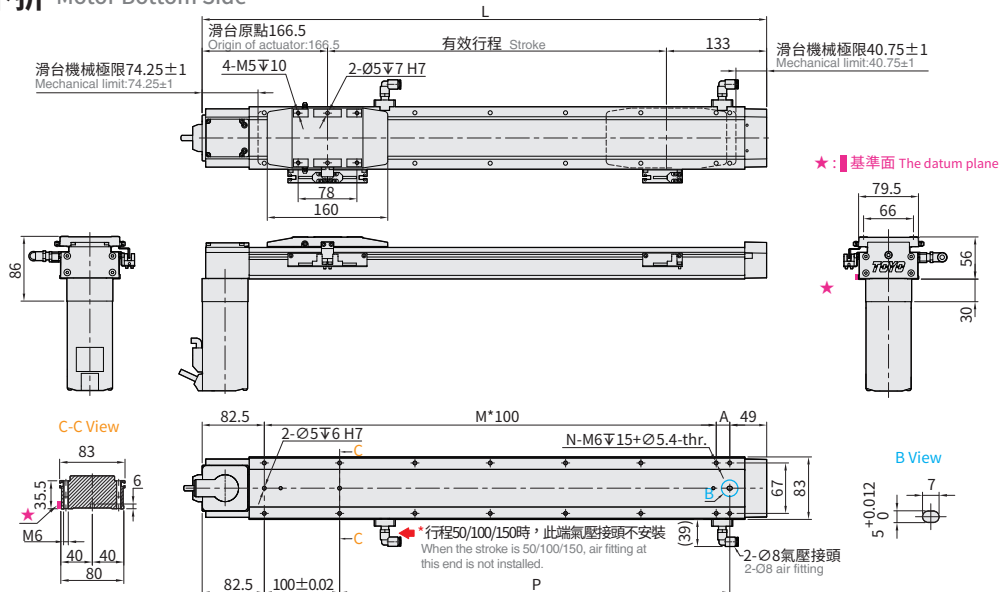

有效行程 Stroke	50	100	150	200	250	300	350	400	450	500	550	600	650	700	750	800	850	900	950	1000	1050	1100	1150	1200	1250	1300	1350	1400	1450	1500		
極限行程 Limit Stroke (±1)	74.5	124.5	174.5	224.5	274.5	324.5	374.5	424.5	474.5	524.5	574.5	624.5	674.5	724.5	774.5	824.5	874.5	924.5	974.5	1024.5	1074.5	1124.5	1174.5	1224.5	1274.5	1324.5	1374.5	1424.5	1474.5	1524.5		
L	349.5	399.5	449.5	499.5	549.5	599.5	649.5	699.5	749.5	799.5	849.5	899.5	949.5	999.5	1049.5	1099.5	1149.5	1199.5	1249.5	1299.5	1349.5	1399.5	1449.5	1499.5	1549.5	1599.5	1649.5	1699.5	1749.5	1799.5		
A	18	68	18	68	18	68	18	68	18	68	18	68	18	68	18	68	18	68	18	68	18	68	18	68	18	68	18	68	18	68		
M	2	2	3	3	4	4	5	5	6	6	7	7	8	8	9	9	10	10	11	11	12	12	13	13	14	14	15	15	16	16		
N	8	8	10	10	12	12	14	14	16	16	18	18	20	20	22	22	24	24	26	26	28	28	30	30	32	32	34	34	36	36		
P	118	168	218	268	318	368	418	468	518	568	618	668	718	768	818	868	918	968	1018	1068	1118	1168	1218	1268	1318	1368	1418	1468	1518	1568		
KG	2.56	2.77	2.98	3.19	3.4	3.61	3.82	4.03	4.24	4.45	4.66	4.87	5.08	5.29	5.5	5.71	5.92	6.13	6.34	6.55	6.76	6.97	7.18	7.39	7.6	7.81	8.02	8.23	8.44	8.65		
線速度 Linear Speed mm/s	2000																															
有效行程 Stroke	1550	1600	1650	1700	1750	1800	1850	1900	1950	2000	2050	2100	2150	2200	2250	2300	2350	2400	2450	2500	2550	2600	2650	2700	2750	2800	2850	2900	2950	3000		
極限行程 Limit Stroke (±1)	1574.5	1624.5	1674.5	1724.5	1774.5	1824.5	1874.5	1924.5	1974.5	2024.5	2074.5	2124.5	2174.5	2224.5	2274.5	2324.5	2374.5	2424.5	2474.5	2524.5	2574.5	2624.5	2674.5	2724.5	2774.5	2824.5	2874.5	2924.5	2974.5	3024.5		
L	1849.5	1899.5	1949.5	1999.5	2049.5	2099.5	2149.5	2199.5	2249.5	2299.5	2349.5	2399.5	2449.5	2499.5	2549.5	2599.5	2649.5	2699.5	2749.5	2799.5	2849.5	2899.5	2949.5	2999.5	3049.5	3099.5	3149.5	3199.5	3249.5	3299.5		
A	18	68	18	68	18	68	18	68	18	68	18	68	18	68	18	68	18	68	18	68	18	68	18	68	18	68	18	68	18	68		
M	17	17	18	18	19	19	20	20	21	21	22	22	23	23	24	24	25	25	26	26	27	27	28	28	29	29	30	30	31	31		
N	38	38	40	40	42	42	44	44	46	46	48	48	50	50	52	52	54	54	56	56	58	58	60	60	62	62	64	64	66	66		
P	1618	1668	1718	1768	1818	1868	1918	1968	2018	2068	2118	2168	2218	2268	2318	2368	2418	2468	2518	2568	2618	2668	2718	2768	2818	2868	2918	2968	3018	3068		
KG	8.86	9.07	9.28	9.49	9.7	9.91	10.12	10.33	10.54	10.75	10.96	11.17	11.38	11.59	11.8	12.01	12.22	12.43	12.64	12.85	13.06	13.27	13.48	13.69	13.9	14.11	14.32	14.53	14.74	14.95		
線速度 Linear Speed mm/s	2000																															

免費服務專線：台灣 **0800-800-893**
Toll-Free Number Taiwan

Memo

應用例
Application

一般 / 螺桿仕様
GTH / GTY / ETH / Y

無塵 / 皮帶仕様
GLCB

無塵 / 螺桿仕様
GCH / ECH

無塵 / 皮帶仕様
ECB

直交連結
XYGT / XTH / XYTB

參考資料
Reference

GLCB Series

GLCB5

GLCB8

三菱伺服馬達參考資料

Mitsubishi Servo Motor Information

馬達型號 Servo Motor	無煞車 No Brake	HG-AK0336	HG-KR053	HG-KR13	HG-KR23	HG-KR43	HG-KR73	HG-SR102	HG-SR152	
	有煞車 With Brake	HG-AK0336B	HG-KR053B	HG-KR13B	HG-KR23B	HG-KR43B	HG-KR73B	HG-SR102B	HG-SR152B	
搭配驅動器型號 Motor Drives		MR-J3W-0303BN6	MR-J4-10A	MR-J4-10A	MR-J4-20A	MR-J4-40A	MR-J4-70A	MR-J4-100A	MR-J4-200A	
電源設備容量 (kVA) Power Supply Capacity		480(W)	0.3	0.3	0.5	0.9	1.3	1.7	2.5	
額定輸出 (W) Power Consumption		30	50	100	200	400	750	1000	1500	
額定轉矩 (N.m) Rated Torque		0.095	0.16	0.32	0.64	1.3	2.4	4.8	7.2	
瞬時最大轉矩 (N.m) Instantaneous Maximum Torque		0.286	0.56	1.1	2.2	4.5	8.4	14.3	21.5	
額定電流 (Arms) Rated Current		2.2	0.9	0.8	1.3	2.6	4.8	5.6	9.4	
最大電流 (Arms) Maximum Current		6.6	3.2	2.5	4.6	9.1	17	17	29	
額定轉速 (r/min) Rated Speed		3000						2000		
最高轉速 (r/min) Maximum Speed		6000						3000		
慣量力矩 (X10 ⁻⁴ kg.m ²) load Inertia	無煞車 No Brake	0.0061	0.045	0.0777	0.221	0.371	1.26	11.6	16	
	有煞車 With Brake	0.0074	0.0472	0.0837	0.243	0.393	1.37	13.8	18.2	
建議負載慣量與力矩比 Ratio		30 倍以下 Under 30 Multiple	17 倍以下 Under 17 Multiple		26 倍以下 Under 26 Multiple	25 倍以下 Under 25 Multiple	17 倍以下 Under 17 Multiple			
速度、位置檢出器 Controller	型式 Type	絕對值，增量型共用之編碼器 (Incremental, Share With Controller)								
		18bit	22bit							
	一回轉分解能 Encoder Resolutiss Of Servo Motor	262144 p/rev	4194304 p/rev							
保護構造 (全閉自冷) Structure (Natural-cooling,Open)		保護等級 IP55 IP Rating:IP55	保護等級 IP66 IP Rating:IP66				保護等級 IP67 IP Rating:IP67			
使用環境 Environmental Conditions	周圍溫度 Ambient Temperature	0°C ~40°C (不可結冰)，保存 -15°C ~70°C (避免凍結) 0°C ~40°C Non-freezing, -15°C ~70°C Non-freezing								
	周圍溼度 Ambient Humidity	10%RH~80%RH(不可結露)，保存 10%RH~90%RH(避免結露) 10%RH~80%RH Non-freezing, 10%RH~90%RH Non-condensing								
	安裝場所 Ambience	室內 (避免陽光直射)、腐蝕性氣體、引火性氣體、油霧、塵埃避免 Indoors(no direct sunlight), Free From Corrosive Gas, Flammable Gas, Oil Mist, Dust, And Dirt.								
	安裝高度 Altitude	海拔 1000m 以下 Max. 1000 m Above Sea Level	海拔 2000m 以下 Max. 2000 m Above Sea Level							
	耐振性 Vibration	X:49m/s ² Y:49m/s ²						X:24.5m/s ² Y:24.5m/s ²		
重量 (kg)Weight	無煞車 No Brake	0.16	0.34	0.54	0.91	1.4	2.8	6.2	7.3	
	有煞車 With Brake	0.26	0.54	0.74	1.3	1.8	3.8	8.2	9.3	

型號 Model	30W	L
HG-AK0336	無煞車 No Brake	68
HG-AK0336B	有煞車 With Brake	100

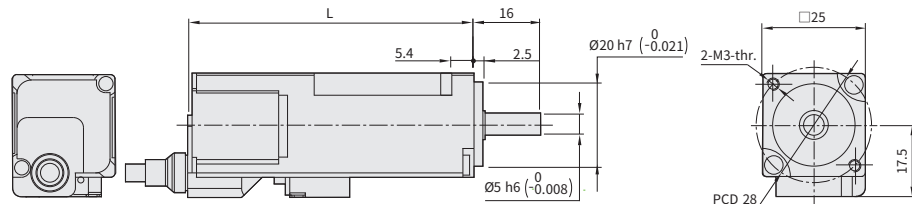

30W

型號 Model	50W	L
HG-KR053	無煞車 No Brake	66.4
HG-KR053B	有煞車 With Brake	107
型號 Model	100W	L
HG-KR13	無煞車 No Brake	82.4
HG-KR13B	有煞車 With Brake	123

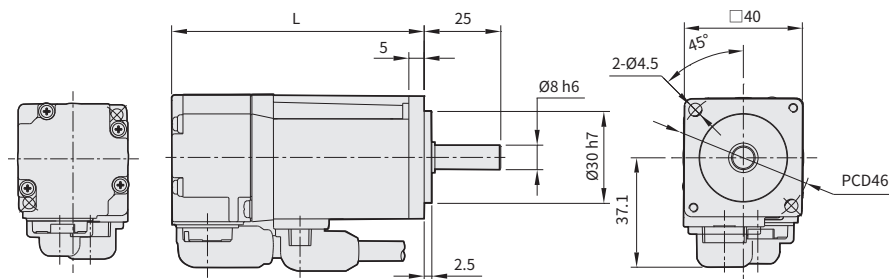

50/100W

型號 Model	200W	L
HG-KR23	無煞車 No Brake	76.6
HG-KR23B	有煞車 With Brake	113.4

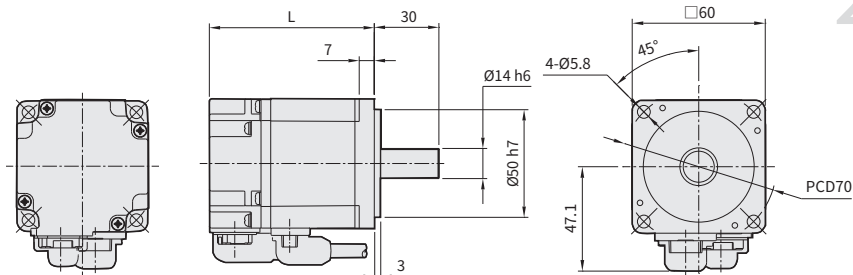

200W

型號 Model	400W	L
HG-KR43	無煞車 No Brake	98.3
HG-KR43B	有煞車 With Brake	135.1

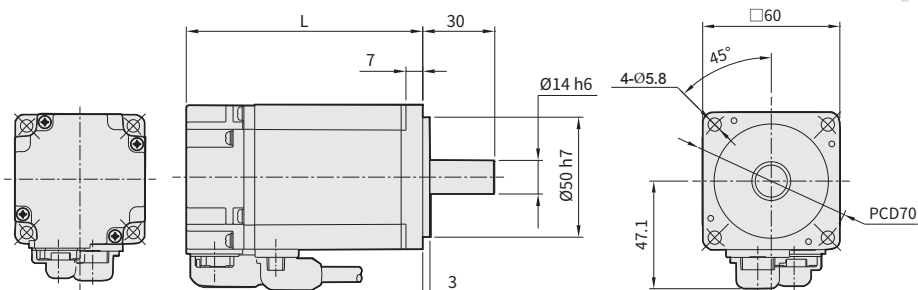

400W

型號 Model	750W	L
HG-KR73	無煞車 No Brake	112
HG-KR73B	有煞車 With Brake	152.3

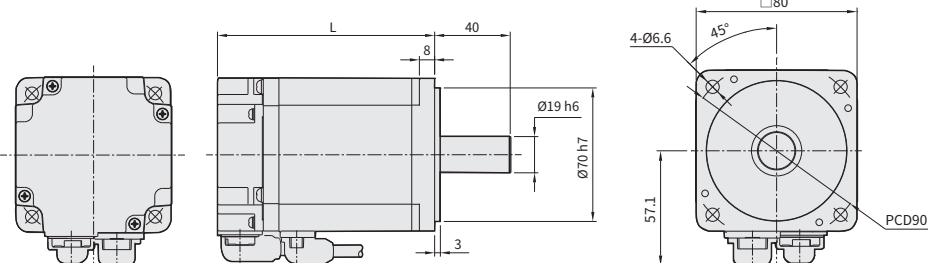

750W

型號 Model	1000W	L
HG-SR102	無煞車 No Brake	132.5
HG-SR102B	有煞車 With Brake	167

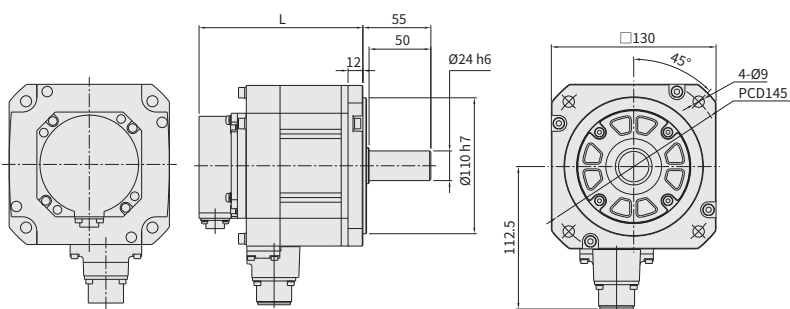

1000W

型號 Model	1500W	L
HG-SR152	無煞車 No Brake	146.5
HG-SR152B	有煞車 With Brake	181

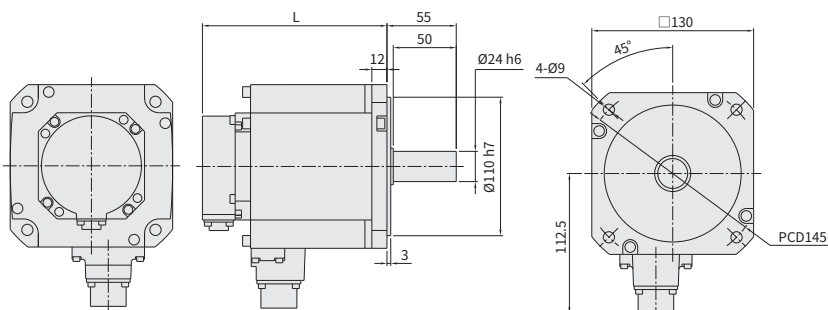

1500W

國際伺服馬達參考資料

Panasonic Servo Motor Information

馬達型號 Servo Motor	無煞車 No Brake	MSMF5AZL1U	MSMF012L1U	MHMF022L1U	MHMF042L1U	MHMF082L1U	MDMF102L1G	MDMF152L1G	
	有煞車 With Brake	MSMF5AZL1V	MSMF012L1V	MHMF022L1V	MHMF042L1V	MHMF082L1V	MDMF102L1H	MDMF152L1H	
搭配驅動器型號 Motor Drives		MADLT05SF	MADLT05SF	MADLT15SF	MBDLT25SF	MCDLT35SF	MDDL45SF	MDDL55SF	
電源設備容量 (KAV) Power Supply Capacity		0.5	0.5	0.5	0.9	1.8	2.4	2.9	
額定輸出 (W) Power Consumption		50	100	200	400	750	1000	1500	
額定轉矩 (N.m) Rated Torque		0.16	0.32	0.64	1.27	2.39	4.77	7.16	
瞬間最大轉矩 (N.m) Instantaneous Maximum Torque		0.48	0.95	2.23	4.46	8.36	14.3	21.5	
額定電流 (Arms) Rated Current		1.1	1.1	1.4	2.1	3.8	5.2	8	
最大電流 (Arms) Maximum Current		4.7	4.7	6.9	10.4	18.8	22	34	
額定轉速 (r/min) Rated Speed		3000					2000		
最高轉速 (r/min) Maximum Speed		6000					3000		
慣量力矩 (X10 ⁻⁴ kg.m ²) Load Inertia	無煞車 No Brake	0.026	0.048	0.29	0.56	1.56	6.18	9.16	
	有煞車 With Brake	0.029	0.051	0.31	0.58	1.66	7.4	10.4	
建議負載慣量與力矩比 Load Inertia Moment Ratio		30 倍以下 Under 30 Multiple				20 倍以下 Under 20 Multiple	10 倍以下 Under 10 Multiple		
速度、位置檢出器 Controller	脈波數 Pulse	絕對值，增量型共用 23bit 之編碼器 Absolute / Incremental 23-bit Encoder							
	解析度 Resolution	8388608 p/rev							
保護構造 Structure		IP65 (不包含軸心的軸承處、電纜線及接頭) Natural-cooling, Open (IP Rating: IP65)							
使用環境 Environmental Conditions	周圍溫度 Ambient Temperature	0~40 度 (不可結冰)，保存 -20~65 度 (最高溫度保證：80°C，持續 72 小時 避免凍結) 0°C ~40°C Non-freezing, Storage: -20°C to 65°C (Maximum Temperature Tolerance: 80°C for up to 72 hours, Avoid Freezing)							
	周圍溼度 Ambient Humidity	20%RH~85%RH (不可結露) 20%RH~85%RH No Condensation							
	安裝場所 Ambience	室內 (避免陽光直射)、腐蝕性氣體、引火性氣體、油霧、塵埃避免 Indoors (no direct sunlight), Free From Corrosive Gas, Flammable Gas, Oil Mist, Dust, And Dirt.							
	安裝高度 Altitude	海拔 1000m 以下 Max. 1000 m Above Sea Level							
耐振性 Vibration		運轉時：49m/s ² (5G) 以下，停止時：24.5m/s ² (2.5G) 以下 During Operation: ≤ 49 m/s ² (5G); When Stopped: ≤ 24.5 m/s ² (2.5G)							
重量 (kg) Weight	無煞車 No Brake	0.32	0.47	0.81	1.2	2.4	4.6	5.7	
	有煞車 With Brake	0.53	0.68	1.2	1.6	3.1	6.1	7.2	

型號 Model	50W	L
MSMF5AZL1U	無煞車 No Brake	72
MSMF5AZL1V	有煞車 With Brake	102
型號 Model	100W	L
MSMF012L1U	無煞車 No Brake	92
MSMF012L1V	有煞車 With Brake	122

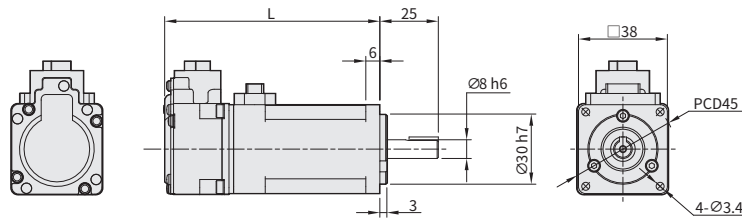

50/100W

型號 Model	200W	L
MHMF022L1U	無煞車 No Brake	71
MHMF022L1V	有煞車 With Brake	100.3

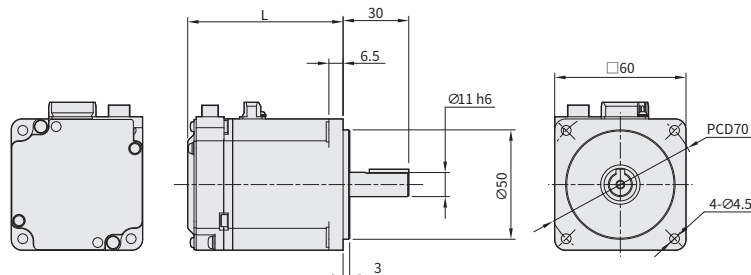

200W

型號 Model	400W	L
MHMF042L1U	無煞車 No Brake	88
MHMF042L1V	有煞車 With Brake	117.3

400W

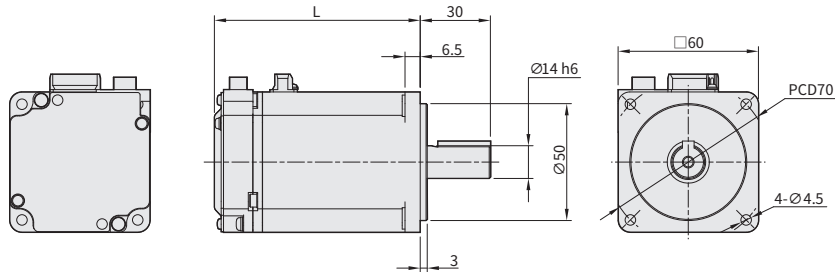

型號 Model	750W	L
MHMF082L1U	無煞車 No Brake	95.4
MHMF082L1V	有煞車 With Brake	129

750W

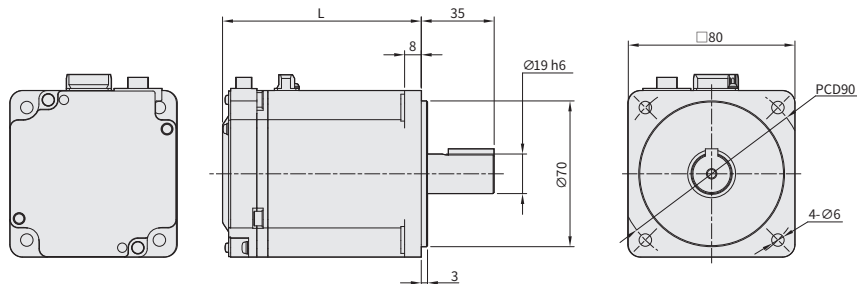

型號 Model	1000W	L
MDMF102L1G	無煞車 No Brake	122
MDMF102L1H	有煞車 With Brake	150

1000W

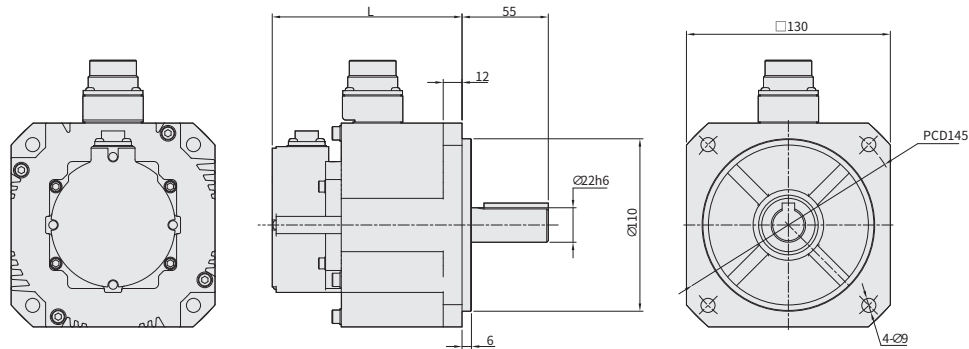

型號 Model	1500W	L	J
MDMF152L1G	無煞車 No Brake	136	(105)
MDMF152L1H	有煞車 With Brake	164	(116)

1500W

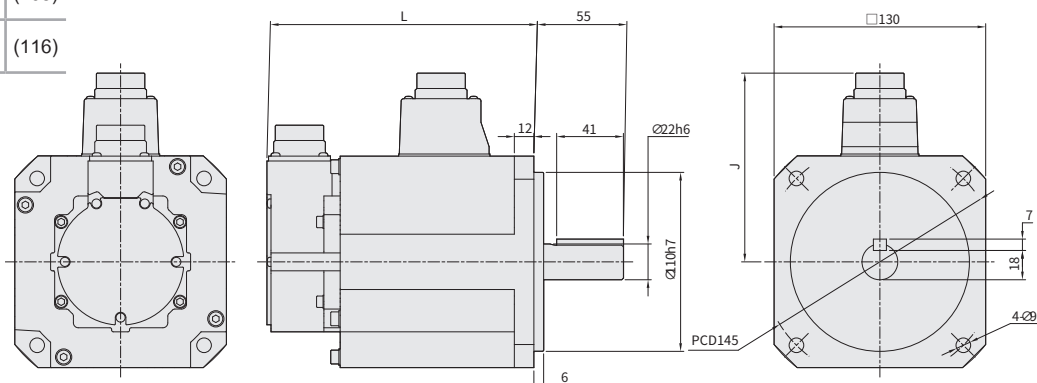

型號 Model	400W	L
ECMA-C20604ES	無煞車 No Brake	130.7
ECMA-C20604FS	有煞車 With Brake	166.8

400W

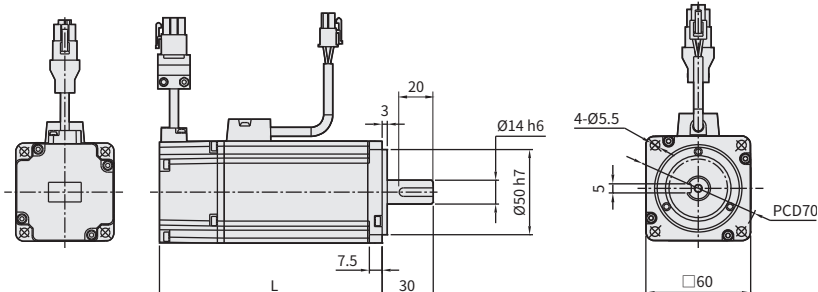

型號 Model	750W	L
ECMA-C20807ES	無煞車 No Brake	138.3
ECMA-C20807FS	有煞車 With Brake	178

750W

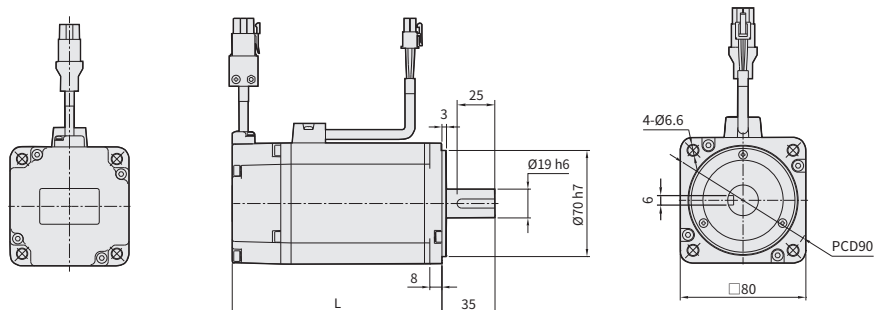

型號 Model	1000W	L
ECMA-E11310ES	無煞車 No Brake	147.5
ECMA-E11310FS	有煞車 With Brake	183.5

1000W

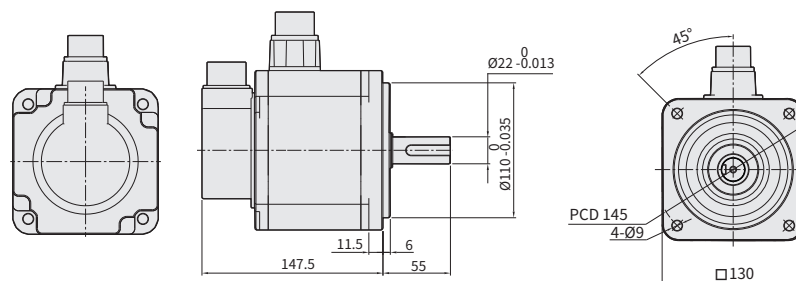

型號 Model	1500W	L
ECMA-E11315ES	無煞車 No Brake	167.5
ECMA-E11315FS	有煞車 With Brake	202

1500W

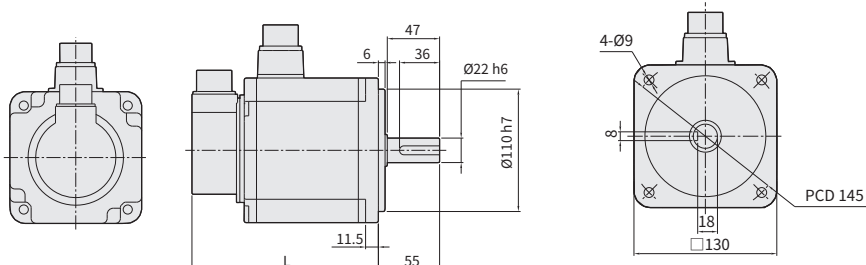

安川伺服馬達參考資料

Yaskawa Servo Motor Information

馬達型號 Servo Motor	無煞車 No Brake	SGMMV-A3A2A21	SGMJV-A5AAA21	SGMJV-01AAA21	SGMJV-02AAA21	SGMJV-04AAA21	SGMJV-08AAA21	SGMSV-10ADA21
	有煞車 With Brake	SGMMV-A3A2A2C	SGMJV-A5A3A2C	SGMJV-01AAA2C	SGMJV-02AAA2C	SGMJV-04AAA2C	SGMJV-08AAA2C	SGMSV-10ADA2C
搭配驅動器型號 Motor Drives	單相 220V	SGDV-2R1F	SGDV-R70F	SGDV-R90F	SGDV-2R1F	SGDV-2R8F	—	—
	三相 220V	SGDV-1R6A	SGDV-R70A	SGDV-R90A	SGDV-1R6A	SGDV-2R8A	SGDV-5R5A	SGDV-7R6A
額定輸出 (W) Power Consumption		30	50	100	200	400	750	1000
額定轉矩 (N.m) Rated Torque		0.0955	0.159	0.318	0.637	1.27	2.39	3.18
瞬時最大轉矩 (N.m) Instantaneous Maximum Torque		0.286	0.557	1.11	2.23	4.46	8.36	9.54
額定電流 (Arms) Rated Current		0.98	0.61	0.84	1.6	2.7	4.7	5.7
最大電流 (Arms) Maximum Current		2.9	2.1	2.9	5.8	9.3	16.9	17
額定轉速 (r/min) Rated Speed		3000						
最高轉速 (r/min) Maximum Speed		6000						
慣量力矩 (X10 ⁻⁴ kg.m ²) load Inertia	無煞車 No Brake	0.00668	0.0414	0.0665	0.259	0.442	1.57	1.74
	有煞車 With Brake	0.00804	0.0561	0.0812	0.323	0.744	1.74	1.99
建議負載慣量與力矩比 Load Inertia Moment Ratio		30 倍以下 Under 30 Multiple	20 倍以下 Under 20 Multiple		15 倍以下 Under 15 Multiple	10 倍以下 Under 10 Multiple		5 倍以下 Under 5 Multiple
速度、位置檢出器 Controller	型式 Type	絕對值 17bit 之編碼器	無煞車 No Brake	增量型 13bit 之編碼器				增量型 20 bit
			有煞車 With Brake	絕對值 20bit 之編碼器				
保護構造 Structure		全閉自冷 (保護等級 IP55) Natural-cooling, Open (IP Rating: IP55)	全閉自冷 (保護等級 IP65) Natural-cooling, Open (IP Rating: IP65)					IP67
使用環境 Environmental Conditions	周圍溫度 Ambient Temperature	0°C ~40°C, 保存 -10°C ~80°C (避免凍結) 0°C ~40°C, -10°C ~80°C Non-freezing						
	周圍溼度 Ambient Humidity	20%~80%RH 以下 (不結露) 20%~80%RH Non-condensing						
	振動等級	V15						
	耐熱等級	B						F
	絕緣耐壓	AC1500V 1 分鐘						
重量 (kg) Weight	無煞車 No Brake	0.21	0.3	0.4	0.9	1.3	2.7	4.1
	有煞車 With Brake	0.31	0.6	0.7	1.5	1.9	3.6	5.5

型號 Model	30W	L
SGMMV-A3A2A21	無煞車 No Brake	74
SGMMV-A3A2A2C	有煞車 With Brake	102.5

30W

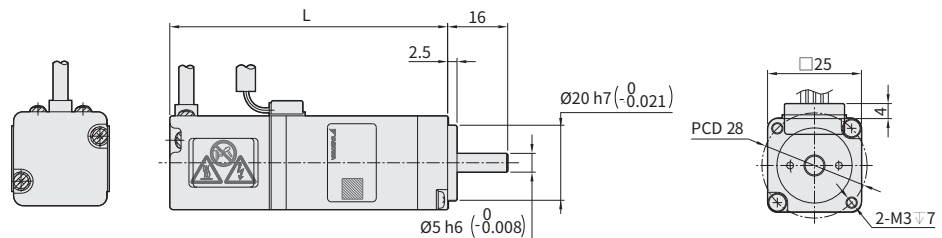

型號 Model	50W	L
SGMJV-A5AAA21	無煞車 No Brake	69
SGMJV-A5A3A2C	有煞車 With Brake	114
型號 Model	100W	L
SGMJV-01AAA21	無煞車 No Brake	82.5
SGMJV-01AAA2C	有煞車 With Brake	127.5

50/100W

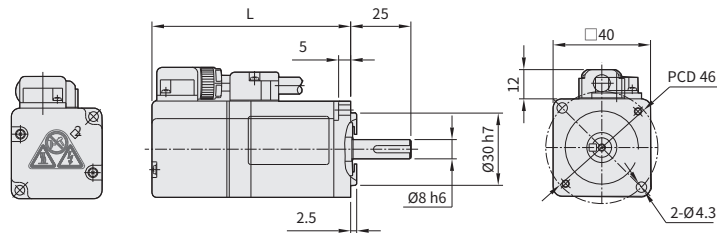

型號 Model	200W	L
SGMJV-02AAA21	無煞車 No Brake	80
SGMJV-02AAA2C	有煞車 With Brake	120

200W

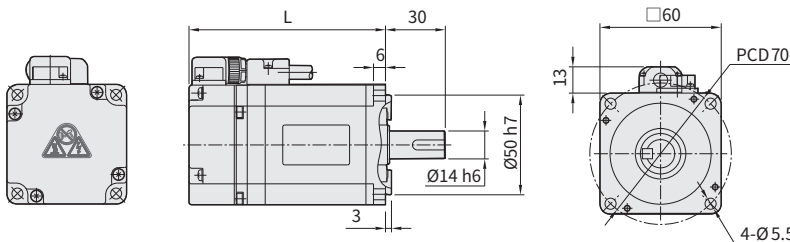

型號 Model	400W	L
SGMJV-04AAA21	無煞車 No Brake	98.5
SGMJV-04AAA2C	有煞車 With Brake	138.5

400W

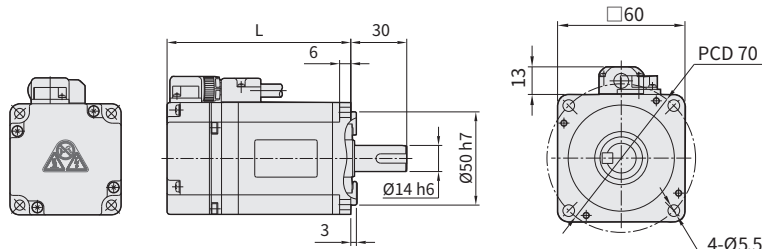

型號 Model	750W	L
SGMJV-08AAA21	無煞車 No Brake	115
SGMJV-08AAA2C	有煞車 With Brake	160

750W

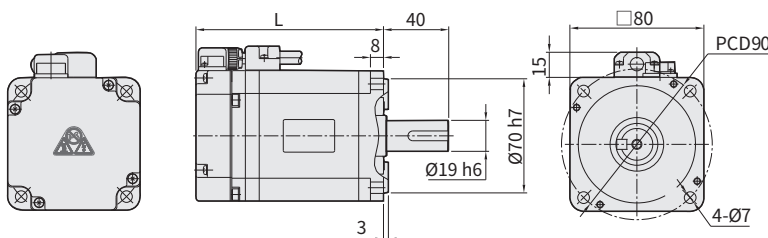

型號 Model	1000W	L
SGMSV-10ADA21	無煞車 No Brake	147
SGMSV-10ADA2C	有煞車 With Brake	188

1000W

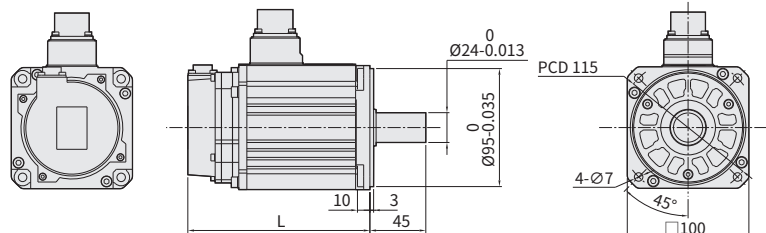

選配參考資料 Options

指定馬達出線方向

Selectable Motor Cable Leading Direction

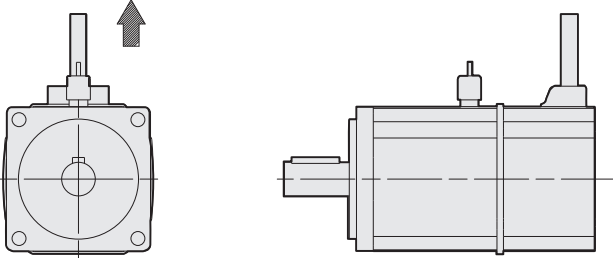
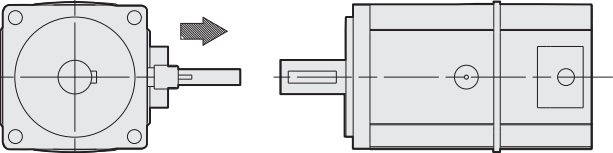
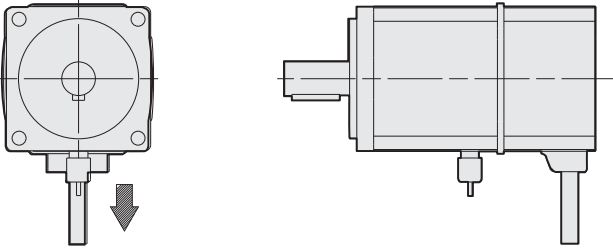
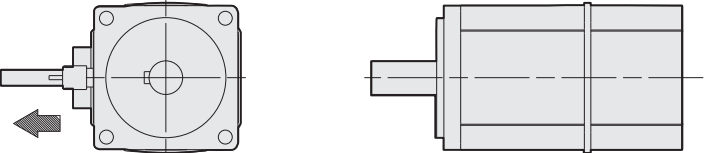
代號 Code	說明 Instructions	示意圖 Diagram
MW	<p>出線朝上 Motor cable leading direction upper side</p>	
MR	<p>出線朝右 Motor cable leading direction Right side</p>	
MM	<p>出線朝下 Motor cable leading direction Bottom side</p>	
ML	<p>出線朝左 Motor cable leading direction Left side</p>	

※ 出線方向定義方式 1. 滑台水平放置 2. 面向馬達出力軸，判斷上、下、左、右

※ Definition method of the outlet direction 1. The slide table is placed horizontally 2. Face the motor output shaft, judge up, down, left and right

指定馬達出線方向

Selectable Motor Cable Leading Direction

螺桿滑台 Ball Screw type	馬達位置對應出線方向 Motor position corresponds to power cable direction															
	BC				BL				BR				BM			
適用系列 Applicable specs	MW	MR	MM	ML	MW	MR	MM	ML	MW	MR	MM	ML	MW	MR	MM	ML
GLTH/GLTHD GLTHM GLCH/GLCHD	○	○	○	○	○	○	○	×	○	×	○	○	×	○	○	○

皮帶滑台 Belt type	馬達位置對應出線方向 Motor position corresponds to power cable direction							
	BW				BM			
適用系列 Applicable specs	MW	MR	MM	ML	MW	MR	MM	ML
GLTB GLCB	○	○	○	○	○	○	○	○

* 未指定出線方向時，以型錄圖示為主 *When the lead direction is not specified, follow the catalog diagram

應用例
Application一般 / 螺桿仕様
GTH / GTY / ETH / Y一般 / 皮帶仕様
ECB / M無塵 / 螺桿仕様
GCH / ECH無塵 / 皮帶仕様
ECB直交連結
XYGT / XTH / XYTB參考資料
Reference

選配參考資料 Options

指定馬達出線方向

Selectable Motor Cable Leading Direction

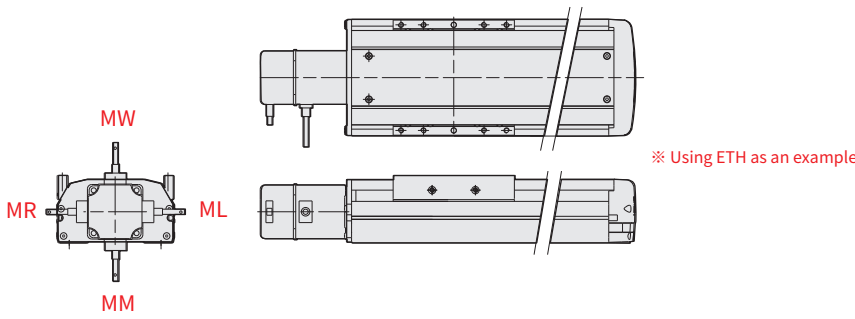
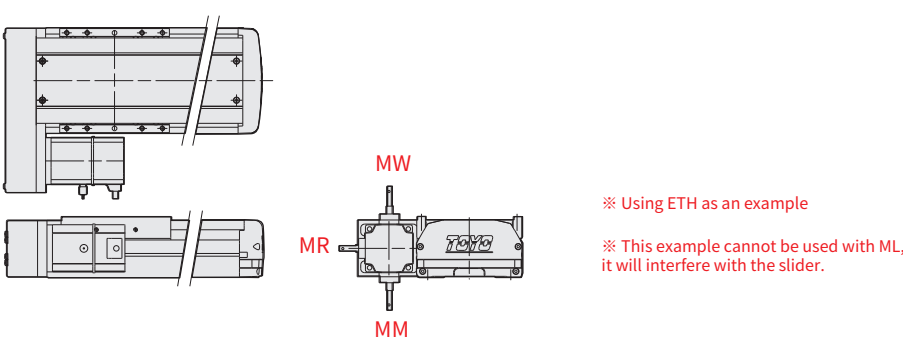
適用規格 Applicable specs	依不同規格提供範例圖示 Provide motor cable leading direction example according to different specifications
<p>GLTH 系列 GLCH 系列 GLTH series GLCH series</p>	 <p>※ Using ETH as an example</p>
<p>GLTB 系列 GLCB 系列 GLTB series GLCB series</p>	 <p>※ Using ETB6 as an example</p> <p>※ This example cannot be used with ML, it will interfere with the slider.</p>

馬達傳動配件追加鍵槽

Additional Keyway for Motor Transmission Accessories

代號 Code		說明 Instructions
CMK		馬達傳動配件追加鍵槽 (單邊 - 限定馬達側) Additional keyway for motor transmission accessories (only one side - limited to the motor side)
適用規格 Applicable specs	馬達方向 Motor position	單邊追加鍵槽示意圖 Schematic diagram of additional keyway on one side
GLTH 系列 GLCH 系列 GLTH series GLCH series	BC M	<p>Additional keyway at the motor end</p> <p>Dimensions of keyway coupling →</p> <p>Motor end (keyway type)</p> <p>Screw end (clamp type)</p> <p>※ Using GTH as an example</p>
	BL BR BM	<p>Screw end (clamp type)</p> <p>Dimensions of keyway pulley ←</p> <p>Motor end (keyway type)</p> <p>Additional keyway at the motor end</p> <p>※ Using GTH as an example</p>
GLTB 系列 GLCB 系列 GLTB series GLCB series	BW BM	<p>Additional keyway at the motor end</p> <p>Motor end (keyway type)</p> <p>Screw end (clamp type)</p> <p>※ Using GLTB5 as an example</p>

應用例
Application

一般 / 螺絲仕様
GTH / GTY / EIH / Y

一般 / 皮帶仕様
ECB / M

無塵 / 螺絲仕様
GCH / ECH

無塵 / 皮帶仕様
ECB

直交連結
XYGT / XTH / XTB

參考資料
Reference

選配參考資料 Options

馬達傳動配件追加鍵槽

Additional Keyway for Motor Transmission Accessories

代號 Code		說明 Instructions
SKY		馬達端 & 螺桿端追加鍵槽 出貨附鍵槽式零件 Additional keyway at motor end & screw end Shipment with keyway parts
SKN		馬達端 & 螺桿端追加鍵槽 出貨無鍵槽式零件 (由客戶自行購買安裝) Additional keyway at the motor end & screw end Shipment without keyway parts (purchased and installed by the customer)
適用規格 Applicable specs	馬達方向 Motor position	雙邊追加鍵槽示意圖 Schematic diagram of additional keyway on both sides
GLTH 系列 GLCH 系列 GLTH series GLCH series	BC M	<p>Additional keyway at the motor end</p> <p>Additional keyway at screw end</p> <p>Dimensions of keyway coupling →</p> <p>Motor end (keyway type)</p> <p>Screw end (Keyway type)</p> <p>※ Using GTH as an example</p>
	BL BR BM	<p>Additional keyway at screw end</p> <p>Additional keyway at the motor end</p> <p>← Dimensions of keyway pulley</p> <p>Screw end (Keyway type)</p> <p>Motor end (keyway type)</p> <p>※ Using GTH as an example</p>

各規格鍵槽對應尺寸匯整

Dimensions corresponding to the keyway of each specification

內嵌式螺桿滑台 / 電缸 Built-in linear Guide ball screw actuator/electric cylinder		螺桿型滑台 / 電缸 Ball Screw actuator / servo electric cylinder		馬達瓦數 Motor wattage	馬達軸心 Ø Motor Shaft (mm) (d1)	鍵槽寬度 Keyway Width (mm) (W1)	螺桿加工端 Ø Ball screw processing end (mm) (d2)	鍵槽尺寸 Keyway size (mm) (W2)
一般環境 General environment	無塵環境 Clean room environment	一般環境 General environment	無塵環境 Clean room environment					
GLTH5 GLTH5M GLTH5D GLCH5 GLCH5D	—	—	—	100W	8	3	7	2
GLTH8 GLTH8M GLTH8D GLCH8 GLCH8D	—	—	—	200W	11	4	10	3
				400W	14	5	10	3

各規格鍵槽對應尺寸匯整

Dimensions corresponding to the keyway of each specification

皮帶型滑台 / 電缸 Belt actuator / servo electric cylinder		馬達瓦數 Motor wattage	馬達軸心 Ø Motor Shaft (mm) (d1)	鍵槽寬度 Keyway Width (mm) (W1)	螺桿加工端 Ø Ball screw processing end (mm) (d2)	鍵槽尺寸 Keyway size (mm) (W2)
一般環境 General environment	無塵環境 Clean room environment					
GLTB5 GLCB5	—	100W	8	3	—	—
GLTB8 GLCB8	—	400W	14	5	—	—

* 若不符合以上定義時，需另外特注對應。 * If it does not meet the above definition, a corresponding special order is required.

* 當馬達軸心為平面（非鍵槽）時，不適用於此代號，例如三菱 100W。 * This code is not applicable when the motor shaft is flat (non-keyway), such as Mitsubishi 100W.

TOYO GROUP GLOBAL SERVICE



LINE



facebook



Instagram



YouTube



LinkedIn



twitter



WeChat



KAKAO

- 東佑達自動化科技股份有限公司
TOYO AUTOMATION CO., LTD.
台南市安南區新吉三路55號
No. 55, Xinji 3rd Rd., Annan Dist., Tainan City 709, Taiwan.
Tel:+886-6-2021347 Fax:+886-6-2025974
- 東佑達奈米系統股份有限公司
TOYO NANO SYSTEM CORPORATION.
新竹縣湖口鄉八德路一段67號
No. 67, Sec. 1, Bade Rd. Hukou Township, Hsinchu County 303117, Taiwan.
Tel:+886-3-5696060 Fax: +886-3-5696161
- 東佑達機器人(蘇州)有限公司
TOYO ROBOT (SHUZHOU) CO., LTD.
江蘇省昆山市張浦鎮振新東路586號(浩盛工業園C12-2)
No 586, Zhenxin East Road, Zhangpu Town, Kunshan City, Jiangsu Province, China.
Tel:+86-512-86890880 Fax:+86-512-86890881
- 東佑達自動化科技(深圳)有限公司
TOYO AUTOMATION (SHENZHEN) CO., LTD.
深圳市寶安區龍華大浪華榮路明君商務中心1208室
1208 Mingjun Business Center Huarong Road, Baoan District, Shenzhen City, China.
Tel:+86-755-81713415 Fax:+86-755-81713435
- TOYO ROBOTICS AMERICAS
Silicon Valley, CA, US
Email : ta1@toyorobot.com
- TOYO JAPAN 株式会社
埼玉県さいたま市大宮区桜木町1 - 266 - 3シンワKIビル413号室, Japan
413 Shinwa KI Building, 3-266, Sakuragicho 1 chome, Omiya-ku Saitama-shi, Saitama 330-0854 Japan
TEL:+81-48-658-8930
- TOYOROBOTICS KOREA CO.LTD.
경기도 안산시 단원구 엠티브이12로 21번길 30
30, Emtibeui 12-Ro, 21 Beon-Gil, Danwon-Gu, Ansan-Si, Gyeonggi-Do, Republic Of Korea
Tel:+82-02-6941-1681
- TOYO ROBOTICS PRIVATE LIMITED INDIA
Office No-15A, 4th Floor, A-Building City Vista, Kharadi, Pune - 411014, MH, India.
TEL:+919226535061
Email : sales@toyorobotics.co
- TOYO VIETNAM (SALES OFFICE)
Thanh Xuan district, Hanoi city, Viet Nam
TEL:+84 986 358 863
Email : vietnamtoyo_1@toyorobot.com
- TOYO ROBOT (THAILAND) CO., LTD.
118/27 Moo 18 Klong Nueng Klong Luang Pathumthani 12120 Thailand.
E-mail : stanley@toyorobot.com



※本型錄內容會有因產品改良而有變更的可能性・恕不另行通知・

※本型錄產品已投保1500萬台幣產品責任險・

Copyright © TOYO AUTOMATION CO.,LTD 版權所有・翻印必究! 2025.02

Official Website



www.toyorobot.com